

Apollo 17 ALSEP Work Tapes Lunar Ejecta And Meteorites Experiment Raw Cleaned ASCII Data Collection (1976-061 to 1976-200)

Introduction

The astronauts on the Apollo missions deployed a set of scientific instruments that were collectively known as the Apollo Lunar Surface Experiments Package (ALSEP) at each of the Apollo 12, 14, 15, 16, and 17 landing sites [1]. The ALSEP instruments operated from the time of deployment to September 1977 at each site [2]. This collection from the Apollo 17 site consists of ASCII tabular files of raw, cleaned (corrected) data from the Lunar Ejecta And Meteorites Experiment (LEAM) for the period of 1 March 1976 through 18 July 1976. The data span the last 140 days of LEAM operation. These scientific, housekeeping, and command verification data are ASCII transformations of raw binary LEAM data, archived in NASA Space Science Data Coordinated Archive (NSSDCA) data set PSSB-01475, that were extracted from NSSDCA data set PSPG-00739 [3a] which contains ALSEP normal-bit-rate Work Tape files of raw binary data transmitted from the Moon.

Required Reading

The user should read several publications before using this collection.

Required: [3a] provides a description of the contents of the source ALSEP Work Tape files. Relevant sections in [3b] are 6.11 and Appendix E including pages E-22 through E-24 that provide a brief description of the LEAM measurements. Supplementary write-ups, provided as secondary products in the Document collection, give more detailed explanations of the LEAM film ID numbering convention and the measurements for time-of-flight and the film and microphone pulse height analyzers. [6] provides detailed engineering and operations information about the Apollo 17 ALSEP station (also known as Array E and Array 5) and the LEAM experiment. The most relevant chapters in [6] are 6 - ALSEP telemetry subsystem, and 8 - LEAM operations, modes and measurements.

Strongly Recommended: [2] provides a very detailed operational history of each individual ALSEP experiment, including operational status, anomalies, and failures by date. [9] describes the LEAM experiment and reports initial results.

Additional detailed engineering and operations information on the Apollo 17 ALSEP station and the LEAM are provided in [7]. For a brief description of a specific Apollo scientific experiment together with its operational history and its data content, formats, and availability during the Apollo era, see [8]. [4] and [5] provide background on the effort to recover and restore ALSEP raw instrument data.

Overview of Data Products

This collection contains three types of data products, where each type consists of a file of time-ordered, ASCII data in fixed-width tabular format (.tab) and a detached PDS label (.xml) that defines the format and contents of the data file:

- Raw Science Data: 287 products of raw LEAM scientific measurements with filenames a17_lem_1976DDDtHH_MM_wtTT_FF.tab/.xml, where DDD is the earth-received time day of year, HH is the hour, MM is the minute, TT is the Work Tape number and FF

identifies the specific data file within the given Work Tape; all 287 products have the same tabular format,

- Raw Housekeeping: One product of raw analog LEAM Housekeeping (Engineering) data with filename a17_lear_1976_11_wt_hk.tab/.xml, and
- Command Verification: One product containing a log of LEAM Command Verifications with filename a17_lear_1976_11_wt_cv.tab/.xml.

Raw Science Data Products

These products contain raw, unreduced, magnitude, location, and time measurements of ionized plasma resulting from meteorite and ejecta impacts on the Up, East, and West film and grid assemblies of the LEAM experiment [6, 7, 9]. These measurements were converted within the LEAM experiment to digital data numbers (DN) and stored in the designated ALSEP data words [6] at the proper demand time in serial form for relay to Earth. ALSEP Main Frame Words are also known as ALSEP data words or simply as ALSEP words

Each daily ASCII file (a17_lear_1976DDDdHH_MM_wtTT_FF.tab) consists of one header record followed by two tables in this order:

1. Header: A single record that identifies the columns (fields) in the TimeOffsets and RawData tables. Each scientific data column is identified by the ALSEP Measurement Number (also known as Measurement symbol), such as DJ-1, as listed in Appendix B.
2. TimeOffsets Table: A one-record fixed-width ASCII table that provides a derived sampling-rate-adjusted delay time as an offset in milliseconds for computing the time for each data measurement in each RawData Table record.

The sampling-rate-adjusted delay times (offsets) were calculated specifically for this restoration using an ALSEP frame duration time of 603.77 milliseconds per frame, or 9.4339 milliseconds per ALSEP data word.

3. RawData Table: A multi-record fixed-width ASCII table where each record contains the raw scientific measurements for one LEAM cycle. Each record begins with the earth-received time in UTC for the set of data in that record followed by 31 raw scientific measurements identified by their LEAM Measurement Number, DJ-n: 11 measurements from the front and rear of the Up Dual Sensor Assembly (DJ-1 to DJ-11); 11 measurements from the front and rear of the East Dual Sensor Assembly (DJ-12 to DJ-22); 7 measurements from the West Single Sensor Assembly (DJ-23 to DJ-27, DJ-30, and DJ-31); and 2 engineering measurements (DJ-28 and DJ-29). The records are ordered by earth-received time. A cross reference of each DJ Measurement Number to a specific data point (“Measurement Name”) is provided on page E-24 of [3b] and in Table 6-X of [6], shown in Appendix B below.

Measurements DJ-1, DJ-4, DJ-12, DJ-15, and DJ-23 specify the film grid numbers from 0 to 15, also known as identifiers or IDs, for each of the LEAM up, east, and west sensors, respectively. For a detailed explanation and illustrations of this numbering convention, see the supplementary write-up titled “Apollo 17 Lunar Ejecta and Meteorites Experiment - Film ID numbering convention used in the LEAM data”, a17_lear_film_id_convention_descr.pdf, which is included as a secondary product in the Document collection.

The Document collection also includes, as secondary products, supplementary write-ups that explain Time-Of-Flight (elapsed time) sensor values (DJ-11 and DJ-22), the film Pulse Height Analyzer levels (DJ-2, DJ-5, DJ-13, DJ-16, and DJ-25), and the microphone Pulse Height Analyzer levels (DJ-8, DJ-19, and DJ-30). See

a17_learm_time_of_flight_sensor_values.pdf, a17_learm_film_phn_levels.pdf, and a17_learm_microphone_phn_levels.pdf.

The measurements from the various film and microphone Accumulators (DJ-3, DJ-6, DJ-9, DJ-14, DJ-17, DJ-20, DJ-26, and DJ-31) are modulo 8 values that cycle from 0 through 7 and then back to 0, changing by 1 each time an event is recorded. For example, DJ-3 changes by 1 each time an event is recorded on the front film of the Up Dual Sensor Assembly.

These raw measurements are provided in this table as decimal integers with units of data number (DN) which is another name for digital unit (DU), the term typically used in ALSEP documentation. DN or DU, also known as digital count or instrument count, is the unit of measure for the raw digital number output by the experiment analog-to-digital converter. The label specifies units of DN which is the PDS convention. The user should refer to the required reading sections in [3b] and [6] to understand the raw measurement values. These publications indicate the value for a raw LEAM measurement comprises 6-, 4-, 3-, 2-, or 1-bit positive integers. Therefore in the RawData table, DJ-11 and DJ-22 are 6-bit integers ranging from 0 to 63 DN; DJ-1, DJ-4, DJ-7, DJ-10, DJ-12, DJ-15, DJ-18, and DJ-21 are 4-bit integers ranging from 0 to 15 DN; DJ-2, DJ-3, DJ-5, DJ-6, DJ-8, DJ-9, DJ-13, DJ-14, DJ-16, DJ-17, DJ-19, DJ-20, DJ-25, DJ-26, DJ-30, and DJ-31 are 3-bit integers ranging from 0 to 7 DN; DJ-23, DJ-24, and DJ-27 are 2-bit integers ranging from 0 to 3 DN; and DJ-28 and DJ-28 are 1-bit integers ranging from 0 to 1 DN.

The PDS data label defines for layout of this table and describes the contents of each column. Additional explanation of the contents is provided here.

- Records are ordered by the earth-received time in the first column. The format is YYYY-DDDTHH:MM:SS.sss, where DDD is day of year.

This earth-received time is the time when the first word of the ALSEP frame containing the DJ-1 measurement was received on earth, referenced to the standard time signal received at a Manned Space Flight Network station. When the operators had a problem reading the time signal, they substituted it with a computer-generated time, which they called the “software clock”.

The earth-received time is followed by a quality flag which is set to an asterisk “*” if the time value is from the software clock; if there is a suspected transmission, data synchronization or tape read error in the value; or if the time value is clearly outside the expected range for this restoration effort. A negative sign “-” indicates this value is the earth-received time, and the value does not have a suspected read or transmission error or that it is unknown if there was an error and therefore could still contain an error.

- A data value of integer -9 (negative nine) indicates a missing value.
- Each DJ data value is followed by a quality flag which is set to an asterisk “*” if that data value has a suspected transmission, data synchronization or tape read error. A negative sign “-” indicates this data measurement does not have a suspected read or transmission error or that it is unknown if there was an error and therefore could still contain an error.
- To compute the time for a specific data measurement, add the milliseconds time offset, which is found in the single-record table TimeOffsets for the data measurement column of interest, to the time stamp (earth-received time) in the first column of the RawData record containing the data measurement of interest.
- The earth-received times can be reformatted from YYYY-DDDTHH:MM:SS.sss to decimal day by extracting the day of year (DDD), hour (HH), minute (MM), and seconds

(SS.sss) strings from the timestamp, converting them to floating point, then performing this calculation:

$$\text{decimal day} = \text{DDD} + (\text{HH} * 3600. + \text{MM} * 60. + \text{SS.sss}) / 86400.0$$

where 86400.0 is the number of seconds in a day. Pay careful attention to the number of digits the computer carries. For example, to preserve the millisecond-resolution of the timestamps 11 decimal digits (or 35 binary digits) need be kept, and therefore the variables DDD, HH, MM, and SS.sss may need to be defined as double-precision floating point. Using single-precision floating-point variables to reformat the timestamps would reduce the resolution to about a second.

Raw Housekeeping Data Product

This product contains raw LEAM Housekeeping (HK) measurements, identified by Measurement Numbers AJ-n, from analog sensors that indicate the condition of the LEAM experiment. Housekeeping measurements were stored in ALSEP Word 33 [3] as Measurement Numbers AJ-1 to AJ-11 for relay to Earth.

The ASCII HK file (a17_lem_1976_11_wt_hk.tab) consists of one header record followed by two tables in this order:

1. Header: A single record that identifies the columns (fields) in the TimeOffsets and RawHK tables. Each HK data column is identified by the ALSEP Measurement Numbers such as AJ-1 as listed in Appendix C.
2. TimeOffsets Table: A one-record fixed-width ASCII table that provides a derived sampling-rate-adjusted delay time as an offset in milliseconds for computing the time for each data measurement in each RawHK Table record.

The sampling-rate-adjusted delay times (offsets) were calculated using the same ALSEP frame duration time as the Raw Science Data Products: 603.77 milliseconds per frame, or 9.4339 milliseconds per ALSEP data word.

3. RawHK Table: A multi-record fixed-width ASCII table containing raw analog LEAM Housekeeping data, where one record contains the housekeeping measurements from Word 33 of ALSEP frame numbers 83, 84, and 85. Each record begins with the reference earth-received time in UTC for the set of data in that record followed by: the frame 83 Measurement Number (1, 2, 3, 4, or 5 for AJ-1, AJ-2, AJ-3, AJ-4, or AJ-5, respectively) and its data value; the frame 84 Measurement Number (6, 7, 8, 9, or 10 for AJ-6, AJ-7, AJ-8, AJ-9, or AJ-10, respectively) and its data value; and the frame 85 data measurement (AJ-11). The records are ordered by earth-received time. A cross reference of each AJ Measurement Number to a specific data point ("Measurement Name") is provided on page E-11 of [3b] and in Appendix C. Each HK measurement AJ-1 to AJ-10 appears once every 450 ALSEP frames, about once every 4.5 minutes [7: pages 225 and 233] as described in Appendix C.

These raw measurements are provided in this table as decimal integers with units of data number (DN). The user should refer to the required reading sections in [3b] and [6] to understand the raw HK values and the operating range and nominal limits for the HK analog sensors. These publications indicate the value for a raw LEAM HK measurement comprises 8-bits, and thus the range of integer values in the RawHK table is 0 to +255 DN. Please note the nominal operating limits and operating ranges for AJ-1 to AJ-11 shown in Appendix C are in physical units such as volts or degrees Fahrenheit.

The PDS data label defines for layout of this table and describes the contents of each column and if applicable its range of values and their meanings. Additional explanation of the contents is provided here:

- Records are ordered by the earth-received time in the first column.

This earth-received time is the UTC time when the first word of the ALSEP frame number 83 was received on earth, referenced to the standard time signal received at a Manned Space Flight Network station. When the operators had a problem reading the time signal, they substituted it with a computer-generated time, which they called the “software clock”.

The earth-received time is followed by a quality flag which is set to an asterisk “*” if the time value is from the software clock; if there is a suspected transmission, data synchronization or tape read error in the value; or if the time value is clearly outside the expected range for this restoration effort. A negative sign “-” indicates this value is the earth-received time, and the value does not have a suspected read or transmission error or that it is unknown if there was an error and therefore could still contain an error.

- This restoration effort assigned Measurement Numbers AJ-n (where ‘n’ is 1 to 10) in the RawHK table because the DJ-28 analog sync parameter, which should be set to a logical one when AJ-1 and AJ-6 are input to the ALSEP data stream for the start of an AJ-1 to AJ-10 cycle, was unreliable for the time span of this data collection. A value of integer 88 indicates the Measurement Number is undetermined.
- A HK value of integer -9 (negative nine) indicates a missing value.
- Tables 6-VIII and 6-X of [6], shown in Appendix C, specify the nominal operating limits and operating ranges for the analog sensors for HK measurements AJ-1 through AJ-11. Please note these values are given in physical units, not DN.
- Each HK data value is followed by a quality flag which is set to an asterisk “*” if that data value has a suspected transmission, data synchronization or tape read error. A negative sign “-” indicates this data measurement does not have a suspected read or transmission error or that it is unknown if there was an error and therefore could still contain an error.
- To compute the start time for a specific Housekeeping measurement, add the milliseconds time offset, which is found in the single-record table TimeOffsets for the Housekeeping measurement column of interest, to the time stamp (earth-received time) in the first column of the RawHK record containing the Housekeeping measurement of interest.

Command Verification Data Product

This product provides a time-ordered log of commands specific to LEAM operations that were received by Apollo 17 ALSEP and acted upon. These Command Verifications (CV) are stored in ALSEP Word 7 as Measurement Numbers DA-5 and DA-6 for relay to Earth.

The ASCII CV file (a17_17_1976_11_wt_cv.tab) consists of one header record and one table in this order:

1. Header: A single record that identifies the columns (fields) in the CVLog table.

2. CVLog Table: A multi-record fixed-width ASCII table providing a log of time-ordered Command Verification (CV) messages for LEAM operations. CV messages consist of a command counter code (the CV value) and its Message Acceptance Pulse (MAP) bit flag that reads out a “1” when the command parity error check was successful and the command was accepted and acted upon, as explained on page E-8 of [3b]. Each record contains an earth-received time, the command counter code as an octal integer and its MAP for one CV message. The CV values for LEAM operations are listed in Appendix D of this document.

- Records are ordered by the earth-received time in the first column.

The time given here is not the command time. It is the earth-received time in UTC of the first word of the ALSEP frame in which the CV was recorded, referenced to the standard time signal received at a Manned Space Flight Network station. The command was received and acted upon sometime before the CV was recorded (+57 milliseconds after the earth-received time). When the operators had a problem reading the time signal, they substituted it with a computer-generated time, which they called “software clock”.

The earth-received time is followed by a quality flag which is set to an asterisk “*” if the time value is from the software clock; if there is a suspected transmission, data synchronization or tape read error in the value; or if the time value is clearly outside the expected range for this restoration effort. A negative sign “-” indicates this value is the earth-received time, and the value does not have a suspected read or transmission error or that it is unknown if there was an error and therefore could still contain an error.

- The command counter code and its MAP bit are followed by a quality flag which is set to an asterisk “*” if the CV and/or its MAP has a suspected read or transmission error. A negative sign “-” indicates these values do not have a suspected read or transmission error or that it is unknown if there was an error and therefore could still contain an error.

Caveats/Confidence Level

Earth-Received Time

The earth-received times in the data products are approximately 1.19 to 1.37 seconds after the time when the data were acquired on the moon. This estimate, taken from ephemerides computed by the JPL Horizons System (<https://ssd.jpl.nasa.gov/?horizons>), is the minimum and maximum one-way down-leg light-time from the center of the moon (radius 1737 km) to a Manned Space Flight Network station on Earth (Canberra or Goldstone) for the time span of the data products.

Raw Data vs. Reduced Data

This collection contains only raw, unreduced data in units of DN (digital counts). Information for transforming the raw DN to physical values is not readily available, and providing this along with calibration information and transfer function of the instrument is beyond the scope our restoration effort. Please note Tables 6-VIII and 6-X of [6], shown in Appendix C, provide design values, which may be sufficient for some analyses, and not the real calibration values.

The LEAM instrument is identical to the Cosmic Dust Detectors (CDD) on the Pioneer 8 and 9 spacecraft, and the resulting data are connected. The main calibrations for LEAM are contained in the Pioneer 8 and 9 CDD calibration notebook #1 by Dr. Otto Berg [10], the PI for all three instruments. Researchers should also consult the Pioneer 8 and 9 CDD calibration notebook #2 [10] and the LEAM calibration notebook [11], also by Dr. Berg. For example, per

communication from external reviewer Jason McLain: "Data on the pulse height analysis (PHA) versus kinetic energy (KE) such as those shown on page 11 of CDD notebook #1 [10] are needed to determine the mass of a dust impactor. Understanding the range of the PHA value (0-7) with respect to the KE distribution is very important. One major caveat is that these PHA values as well time-of-flight calibrations are temperature dependent. I believe that the notebooks contain enough of the calibration data if someone was interested that they could digitize and derive the mass and velocity of the impactors using the LEAM dataset with the CDD calibration data."

Data Quality

The goal for this restoration was to recover as much of the original data from tape as possible without overinterpreting and overcorrecting the values. Although obvious bit errors were cleaned in the source binary files, some still exist in those data and are carried over to the ASCII products in this collection. Correcting and flagging of all possible errors were beyond the scope of this restoration. However, the user needs to be aware of these errors and know that these could be corrected, if necessary, but not always. Some known data quality issues most likely caused by a transmission, data synchronization or tape read errors are:

- The quality flag that follows the earth-received time in the data products is not perfect, and there are cases where the flag is not turned on (not set to an asterisk "*") although the time stamp appears to be incorrect. The goal for this restoration was to recover as much of the original data from tape as possible without overinterpreting those values.
- Some values for earth-received time have day of year values that appear to be out of temporal order or beyond the time span of this collection, or be invalid times such a "1976-000T00:00:00.000" in a17_learm_1976190t00_11_wt05_28.tab and a17_learm_1976196t01_11_wt05_45.tab. This restoration effort attempted to flag these times. Since the data that follow are likely to be correct, the incorrect times can often be interpolated from correct times before and after.
- In the raw science data files, records may be duplicated not just at the end of one file to the next but also within a file when the ground tracking and receiving stations on Earth switched from one to the next. The HK and CV files also have many short time overlaps in the records when the data reception was switched from one ground tracking and receiving station on Earth to the next.
- The binary to ASCII translation did not skip all ALSEP frames for which the sync bit pattern in the binary source data indicated that the data are out of sync. Instead, each sync pattern was examined, and if it indicated bit shifts, i.e., if there were more than two incorrect bits in the pattern of the 22-bit string, then the data were not discarded and the data quality flags were set to an asterisk "*". The assumption is that if only one or two bits are incorrect, it is likely caused by bit errors and not bit shifts, and thus is not likely to affect the data that follow.
- The program WTLEAMKs.f which generated an initial HK file failed to correctly assign AJ-n numbers in certain cases, such as when a data gap, incorrect time or incorrect frame number was encountered. The data provider manually corrected those incorrect assignments in the final HK file, a17_learm_1976_11_wt_hk.tab, which is contained in this archive.

- Some values in the status column of the CV file may be incorrect that most likely resulted from tape read or data synchronization errors. This is often reflected in the quality flags for the data columns, which are turned on (set to an asterisk “*”) when the data are out of synchronization.

References

- [1] Davies, M. E., and T. R. Colvin, Lunar coordinates in the regions of the Apollo landers, *Journal of Geophysical Research*, Volume 105, Issue E8, pages 20,227-20,280, 2000. (doi:10.1029/1999JE001165)
- [2] Bates, J. R., et al., ALSEP Termination Report, NASA Reference Publication 1036, April 1979. (<https://ntrs.nasa.gov/archive/nasa/casi.ntrs.nasa.gov/19790014808.pdf>)
- [3a] Nakamura, Y., Catalog of Lunar Seismic Data from Apollo Passive Seismic Experiment on 8-mm Video Cassette (Exabyte) Tapes, Inst. for Geophysics, Univ. of Texas at Austin, Technical Report No. 118, June 30, 1992. (<https://nssdc.gsfc.nasa.gov/misc/documents/b53211.pdf>)
- [3b] Apollo Lunar Surface Experiments Package Archive Tape Description Document, JSC-09652, NASA Johnson Space Center, Houston, Texas, May 1975. (<https://repository.hou.usra.edu/handle/20.500.11753/42>)
- [4] Nagihara, S., Y. Nakamura, L. R. Lewis, D. R. Williams, P. T. Taylor, E. J. Grayzeck, P. Chi, and G. K. Schmidt, Search and Recovery Efforts for the ALSEP Data Tapes, 42nd Lunar and Planetary Science Conference, held March 7-11, 2011 at The Woodlands, Texas, Lunar and Planetary Institute Contribution No. 1608, Abstract 1103, 2011. (<https://www.lpi.usra.edu/meetings/lpsc2011/pdf/1103.pdf>)
- [5] Nagihara, S., Y. Nakamura, D. R. Williams, P. T. Taylor, W. S. Kiefer, M. A. Hager, and H. K. Hills, Availability Of Previously Unprocessed ALSEP Raw Instrument Data and Derivative Data and Metadata Products, 47th Lunar and Planetary Science Conference, held March 21-25, 2016 at The Woodlands, Texas, Lunar and Planetary Institute Contribution No. 1903, Abstract 1194, 2016. (<https://www.hou.usra.edu/meetings/lpsc2016/pdf/1194.pdf>)
- [6] Apollo Lunar Surface Experiments Package Systems Handbook: Apollo 17, ALSEP 5 - Array E / Document Change 1, NASA Manned Spacecraft Center, Houston, Texas, 8 August 1972, updated October 1972. (<https://repository.hou.usra.edu/handle/20.500.11753/668>)
- [7] Apollo Lunar Surface Experiments Package: Apollo 17 ALSEP (Array E) Familiarization Course Handout, NASA CR-128636, NASA Manned Spacecraft Center, Houston, Texas, 1 September 1972. (<https://repository.hou.usra.edu/handle/20.500.11753/13>)
- [8] Lauderdale, W. W., and W. F. Eichelman, Apollo Scientific Experiments Data Handbook, NASA, TM-X-58131, Houston, Texas, August 1974, updated August 1976. (<https://repository.hou.usra.edu/handle/20.500.11753/17> or <https://ntrs.nasa.gov/archive/nasa/casi.ntrs.nasa.gov/19760007062.pdf>)
- [9] Apollo 17 Preliminary Science Report, NASA SP-330, NASA, Washington, D.C., January 1973. (<https://ntrs.nasa.gov/archive/nasa/casi.ntrs.nasa.gov/19740010315.pdf>)

[10] Berg, O. E., and D. R. Williams, "Pioneer 8 and 9 Cosmic Dust Detector Calibration Notebook Bundle", NASA Planetary Data System, id: urn:nasa:pds:pioneer89cdd, 2017. Contains digital reproductions of two hand-written laboratory notebooks of calibration analyses for the Pioneer 8 and 9 Cosmic Dust Detectors by Dr. Berg.

[11] Berg, O. E., D. R. Williams, and M. Gaddy, "Apollo 17 Lunar Ejecta And Meteorites Experiment Calibration Notebook Bundle", NASA Planetary Data System, id: urn:nasa:pds:a17leamcal, 2017. Contains a digital reproductions of the hand-written laboratory notebook of calibration analyses for the Apollo 17 LEAM experiment by Dr. Berg.

Appendix A

The Apollo 17 ALSEP main frame word assignments from [6].

ALSEP word assignment for array E ALSEP 5
BASIC.

1 SYNC	2 SYNC	3 SYNC & ID	4 LSG	5 LMS	6 LSG	7 COMMAND VERIFI- CATION	8 LSG
9 N/A	10 LSG	11 N/A	12 LSG	13 N/A	14 LSG	15 N/A	16 LSG
17 LMS	18 LSG	19 LMS	20 LSG	21 LMS	22 LSG	23 HF	24 LSG
25 LSG	26 LSG	27 LSG	28 LSG	29 LSG	30 LSG	31 LEAM	32 LSG
33 HOUSE- KEEPING	34 LSG	35 LSG	36 LSG	37 LSG	38 LSG	39 LEAM	40 LSG
41 N/A	42 LSG	43 N/A	44 LSG	45 N/A	46 LSG	47 N/A	48 LSG
49 N/A	50 LSG	51 N/A	52 LSG	53 N/A	54 LSG	55 N/A	56 LSG
57 N/A	58 LSG	59 N/A	60 LSG	61 N/A	62 LSG	63 RESERVE POWER	64 LSG

Each square represents 1 10-bit word. Total matrix = 10 x 64 = 640 bits/frame
N/A = not assigned

	Number of words per main frame
Control words (sync)	3
Lunar Mass Spectrometer Experiment	4
Command verification (8 bits upon command, otherwise all zeros)	1
Lunar Surface Gravimeter Experiment	36
Heat Flow Experiment	1
Lunar Ejecta and Meteorite Experiment	2
Housekeeping	1
Reserve power	1
Words not used (zeros are sent for each empty word)	<u>15</u>
Total	64

Figure 6-1.- Main frame format.

Appendix B

A cross reference of scientific data measurements DJ-1 to DJ-31 to a specific data point (“Measurement Name”), excerpted from page 6-25 in [6].

ALSEP 5
BASIC

TABLE 6-X.- LEAM MEASUREMENTS

Scientific Measurements

The following measurements are sequenced in ALSEP Word 31 and 39 for five consecutive main frames. The sequence is repeated for eighteen times during each set of 90 main frames.

Symbol	Measurement	Location	LEAM Word	ALSEP Word	ALSEP Main Frame	Assigned Bits
DJ-1	Front Film ID	UP Dual Sensor	1	31	1, 6, 11, etc.	1-4
DJ-2	Front Film PHA (Pulse Height Analysis)					5-7
DJ-3	Front Film Accumulator					8-10
DJ-4	Rear Film ID	Assembly	2	39	1, 6, 11, etc.	1-4
DJ-5	Rear Film PHA					5-7
DJ-6	Rear Film Accumulator					8-10
DJ-7	Front Collector ID		3	31	2, 7, 12, etc.	1-4
DJ-8	Microphone PHA					5-7
DJ-9	Microphone Accumulator					8-10
DJ-10	Rear Collector ID		4	39	2, 7, 12, etc.	1-4
DJ-11	Elapsed Time					5-10
DJ-12	Front Film ID	EAST Dual Sensor	5	31	3, 8, 13, etc.	1-4
DJ-13	Front Film PHA					5-7
DJ-14	Front Film Accumulator					8-10
DJ-15	Rear Film ID	Assembly	6	39	3, 8, 13, etc.	1-4
DJ-16	Rear Film PHA					5-7
DJ-17	Rear Film Accumulator					8-10
DJ-18	Front Collector ID		7	31	4, 9, 14, etc.	1-4
DJ-19	Microphone PHA					5-7
DJ-20	Microphone Accumulator					8-10
DJ-21	Rear Collector ID		8	39	4, 9, 14, etc.	1-4
DJ-22	Elapsed Time					5-10
DJ-23	Film ID	WEST Single Sensor Assembly	9	31	5, 10, 15, etc.	1-2
DJ-24	Collector ID					3-4
DJ-25	Film PHA					5-7
DJ-26	Film Accumulator					8-10
DJ-27	Secondary Microphone Accumulator		10	39	5, 10, 15, etc.	1-2
DJ-28	Analog Data Synchronization ID Bit					3
DJ-29	Heater Status					4
DJ-30	Main Microphone PHA					5-7
DJ-31	Main Microphone Accumulator					8-10

6-25

Appendix C

Nominal operating limits and operating ranges for the analog sensors for Housekeeping measurements AJ-1 through AJ-11, excerpted from pages 6-18 and 6-26 in [6]; and supplemental information about what each parameter measures and how AJ-1 to AJ-10 are multiplexed in the ALSEP data stream, excerpted from pages 233 and 225 in [7]. The term "channel" means the ALSEP frame number.

* ALSEP 5
BASIC/PCN-1

TABLE 6-VIII.- ANALOG CHANNEL USAGE - Continued

SYMBOL	LOCATION/NAME	CHANNEL	NOMINAL OPERATING LIMITS
HEAT FLOW			
AH-1	Supply Voltage 1 (5 v)	29	4.9 to 5.1 Vdc
AH-2	Supply Voltage 2 (-5 v)	45	-5.1 to -4.9 Vdc
AH-3	Supply Voltage 3 (15 v)	55	14.7 to 15.3 Vdc
AH-4	Supply Voltage 4 (-15 v)	74	-15.3 to -14.7 Vdc
AH-6	High Conductivity Htr Pwr Status	57	Discrete
AH-7	Low Conductivity Htr Pwr Status	75	Discrete
LUNAR SURFACE GRAVIMETER			
AG-1	Tide Signal	10	
AG-2	Free Mode Oscillation Signal	23	
AG-3	Seismic Signal	39	
AG-4	Heater Box Temp	68	
AG-5	Instrument Housing Pressure	89	5 to 20 Torr
AG-6	Mass Changing Error Signal	54	
AG-7	Oscillator Amplitude	24	1.000 to 3.500 v
AG-8	Power Converter (15 v)	38	14.75 to 15.25 Vdc
AG-9	Power Converter (-15 v)	53	-15.25 to -14.75 Vdc
AG-10	Power Converter (5 v)	69	4.75 to 5.25 Vdc
LUNAR EJECTA AND METEORITES			
AJ-1	+5 Volt Supply	83	4.30 to 4.70 Vdc
AJ-2	Sensor Dust Cover Status	83	Discrete
AJ-3	Mirror Dust Cover Status	83	Discrete
AJ-4	Power Supply Monitor	83	0.50 to 0.90 Vdc
AJ-5	Bias Voltage Monitor	83	0.30 to 0.50 v
AJ-6	Up Microphone Temp	84	-10° F to 150° F
AJ-7	East Microphone Temp	84	-10° F to 150° F
AJ-8	West Microphone Temp	84	-10° F to 150° F
AJ-9	Central Electronics Temp	84	-10° F to 150° F
AJ-10	-5 Volt Supply	84	-4.7 to -4.3 Vdc
AJ-11	Survival Temp	85	-50° F to 210° F
LUNAR SEISMIC PROFILING			
AP-1	Electronics Internal Temp	25	+33° F to 138° F

P-1

6-18

*

TABLE 6-X.- LEAM MEASUREMENTS (Concluded)

Engineering Measurements

Symbol	Measurement	ALSEP Word 33 Channel	Range	
AJ-1	LEAM +5 V Supply	83-01	5.0 ± 1.0 Volts	
AJ-2	LEAM Sensor Dust Cover Status	83-02	Octal 234 - 321 000 - 013	(Squibs Not Fired) (Squibs Fired) P-1
AJ-3	LEAM Mirror Dust Cover Status	83-03	Octal 234 - 321 000 - 013	(Squibs Not Fired) (Squibs Fired)
AJ-4	LEAM Power Supply Monitor	83-04	0.7 ± 0.2 V	
AJ-5	LEAM Bias Voltage Monitor	83-05	0.4 ± 0.2 V	
AJ-6	LEAM Up Microphone Temperature	84-01	-20° F to +150° F	
AJ-7	LEAM East Microphone Temperature	84-02	-20° F to +150° F	
AJ-8	LEAM West Microphone Temperature	84-03	-20° F to +150° F	
AJ-9	LEAM Central Electronics Temperature	84-04	-20° F to +150° F	
AJ-10	LEAM -5 V Supply	84-05	-5.0 ± 1.0 Volts	P-1
AJ-11	LEAM Survival Temperature	85	-50° F to +210° F	

LEAM ANALOG DATA

ALSEP WORD 33, CHANNEL 83, MULTIPLEXED 5 TIMES IN THE FOLLOWING SEQUENCE:

- AJ-01, LEAM +5 VOLTS (MEASURED AT OUTPUT OF LEAM POWER SUPPLY)
- AJ-02, SNSR CVR STATUS (INDICATES THAT SQUIBS HAVE OR HAVE NOT FIRED)
- AJ-03, MIR CVR STATUS (INDICATES THAT SQUIBS HAVE OR HAVE NOT FIRED)
- AJ-04, POWER SUPPLY MON (BASED ON COMBINED +12 VDC +5 VDC AND -5 VDC OUTPUT)
- AJ-05, BIAS VOLTAGES MON (BASED ON COMBINED +24 VDC AND -7.5 VDC OUTPUT)

ALSEP WORD 33, CHANNEL 84, MULTIPLEXED 5 TIMES IN THE FOLLOWING SEQUENCE:

- AJ-06, UP MAIN MIC TEMP (MEASURES UP SENSOR TEMP NEAR MICROPHONE)
- AJ-07, EAST MA IN MIC TEMP (MEASURES EAST SENSOR TEMP NEAR MICROPHONE)
- AJ-08, WEST MA IN MIC TEMP (MEASURES WEST SENSOR TEMP NEAR MAIN MICROPHONE)
- AJ-09, CENT ELECT TEMP (MEASURES TEMP IN SENSOR CENTRAL ELECTRONICS)
- AJ-10, LEAM -5 VOLTS (MEASURED AT OUTPUT OF LEAM POWER SUPPLY)

ALSEP WORD 33, CHANNEL 85:

- AJ-11, LEAM ELECT TEMP (MEASURES INTERNAL STRUCTURE TEMP NEAR THERMAL PLATE; POWERED FROM ALSEP CENTRAL STATION TO READ INDEPENDENT OF LEAM ON/STANDBY/OFF STATUS)

JULY 72 3270.6.26

[7: Page 233]

LEAM ANALOG DATA MULTIPLEXER

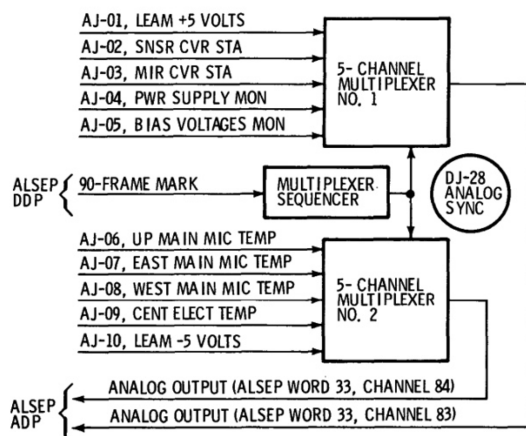

NOTES:

- DJ-28 INDICATES A LOGICAL ONE IN THE LEAM DIGITAL DATA DURING THE 90 ALSEP FRAMES WHEN AJ-01 AND AJ-06 ARE INPUT TO THE ALSEP ADP; DURING THE INTERVENING 360 ALSEP FRAMES, IT INDICATES A LOGICAL ZERO (DIGITAL ENCODING PRODUCES THE LOGICAL ONE 18 TIMES IN 90 SUCCESSIVE ALSEP FRAMES)
- MULTIPLEXER INITIALIZES TO ANY ONE OF THE FIVE STEPS BUT BOTH 1 AND 2 WILL BE AT THE SAME STEP
- EACH LEAM PARAMETER APPEARS IN THE ALSEP DOWNLINK DATA ONCE EVERY 450 ALSEP FRAMES (EVERY 4.5 MINUTES AT NORMAL DATA RATE)

JULY 72 3270.6.18

[7: Page 225]

Appendix D

Command Verification values and their actions for the LEAM instrument, excerpted from pages 5-33 and 5-35 in [6]. The LEAM commands used during the time span of this data collection are octal integers 111, 112, and 114. Supplemental explanation of these commands, excerpted from page 231 of [7].

		ALSEP 5 BASIC/PCN-1
111	LEAM CAL	EXP 2 (LEAM)
Command 111 activates the calibration control logic which injects a known signal into the experiment system. This signal is used to calibrate the overall sensor electronics and data storage system of the LEAM experiment. Two calibration levels, Mode 1 and Mode 2, shall be provided, to be selected alternately upon successive transmission of Command 111. This command is also generated automatically within ALSEP as a pair of commands 3.5 minutes apart, every 15.4 hours, unless inhibited by execution of CMD 105 (PER CMDS INH).		
112	LEAM MIR CVR	EXP 2 (LEAM)
Command 112 causes the one-time function of blowing off the LEAM thermal control mirror dust cover. This command is an irreversible function and is necessary to obtain LEAM scientific data.		
114	LEAM SEN CVR	EXP 2 (LEAM)
Command 114 causes the one-time function of blowing away the LEAM sensor dust cover. This command is an irreversible function and is necessary to obtain LEAM scientific data.		

P-1
(typo)

LEAM COMMANDS

OCTAL CMD NUMBER

111 LEAM CAL

THIS IS A TWO-STATE CMD TO SELECT ALTERNATELY, UPON SUCCESSIVE TRANSMISSION, THE TWO LEAM CALIBRATION LEVELS CALLED MODE ONE AND MODE TWO*. EACH ACTIVATION OF THE CALIBRATION CIRCUITS PRODUCES A SINGLE INPUT PULSE TO THE LEAM SENSOR BUFFER AMPLIFIERS TO CALIBRATE THE OVERALL SENSOR ELECTRONICS AND DATA STORAGE SYSTEM. THE RESPONSE OF LEAM TO CMD 111 IS DELAYED UNTIL PREVIOUSLY RECORDED DATA HAS BEEN TRANSMITTED TO ALSEP.

MODE ONE PROVIDES SIGNAL PULSES TO EACH:

- FRONT FILM AMPLIFIERS 3 AND 4 (4)
- MAIN MICROPHONE AMPLIFIERS (3)
- SECONDARY MICROPHONE AMPLIFIER (1)
- REAR FILM AND ALL COLLECTOR AMPLIFIERS (28)**

MODE TWO PROVIDES SIGNAL PULSES TO EACH:

- FRONT FILM AMPLIFIERS 1 AND 2 (4)
- MAIN MICROPHONE AMPLIFIERS (3)
- ALL REAR FILM AMPLIFIERS (10)**

112 LEAM MIR CVR GO

THIS CMD ACTIVATES THE CIRCUITS OF A REDUNDANT FIRING MECHANISM TO RELEASE THE DUST COVER WHICH PROTECTS THE LEAM THERMAL CONTROL MIRROR. AFTER COVER RELEASE, CMD 112 HAS NO FURTHER EFFECT. REMOVAL OF THE MIRROR DUST COVER IS SCHEDULED AFTER LM ASCENT. PRIOR TO REMOVAL, THE EXTENT OF LEAM OPERATION IS CONSTRAINED BY THERMAL CONTROL LIMITATIONS.

114 LEAM SEN CVR GO

THIS CMD ACTIVATES THE CIRCUITS OF A REDUNDANT FIRING MECHANISM TO RELEASE THE DUST COVERS WHICH PROTECT THE LEAM SENSORS. AFTER COVER RELEASE, CMD 114 HAS NO FURTHER EFFECT. REMOVAL OF THE SENSOR DUST COVERS ARE SCHEDULED AFTER LM ASCENT AND AFTER DETONATION OF THE LSP EXPLOSIVE PACKAGES, AND AFTER AT LEAST TWO DAYS OF BACKGROUND DATA.

117 LEAM HTR STEP

THIS IS A THREE-STATE CMD WHICH, UPON SUCCESSIVE TRANSMISSION, STEPS REPETITIVELY THROUGH THREE LEAM HEATER CONTROL MODES: ON, OFF, AND AUTOMATIC. IN THE AUTOMATIC (NORMAL) MODE, A CIRCUIT CONTROLS THE HEATER OPERATION TO MAINTAIN LEAM ABOVE A MINIMUM TEMPERATURE. THE ON AND OFF MODES BYPASS THE AUTOMATIC CONTROL CIRCUIT AND CAUSE THE HEATER TO REMAIN ON OR OFF REGARDLESS OF TEMPERATURE. THE HEATER ON/OFF STATUS IS READ OUT IN THE TM, ALONG WITH TEMPERATURE DATA. APPLICATION OF OPERATIONAL POWER TO THE LEAM CAUSES INITIALIZATION IN THE AUTOMATIC MODE.

WHEN STANDBY (SURVIVAL) POWER IS APPLIED TO THE LEAM:

- THE AUTOMATIC CIRCUIT IS ENERGIZED AND CONTROLS OPERATION OF THE 3.2-WATT HEATER; THERE IS AN ADDITIONAL 1.6-WATT CONSTANT STANDBY HEATER
- CMD 117 HAS NO EFFECT
- TEMPERATURE IS READ OUT IN THE ALSEP CENTRAL STATION TM.

NOTES:

- *THE CALIBRATION LEVEL OF MODE TWO IS HIGHER THAN MODE ONE
- **REAR FILM SIGNALS ARE DELAYED TO VERIFY ELAPSED-TIME CIRCUITRY; DELAY IS LONGER IN MODE TWO.

JULY 72 3270.6.24