

Apollo 17 Metric (Mapping) Camera

Instrument Overview

The purpose of the Apollo Metric (Mapping) Camera experiment was to obtain high-quality metric photographs with high geometric precision of the lunar surface from lunar orbit combined with time-correlated stellar photography for selenodetic/cartographic control. Specifically, the objectives of the Metric Camera photography were to provide: 1) Data for establishing a unified selenodetic reference system ; 2) Imagery suitable for photomapping at scales as large as 1:250,000 ; and 3) Imagery at approximately 20-m ground resolution suitable for synoptic interpretation of geologic relationships and surface material distribution. A laser altimeter was operated with it. The Metric Camera also provided supporting photographic data for the Scientific Instrument Module (SIM) Panoramic Camera and other Command Service Module (CSM) photographic experiments. Approximately 2350 of the 3298 Apollo 17 Metric Camera frames contain imagery of the lunar surface.

The mapping camera system was mounted in the SIM bay of the Apollo Service Module and was composed of the laser altimeter and two individual camera subsystems -- the metric (terrain mapping) camera, which performed the cartographic function, and the stellar camera. These subsystems were integrated into a single unit that had the optical axis relationship necessary to satisfy the precision mapping camera and the laser altimeter attitude (pointing) determination requirement (Figure 1).

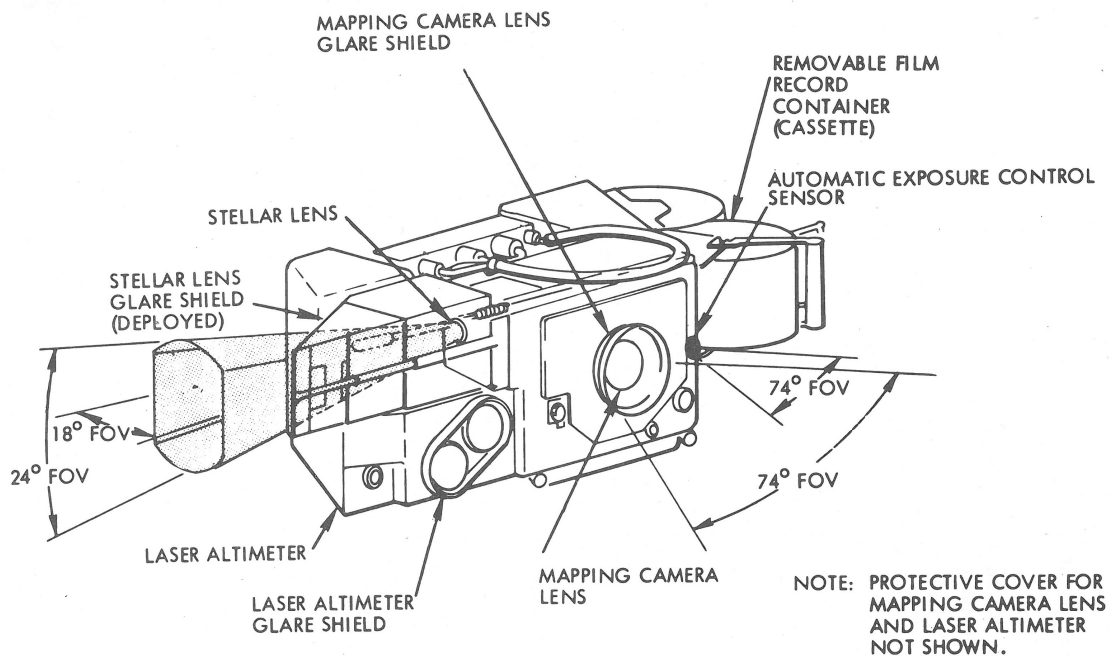

Figure 1. SIM Bay Mapping Camera System - Mapping Camera/Stellar Camera/Laser Altimeter Detail

The stellar camera photographs (using 3401 Black-and-White (B/W) Plus XX film) were taken simultaneously with the metric camera photographs and were used to determine the precise orientation of the spacecraft during metric camera and laser altimeter operation. The camera system was oriented so that the metric camera lens was pointed at the nadir, while the 35-mm stellar camera lens was pointed at the stellar field at an angle of 96 degrees from the local vertical (6 degrees above the horizon on the right side of the spacecraft) and 90 degrees from the direction of flight. This system shared a gaseous nitrogen pressure vessel assembly with the SIM panoramic camera to provide an inert and pressurized atmosphere within the cameras.

The Fairchild metric camera provided 20-m resolution photography from an orbital altitude of 110 km (~60 nautical miles). The ranges for the metric camera were (1) focal length, 76 mm (3 in.), (2) field of view, 74 deg by 74 deg, (3) image coverage (from 110 km), a 166 km by 166 km square area (about 5.5 deg by 5.5 deg), (4) image size, 114 mm by 114 mm (4.5 by 4.5 in.), and (5) film capacity, 457.2 m (1500 ft, 3500 frames) of 127 mm (5-in.) B/W film. The film type was 3400 Panatomic-X aerial film, intermediate speed, extended red sensitivity.

The camera obtained photographs at maximum aperture with varying shutter speeds (seven possible exposures between 0.004 and 0.067 seconds). The shutter consisted of a pair of continuously rotating disks and a capping blade. An exposure was made when the holes in the rotating disk came into line while the capping blade was turned to the open position. The film was held in a plane during exposure at a fixed distance from the lens node by a glass stage plate with 112 Reseau crosses inscribed on its surface. Eight fiducial marks, which defined on the film the location of the optical axis at the instant of the exposure, were exposed just outside the frame format (Figure 2).

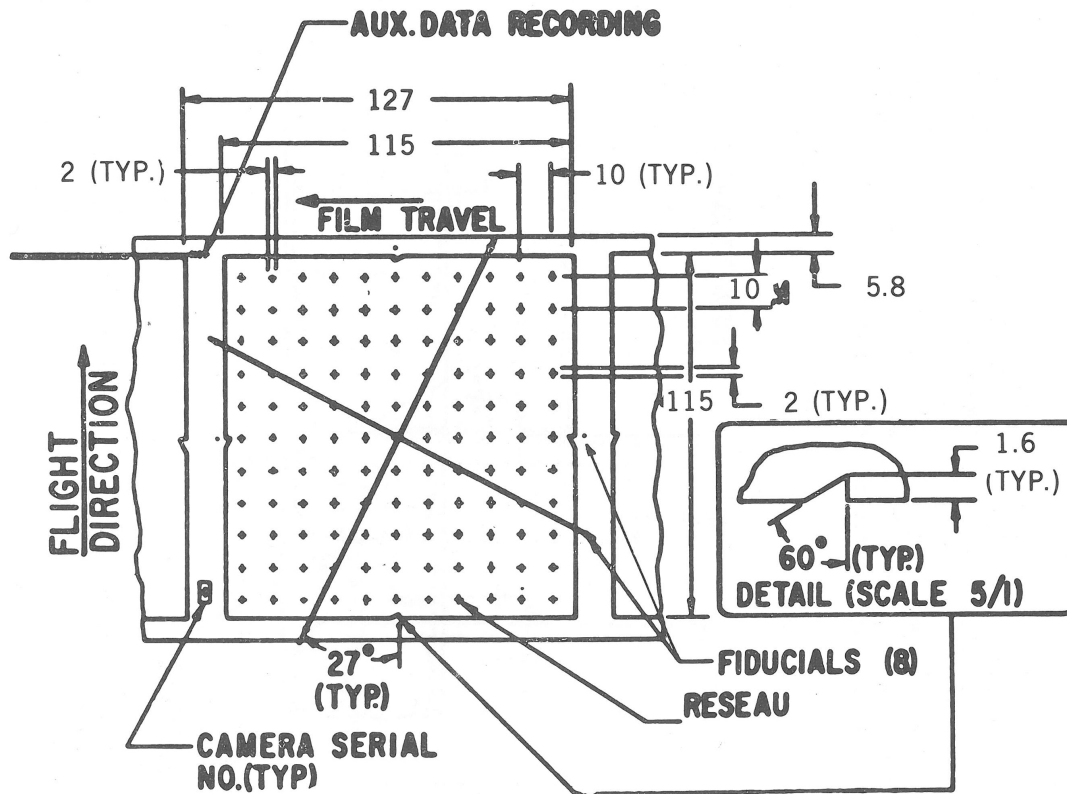

Figure 2. Mapping Camera Film Format (in millimeters)

Film forward motion was compensated by driving the plate in the direction of flight during exposure. Raw laser altimeter data were directly recorded on the film outside the image area. The camera serial number and auxiliary data of time, altitude, shutter speed, and forward motion control setting were recorded on each frame. The pictures were made with 78 percent forward overlap. By using alternate frames this may be reduced to the standard 57 percent.

The mapping camera system was mounted on the top shelf in the CSM SIM bay and was deployed on a rail-type mechanism in order to provide an unobstructed field of view for the stellar camera. This mechanism ensured that the star field was not obscured by either the lunar horizon or the SIM mold line. A cover attached to the SIM shelf protected the metric camera lens and laser altimeter optics from spacecraft contamination sources during reaction control system firings and effluent dumps. This cover provided for multiple opening and closing cycles. Camera controls in the command module allowed the crew to activate or deactivate camera heaters and camera functions, to activate or deactivate the image motion compensation switch and increment the camera velocity-to-height control signal (five incremental steps were possible before recycling), and to activate and extend or retract the camera system on its deployment rails. Exposed film from both metric and stellar cameras was accumulated in the removable film record container. The

container was recovered from the SIM bay by the Command Module Pilot by EVA during trans-Earth coast.

The Principal Investigator for the Panoramic Camera was Dr. Frederick J. Doyle of the U.S. Geological Survey.

References

Apollo 17 Preliminary Science Report, NASA SP-330, published by NASA, Washington, D.C., 1973.

Apollo Scientific Experiments Data Handbook, NASA Technical Memorandum TM-X-58131, JSC-09166, Eichelman, W. F. and Lauderdale, W. W. (Editors), NASA Johnson Space Center, Houston, Texas, published August 1974, revised April 1976.

Cameron, W. S., E. J. Mantel, and E. R. Miller, Catalog of Lunar Mission Data, NASA Technical Memorandum TM-X-72612, NSSDC 77-02, NASA Space Science Data Center (NSSDC), NASA Goddard Space Flight Center, Greenbelt, Maryland, 1977.

Cameron, W. S., F. J. Doyle, L. Levenson, and K. Michlovitz, Data User's Note - Apollo 17 Lunar Photography, NASA Technical Memorandum TM-X-72535, NSSDC 74-08, NASA Space Science Data Center (NSSDC), NASA Goddard Space Flight Center, Greenbelt, Maryland, 1974.

Source

The NASA Space Science Data Coordinated Archive (NSSDCA, formerly NSSDC) provided this description. Figures 1 and 2 were taken from Cameron et al. (1974).