



NATIONAL AERONAUTICS AND SPACE ADMINISTRATION

# APOLLO LUNAR SURFACE EXPERIMENTS PACKAGE SYSTEMS HANDBOOK

ALSEP A2 15

MARCH 24, 1971

PREPARED BY

FLIGHT CONTROL DIVISION

MANNED SPACECRAFT CENTER  
HOUSTON, TEXAS

1 INTRODUCTORY  
INFORMATION

2 GENERAL  
DESCRIPTION

3 STRUCTURAL/  
THERMAL CNTL  
SUBSYSTEM

4 ELECTRICAL  
POWER  
SUBSYSTEM

5 COMMAND  
SUBSYSTEM

6 TELEMETRY  
SUBSYSTEM

7 DTREM  
SUBSYSTEM

8 PASSIVE  
SEISMIC  
EXPERIMENT

9 LSM  
EXPERIMENT

10 SWS  
EXPERIMENT

11 SIDE/CCGE  
EXPERIMENT

12 HEAT FLOW  
EXPERIMENT

13 APOLLO LUNAR  
SURFACE DRILL

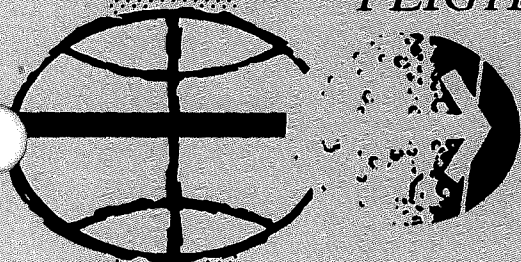

APOLLO LUNAR SURFACE EXPERIMENTS PACKAGE SYSTEMS HANDBOOK

ALSEP A2

PCN-1

PREFACE

This page change notice (PCN) is a partial revision and should be incorporated into the basic document, dated March 24, 1971, according to the page change instruction sheet which follows this page. Incorporation of PCN-1 will make this handbook current as of April 15, 1971.

This document has been prepared by the Flight Control Division, Manned Spacecraft Center, Houston, Texas. Information contained within this document represents the Apollo lunar surface experiments package (ALSEP) systems for ALSEP A2.

This document is intended for specialized use by experiment flight controllers in real-time and near-real-time operations.

Comments regarding this handbook should be directed to the Lunar/Earth Experiments Branch, Flight Control Division. Revisions will be issued as required prior to the flight date.

This document is not to be reproduced without the written approval of the Chief, Flight Control Division, Manned Spacecraft Center, Houston, Texas.

Approved by:

*Gerald D. Griffith*  
for James E. Saultz  
Chief, Lunar/Earth Experiments Branch

*Melvin F. Brooks*  
for Eugene F. Kranz  
Chief, Flight Control Division

APOLLO LUNAR SURFACE EXPERIMENTS PACKAGE SYSTEMS HANDBOOK

ALSEP A2

PCN-1

PAGE CHANGE INSTRUCTION SHEET

Update this document in accordance with the following instructions:

Remove and replace the following changed pages:

ii  
iii  
iv  
v  
vi  
8-4 (Figure 8-1)  
10-4 (Figure 10-1)  
12-4 (Figure 12-1)

Add the following new pages:

iiia  
iiib

APOLLO LUNAR SURFACE EXPERIMENTS PACKAGE SYSTEMS HANDBOOK

ALSEP A2

PREFACE

This document has been prepared by the Flight Control Division, Manned Spacecraft Center, Houston, Texas. Information contained within this document represents the Apollo lunar surface experiments package (ALSEP) systems for ALSEP A2 as of March 24, 1971.

This document is intended for specialized use by experiment flight controllers in real-time and near-real-time operations.

Comments regarding this handbook should be directed to the Lunar/Earth Experiments Branch, Flight Control Division. Revisions will be issued as required prior to the flight date.

This document is not to be reproduced without the written approval of the Chief, Flight Control Division, Manned Spacecraft Center, Houston, Texas.

Approved by:

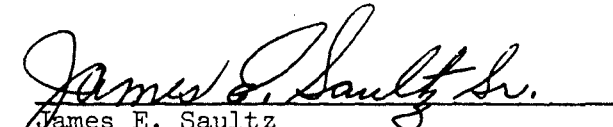
  
James E. Saultz  
Chief, Lunar/Earth Experiments Branch

  
Eugene F. Kranz  
Chief, Flight Control Division

\*

## FOREWORD

In order to assure a clear understanding of the method used for revising Flight Control Division documentation, the following standard system has been established and is applicable to this document.

The first time a particular document is published it is called the "basic" document. The first time the document is completely reprinted it will be called "Rev A" to the document; and each page of the document, whether text, table, figure, or drawing, will be labeled "Rev A." The second printing will be called "Rev B," the third "Rev C," et cetera. If a document is revised by reprinting only some of the pages, such a publication is called a PCN (page change notice). PCN's are issued against either a basic or a revised document, and every page of a particular PCN is labeled accordingly, for example, "Rev A, PCN-1" or "Rev A, PCN-1, New Page." A document, then, might go through the following publications: Basic; PCN-1; PCN-2; Rev A; Rev A, PCN-1; Rev A, PCN-2; Rev A, PCN-3; Rev B.

Every systems handbook document will contain table of contents and item effectivity pages in the front of the book. This table will list all the items in the document and name the most recent publication of each item. The table itself is updated and republished with each PCN or revision to the document.

ALSEP A2

BASIC, PCN-1

APRIL 15, 1971

TABLE OF CONTENTS AND ITEM EFFECTIVITY

ITEM	TITLE	HANDBOOK PUB	SIGNOFF DATE	PAGE	REMARKS
<u>SECTION 1 INTRODUCTORY INFORMATION</u>					
PAR 1.1	ABBREVIATIONS AND ACRONYMS	BASIC	2/15/71	1-1	
PAR 1.2	DRAWING SYMBOL STANDARDS	BASIC	2/15/71	1-7	
<u>SECTION 2 GENERAL DESCRIPTION</u>					
PAR 2.1	ALSEP DESCRIPTION	BASIC	2/15/71	2-1	
FIG 2-1	ALSEP/LM INTERFACE	BASIC	2/15/71	2-2	
FIG 2-2	ALSEP SUBPACKAGE 1	BASIC	2/15/71	2-3	
FIG 2-3	ALSEP SUBPACKAGE 2	BASIC	2/15/71	2-4	
<u>SECTION 3 STRUCTURAL/THERMAL CONTROL SUBSYSTEM</u>					
DWG 3.1	SUNSHIELD	BASIC	3/16/71	3-1	
DWG 3.2	THERMAL PLATE	BASIC	3/16/71	3-2	
DWG 3.3	PRIMARY STRUCTURE	BASIC	3/16/71	3-3	
DWG 3.4	THERMAL BAG	BASIC	3/16/71	3-4	
DWG 3.5	CENTRAL STATION SENSORS, HEATERS, AND SWITCHES	BASIC BASIC	3/16/71	3-5 3-5	
<u>SECTION 4 ELECTRICAL POWER SUBSYSTEM</u>					
PAR 4.1	SYSTEM DESCRIPTION	BASIC	2/15/71	4-1	
TAB 4-I	PCU OVER AND UNDER VOLTAGE	BASIC	2/15/71	4-8	
TAB 4-II	POWER CALCULATIONS	BASIC	2/15/71	4-8	
TAB 4-III	PDU RELAY INITIAL CONDITIONS	BASIC	2/15/71	4-9	
DWG 4.1	RTG TEMPERATURE SENSOR LOCATIONS	BASIC	3/16/71	4-10	
FIG 4-1	RTG WARMUP CHARACTERISTICS	BASIC	2/15/71	4-11	
FIG 4-2	RTG HOT AND COLD FRAME TEMPERATURES VERSUS RTG CURRENT	BASIC	2/15/71	4-12	
FIG 4-3	POWER DISSIPATION DISTRIBUTION	BASIC	2/15/71	4-13	
FIG 4-4	PCU LOAD VS RTG POWER OUTPUT VS CENTRAL STATION DISSIPATION	BASIC	2/15/71	4-14	
FIG 4-5	INTERNAL REGULATOR DISSIPATION	BASIC	2/15/71	4-15	
TAB 4-IV	CIRCUIT BREAKER AND FUSE TABULATION	BASIC	2/15/71	4-16	
TAB 4-V	VOLTAGE DISTRIBUTION AND BUS LOAD ANALYSIS	BASIC	2/15/71	4-17	
TAB 4-VI	COMMANDS CAUSING DELTA POWER DEMANDS	BASIC	2/15/71	4-18	
TAB 4-VII	CENTRAL STATION STEADY STATE POWER DEMANDS ON EACH VOLTAGE BUS FROM THE PCU	BASIC	2/15/71	4-20	
TAB 4-VIII	RELAY DRIVER FUNCTIONS AND INPUT VOLTAGE REQUIREMENTS	BASIC	2/15/71	4-21	
FIG 4-6	RELAY DRIVER VOLTAGES	BASIC	2/15/71	4-21	
DWG 4.2	POWER DISTRIBUTION AND FUNCTIONAL BLOCK DIAGRAM	BASIC	3/16/71	4-22	

TABLE OF CONTENTS AND ITEM EFFECTIVITY APRIL 15, 1971 (CONTINUED)

ITEM	TITLE	HANDBOOK PUB	SIGNOFF DATE	PAGE	REMARKS
<u>SECTION 5 COMMAND SUBSYSTEM</u>					
PAR 5.1	SYSTEM DESCRIPTION	BASIC	2/15/71	5-1	
FIG 5-1	COMMAND DECODER FLOW DIAGRAM	BASIC	2/15/71	5-10	
PAR 5.2	COMMAND FUNCTIONS	BASIC	2/15/71	5-11	
TAB 5-I	PRESET AND LUNAR INITIAL CONDITIONS	BASIC	2/15/71	5-38	
DWG 5.1	COMMAND SUBSYSTEM	BASIC		5-40	
<u>SECTION 6 TELEMETRY SUBSYSTEM</u>					
PAR 6.1	SYSTEM DESCRIPTION	BASIC	2/15/71	6-1	
FIG 6-1	DATA PROCESSOR FLOW DIAGRAM	BASIC	2/15/71	6-5	
TAB 6-I	ANALOG MULTIPLEXER, A/D CONVERTER CHARACTERISTICS	BASIC	2/15/71	6-6	
TAB 6-II	DIGITAL DATA PROCESSOR CHARACTERISTICS	BASIC	2/15/71	6-6	
FIG 6-2	MAIN FRAME FORMAT	BASIC	2/15/71	6-7	
FIG 6-3	CONTROL AND COMMAND VERIFICATION WORD FORMAT	BASIC	2/15/71	6-8	
TAB 6-III	TIMING FROM DIGITAL PROCESSOR	BASIC	2/15/71	6-9	
TAB 6-IV	TIMING AND CONTROL PULSE CHARACTERISTICS	BASIC	2/15/71	6-9	
TAB 6-V	TELEMETRY SUBSYSTEM POWER REQUIREMENTS AND OVERLOAD PROTECTION	BASIC	2/15/71	6-10	
TAB 6-VI	TRANSMITTER CHARACTERISTICS	BASIC	2/15/71	6-10	
TAB 6-VII	CHANNEL AND MEASUREMENT ASSIGNMENTS FOR ANALOG MULTIPLEXER (ALSEP WORD 33)	BASIC	2/15/71	6-11	
TAB 6-VIII	EXPERIMENT OFF DOWNLINK STATUS	BASIC	2/15/71	6-12	
TAB 6-IX	ANALOG CHANNEL USAGE	BASIC	2/15/71	6-13	
TAB 6-X	PSE MEASUREMENTS	BASIC	2/15/71	6-15	
TAB 6-XI	LSM MEASUREMENTS	BASIC	2/15/71	6-16	
TAB 6-XII	LSM 16 POINT ENGINEERING SUBCOMMUTATION FORMAT AND ENGINEERING STATUS BIT STRUCTURE LOCATED IN ALSEP MAIN FRAME, WORD 5	BASIC	2/15/71	6-17	
FIG 6-4	SWS WORD FORMAT	BASIC	2/15/71	6-18	
TAB 6-XIII	SWS MEASUREMENTS	BASIC	2/15/71	6-19	
TAB 6-XIV	LIMITS OF SWS ENGINEERING DATA	BASIC	2/15/71	6-23	
FIG 6-5	SIDE WORD FORMAT	BASIC	2/15/71	6-24	
TAB 6-XV	SIDE/CCGE MEASUREMENTS	BASIC	2/15/71	6-25	
FIG 6-6	HFE WORD FORMAT	BASIC	2/15/71	6-31	
TAB 6-XVI	HFE MEASUREMENTS, MODES 1 AND 2, GRADIENT AND LOW CONDUCTIVITY	BASIC	2/15/71	6-32	
TAB 6-XVII	HFE MEASUREMENTS, MODE 3, HIGH CONDUCTIVITY	BASIC	2/15/71	6-33	
TAB 6-XVIII	HFE MEASUREMENTS, ANALOG	BASIC	2/15/71	6-33	
DWG 6.1	TELEMETRY SUBSYSTEM	BASIC	3/16/71	6-34	
DWG 6.2	MECHANICAL ANALOGY OF TELEMETRY COMMUTATIONS	BASIC	3/16/71	6-35	
DWG 6.3	CENTRAL STATION AND RTG INSTRUMENTATION DIAGRAM	BASIC	3/16/71	6-36	
<u>SECTION 7 DTREM SUBSYSTEM (M-515)</u>					
PAR 7.1	SYSTEM OBJECTIVES	BASIC	2/15/71	7-1	
PAR 7.2	EQUIPMENT DESCRIPTION	BASIC	2/15/71	7-1	
PAR 7.3	EXPERIMENT OPERATION	BASIC	2/15/71	7-2	
FIG 7-1	DTREM	BASIC	2/15/71	7-3	
DWG 7.1	DTREM SCHEMATIC	BASIC	3/16/71	7-4	

TABLE OF CONTENTS AND ITEM EFFECTIVITY APRIL 15, 1971 (CONTINUED)

ITEM	TITLE	HANDBOOK PUB	SIGNOFF DATE	PAGE	REMARKS
<u>SECTION 8 PASSIVE SEISMIC EXPERIMENT (S-031)</u>					
PAR 8.1	SYSTEM DESCRIPTION	BASIC	2/15/71	8-1	
TAB 8-I	PSE PRESET CONDITIONS	BASIC	2/15/71	8-3	
TAB 8-II	PSE LEVELING RATES	BASIC	2/15/71	8-3	
FIG 8-1	PSE POWER PROFILE	BASIC, PCN-1	4/15/71	8-4	
DWG 8.1	PSE SYSTEM SCHEMATIC	BASIC	3/16/71	8-5	
<u>SECTION 9 LUNAR SURFACE MAGNETOMETER EXPERIMENT (S-034)</u>					
PAR 9.1	SYSTEM DESCRIPTION	BASIC	2/15/71	9-1	
TAB 9-I	LSM PRESET CONDITIONS	BASIC	2/15/71	9-2	
FIG 9-1	LSM POWER PROFILE	BASIC	2/15/71	9-3	
PAR 9.2	FLIP-CALIBRATION SEQUENCE	BASIC	2/15/71	9-4	
DWG 9.1	LSM FLIP-CALIBRATION SEQUENCE	BASIC	3/16/71	9-6	
PAR 9.3	SITE-SURVEY SEQUENCE	BASIC	2/15/71	9-7	
DWG 9.2	LSM X, Y, Z SITE-SURVEY SEQUENCES	BASIC	3/16/71	9-10	
DWG 9.3	LSM SYSTEM SCHEMATIC	BASIC	3/16/71	9-11	
<u>SECTION 10 SOLAR WIND SPECTROMETER EXPERIMENT (S-035)</u>					
PAR 10.1	SYSTEM DESCRIPTION	BASIC	2/15/71	10-1	
FIG 10-1	SWS POWER PROFILE	BASIC, PCN-1	4/15/71	10-4	
FIG 10-2	SWS TELEMETRY FORMAT	BASIC	2/15/71	10-5	
DWG 10.1	SWS SYSTEM SCHEMATIC	BASIC	3/16/71	10-6	
<u>SECTION 11 SUPRATHERMAL ION DETECTOR EXPERIMENT/COLD CATHODE GAGE EXPERIMENT (S-036)</u>					
PAR 11.1	SYSTEM DESCRIPTION	BASIC	2/15/71	11-1	
TAB 11-I	SIDE/CCGE PRESET CONDITIONS	BASIC	2/15/71	11-3	
TAB 11-II	GROUND PLANE STEPPER SEQUENCE	BASIC	2/15/71	11-3	
TAB 11-III	SIDE WORD 2 TELEMETRY	BASIC	2/15/71	11-4	
FIG 11-1	SIDE/CCGE POWER PROFILE	BASIC	2/15/71	11-5	
FIG 11-2	PROGRAMED SENSOR VOLTAGE VARIATIONS (NORMAL CYCLE)	BASIC	2/15/71	11-6	
FIG 11-3	PROGRAMED SENSOR VOLTAGE VARIATIONS (RESET AT 10)	BASIC	2/15/71	11-7	
FIG 11-4	PROGRAMED SENSOR VOLTAGE VARIATIONS (RESET AT 39 AND 79)	BASIC	2/15/71	11-8	
FIG 11-5	PROGRAMED SENSOR VOLTAGE VARIATIONS (RESET AT 9)	BASIC	2/15/71	11-9	
FIG 11-6	SIDE TEMP SENSORS, HEATER, AND THERMOSTAT LOCATIONS	BASIC	2/15/71	11-10	
DWG 11.1	SIDE/CCGE SYSTEM SCHEMATIC	BASIC	3/16/71	11-11	
<u>SECTION 12 HEAT FLOW EXPERIMENT (S-037)</u>					
PAR 12.1	SYSTEM DESCRIPTION	BASIC	2/15/71	12-1	
PAR 12.2	HFE MODES	BASIC	2/15/71	12-1	
TAB 12-1	HFE MEASUREMENT OPTIONS (MODES 1 AND 2)	BASIC	2/15/71	12-3	
FIG 12-1	HFE POWER PROFILE	BASIC, PCN-1	4/15/71	12-4	
FIG 12-2	HEAT FLOW EXPERIMENT	BASIC	2/15/71	12-5	
FIG 12-3	HEAT FLOW BLOCK DIAGRAM	BASIC	2/15/71	12-6	
FIG 12-4	HEAT FLOW PROBE MEASUREMENT SEQUENCES	BASIC	2/15/71	12-7	
DWG 12.1	HFE SYSTEM SCHEMATIC	BASIC		12-8	



TABLE OF CONTENTS AND ITEM EFFECTIVITY APRIL 15, 1971 (CONCLUDED)

ITEM	TITLE	HANDBOOK PUB	SIGNOFF DATE	PAGE	REMARKS
<u>SECTION 13 APOLLO LUNAR SURFACE DRILL</u>					
PAR 13.1	SYSTEM DESCRIPTION	BASIC	2/15/71	13-1	
FIG 13-1	ALSD ASSEMBLY, STOWAGE, AND LUNAR OPERATING SEQUENCE				
PAR 13.2	ALSD PHYSICAL DESCRIPTION	BASIC	2/15/71	13-3	
TAB 13-1	ALSD LEADING PARTICULARS	BASIC	2/15/71	13-6	
PAR 13.3	ALSD FUNCTIONAL DESCRIPTION	BASIC	2/15/71	13-7	
FIG 13-2	ALSD POWER HEAD, SIMPLIFIED CUTAWAY VIEW				

SECTION 1  
INTRODUCTORY INFORMATION

1.1 ABBREVIATIONS AND ACRONYMS

NOTE

Due to reduction requirements, acronyms which would normally be in lower case, for example, "dc," will appear in upper case on drawings. The text will, however, conform to NASA standards.

ac	alternating current
ACCPY	accept
ACK	acknowledge
A/DC	analog-to-digital converter
Adc	amperes dc
ADD	address
AGC	automatic gain control
ALHT	Apollo lunar hand tools
ALIGN	alignment
ALSD	Apollo lunar surface drill
ALSEP	Apollo Lunar Surface Experiments Package
A/F	automatic/forced
AMPS	amperes
ANT	antenna
APP	approximate, approximately
ARM	armed
ASC	ascent
ASE	Active Seismic Experiment
ASI	Apollo standard initiator
AUTO	automatic
AZ	azimuth
BL	bottom location of structure temperature
BAS	base
BER	bit error rate
BFS	bits per second
C	centigrade
CAL	calibrate
CALC	calculated
CB	circuit breaker
CBL	cable
CCGE	Cold Cathode Gage Experiment (part of SIDE on ALSEP 1, 4, and A2, separate MSC experiment on ALSEP 3)
CCGE/A }	analog and digital ID readout from CCGE
CCGE/D }	
CCIG	Cold Cathode Ion Gage (instrument portion of CCGE)
CCW	counterclockwise
CH	channel
CH	change
CHAN	Channeltron; used in CPE as: CHAN/1 Channeltron P/S #1 CHAN/2 Channeltron P/S #2 CHAN/HI Channeltron Voltage Increase ON CHAN/LO Channeltron Voltage Increase OFF
CLD	cold
CMD	command
CNT	count

CNTS	counts
CNTR	counter
COMM	communications
CONV	converter
CPLEE or CPE	Charged-Particle Experiment (full name is Charged-Particle Lunar Environment Experiment)
CPS	cycles per second
CS	central station
CTL	control
CUR	current
CVR	cover
CVR/S	cover and seal (used on SIDE)
CVW	command verification word
CW	clockwise
db	decibels
dbm	decibels with respect to one milliwatt
dc	direct current
DEC	decoder
DECR	decrease
DEF	deflection
DEG	degrees
DESC	descent
DET	detector
DIG	digital
DIR	direction
DIR/V	direction and speed (used on PSE)
DISSIP	dissipation
DLAY	delay
D/P	data processor
DPLY	deploy
DRT	dome removal tool
DSS	Data Subsystem
DSS/A	Analog Data Processor
DSS/D	Digital Data Processor
DSS/PROC	Complete Data Processor (Redundant)
DTREM	Dust, Thermal, and Radiation Engineering Measurements Package
EGFU	Electronics/Gimbal-Flip Unit
ENBL	enable
EPS	Electrical Power System
eV	electron volts
EXP	experiment
EXT	external
F	fuse
F	Fahrenheit
FET	field effect transistor
FILT	filter
FLD	field
FREQ	frequency
FTT	fuel transfer tool
FWD	forward

GDT gradient sensor delta temperatures (HFE)  
 GEO geophone  
 GLA Grenade Launch Assembly (a component of ASE)  
 GMBL gimbal  
 GND ground  
 GT gradient sensor ambient temperatures (HFE)

HBR high bit rate  
 HE high explosive (ASE grenades)  
 HECPA High-Energy Curved-Plate Analyzer (a component of SIDE)  
 HFE Heat Flow Experiment  
 HI high  
 HTR heater: On HFE there are two cases:  
     HTR/HK High Conductivity Heater  
     HTR/LK Low Conductivity Heater

HS heat sink  
 HV high voltage  
 Hz hertz

ID identification  
 IN input  
 INCR increase  
 IND indication  
 INHIB inhibit  
 INIT initiate  
 INST instrument  
 INSUL insulation  
 INT internal

K Kelvin  
 kbps kilobits per second  
 kc kilocycles  
 kHz kilohertz  
 kV kilovolts

LAT latitude  
 LBR low bit rate  
 LECPA Low-Energy Curved-Plate Analyzer (a component of SIDE)  
 LIM limit  
 LM Lunar Module  
 LO low  
 LONG longitude  
 L/O local oscillator  
 LOS loss of signal  
 LP long period (PSE sensors)  
 LSB least significant bit  
 LSD least significant data  
 LSM Lunar Surface Magnetometer  
 LVL level

mA milliampere  
 mAdc milliamperes dc  
 MAP message acceptance pulse

MAX	maximum
Mc	megacycle
MCC	Mission Control Center
MDE	mode
MEAS	measurement
MeV	million electron volts
MHz	megahertz
MIN	minimum
MOCR	Mission Operations Control Room
MOD	module
MODE	operating modes are defined as follows:  <div style="margin-left: 40px;"> <p><u>For HFE</u></p> <p>MODE/G gradient mode</p> <p>MODE/HK high conductivity mode</p> <p>MODE/LK low conductivity mode</p> </div>
ms	millisecond
MSB	most significant bit
MSD	most significant data
MSP	measurement sequence programmer
MSFN	Manned Space Flight Network
MTR	motor; on PSE, the three motors are MTRX, MTRY, and MTRZ
MUX	multiplexer or multiplex
mV	millivolts
mW/cm <sup>2</sup>	milliwatts per square centimeter
na	nanoamperes
N/A	not applicable
NBR	normal bit rate
NEG	negative
NORM	normal
NRZC	Non-Return to Zero Type C (Change)
OPER	operate
O/S	offset
OSC	oscillator
O/T	one-time
OUT	output
PA	power amplifier
pA	picoamperes
PCM	pulse code modulation
PCT	percent
PCU	Power Conditioning Unit
PDM	Power Dissipation Module
PDR	power dissipation resistor
PDU	Power Distribution Unit
PET	package elapsed time
PHYS	physical; on CPE used as follows: <div style="margin-left: 40px;"> <p>PHY/AN Physical Analyzer (sensor assembly)</p> </div>
PKG	package
PL	plane
PLT	plate
PM	phase modulation
POS	positive

POSN position  
 PRE/LIM prelimiting  
 PRE/REG preregulator (a component of the SIDE power supply)  
 PRI primary; on ALSEP used as follows:  
     PRI/ST primary structure  
 P/S power supply  
 PSE Passive Seismic Experiment; also:  
     PSE/LP long-period sensors  
     PSE/SP short-period sensors  
     PSE/LF/SP long- and short-period sensors  
     Long-period sensors are further defined as PSE/X, PSE/Y, and PSE/Z, while  
     PSE/XY denotes the two horizontal long-period sensors  
 PWR power  
  
 R resistor (used as R1 and R2)  
 RCVD received  
 RCVR receiver  
 RDT ring sensor delta temperature (HFE)  
 REF reference  
 REG regulator (also used as "register" on ALSEP)  
 REV reverse  
 RF radio frequency  
 RLY relay  
 R/S remote site  
 RST reset  
 RT rate (as in BIT RT, CNT RT, etc.)  
 RT ring sensor ambient temperatures (HFE)  
 RTC real-time command  
 RTE real-time event  
 RTG Radioisotope Thermoelectric Generator  
  
 SCI scientific  
 SEC second  
 SEL select  
 SEQ sequence, sequential; used on HFE as:  
     SEQ/FUL Full Sequence  
     SEQ/P1 Probe 1 Sequence  
     SEQ/P2 Probe 2 Sequence  
     Used on ASE as:  
     SEQ/S Sequential Single  
 SEQ scientific equipment  
 SIDE Suprathermal Ion Detector Experiment; also:  
     SIDE/A } analog and digital voltages  
     SIDE/D } or readings  
     SIDE/HE high-energy data  
     SIDE/LE low-energy data  
     SIDE/LHE least significant high-energy digital data  
     SIDE/LLE least significant low-energy digital data  
     SIDE/MHE most significant high-energy digital data  
     SIDE/MLE most significant low-energy digital data  
 SIG signal  
 SLA Spacecraft Lunar Module Adapter  
 SNSR sensor

SP short period (PSE sensor)  
 SPST single pole single throw  
 STA status  
 STBY standby  
 S/S samples per second, signal strength  
 S/T structural/thermal  
 SWS Solar Wind Spectrometer  
 SYNC synchronization  
 SW switch  
 SUP supply  
 SYS system  
  
 T temperature (also used as "thermal" on ALSEP)  
 TC thermocouple (on HFE, four cable ambient temperatures are read on each probe)  
 T/D time delay  
 TEMP temperature  
 THERM thermal  
 TM telemetry  
  
 UHT Universal Handling Tool  
 USB unified S-band  
  
 V volts, velocity (used to indicate "speed" on PSE in "LVL DIR/V")  
 Vac volts ac  
 Vdc volts dc  
 VCO voltage controlled oscillator  
 V/FILT Velocity Filter, a component of SIDE  
  
 W watts  
 W1, W2, W3 wall locations of structure temperature sensors  
  
 XMTR transmitter  
 XTAL crystal  
 XYZ } axes of LSM, where XYO indicates  
 XYO } X, or Y, or neither  
  
 φ phase

1.2 DRAWING SYMBOL STANDARDS

1.2.1 GENERAL DRAWING INFORMATION

A. ZONE REFERENCE

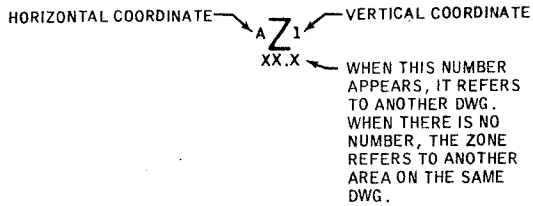

B. POWER INTRA-DRAWING ZONE REFERENCE

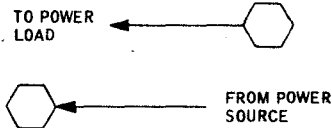

C. SYSTEM INTERCONNECT

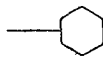

D. DRAWING NOTE REFERENCE



1.2.2 LINE LEGEND

A. RF CABLE

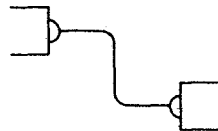

B. ELECTRICAL LINE, POWER AND CONTROL



1. ELECTRICAL, CONNECTED



2. ELECTRICAL, CROSSOVER

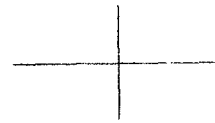

C. DIRECTIONAL FLOW ARROWS



D. COMPONENT ENCLOSURES (TYPICAL)

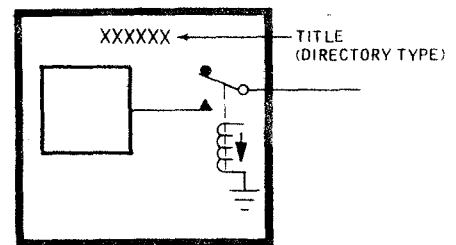

- 1. MAIN ENCLOSURE
- 2. SUB ENCLOSURE
- 3. COMPONENT ENCLOSURE WITH CREW (MANUAL CONTROL)
- 4. EXPERIMENT INTERFACE

**EXPERIMENT**  **ALSEP**

E. MECHANICAL LINKAGE

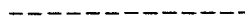

F. TIMING PULSES

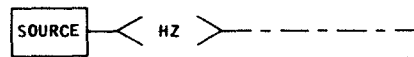

G. TWO-UNIT INTERFACE

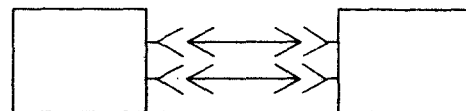



1.2.3 TELEMETRY SYMBOLS

A. MEASUREMENTS TELEMETERED

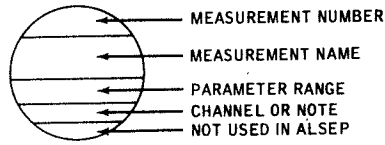

B. METERS



C. SINGLE SOURCE SENSOR

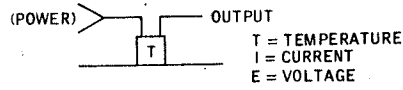

D. COMMANDS

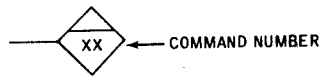

1.2.4 ELECTRICAL SYMBOLS

A. SWITCHES

1. MOMENTARY CONTACT

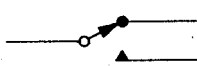

2. LATCHING CONTACT

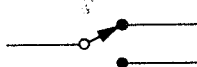

3. SOLID PUSHBUTTON

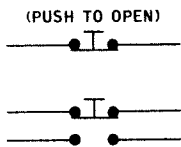

B. FUSES

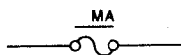

C. RELAYS

1. MOMENTARY CONTACTS

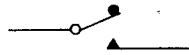

2. LATCHING CONTACTS



3. NON-LATCHING RELAY SHOWN IN DE-ENERGIZED POSITION

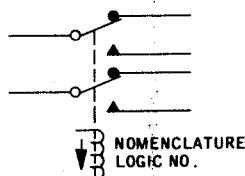

4. LATCHING RELAY

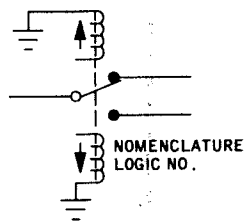

D. RELAY OR SOLENOID DRIVER

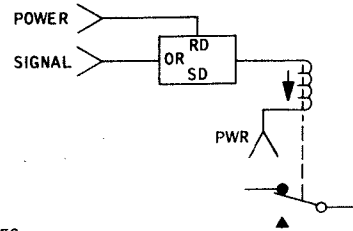

E. BUSES

1. SYMBOL (LENGTH MAY VARY)



2. DESIGNATION



F. GROUNDS

1. SYSTEM



2. FLOATING OR CONTROLLED

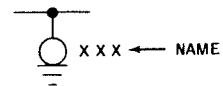

G. TRANSFORMERS

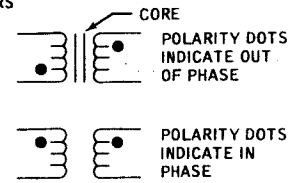

H. CAPACITOR

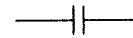

I. DIGITAL INVERTER

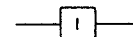

J. GATES

1. AND

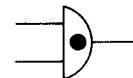

2. NAND

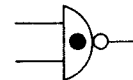

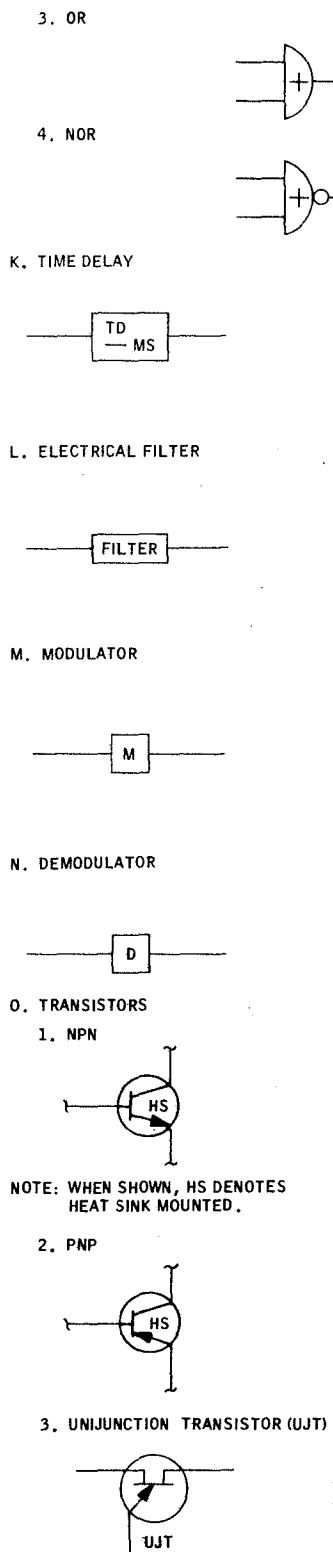

P. NON-AMPLIFYING DEVICE, IDENTIFIED

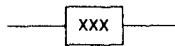

Q. DIODES

1. GENERAL



2. ZENER



3. CONTROL RECTIFIER



R. POTENTIOMETER

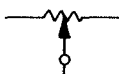

S. HEATER



T. FIXED RESISTOR

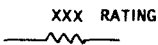

U. THERMISTOR



V. THERMOSTAT

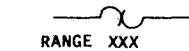

W. ANTENNA

NAME  
(TYPE OR FUNCTION)



X. PHOTOELECTRIC CELL



Y. AMPLIFIER

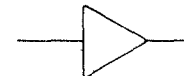
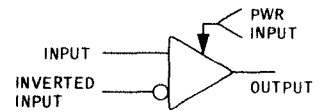

DC, PRE-, OR BUFFER AMPLIFIER  
AS INDICATED

Z. CIRCUIT BREAKERS

1. AUTOMATIC

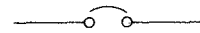

2. TWO-POLE, DOUBLE-THROW,  
AUTOMATIC

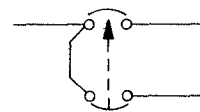

1.2.5 PYROTECHNIC SYMBOLS

A. EXPLOSIVE INITIATOR



1.2.6 SPECIAL ALSEP SYMBOLS

A. ASTRONAUT SWITCHES

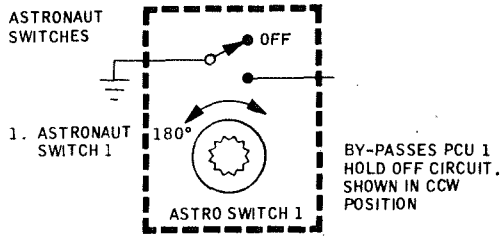

2. ASTRONAUT SWITCH 2

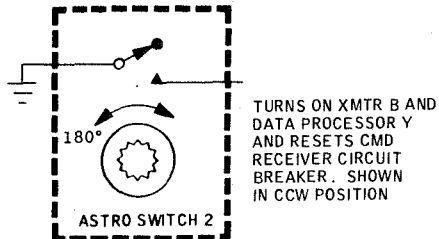

3. ASTRONAUT SWITCH 3

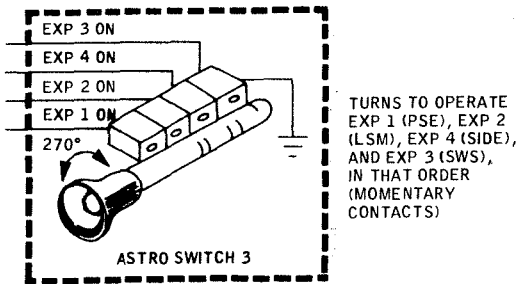

B. SIDE SENSOR ASSEMBLY

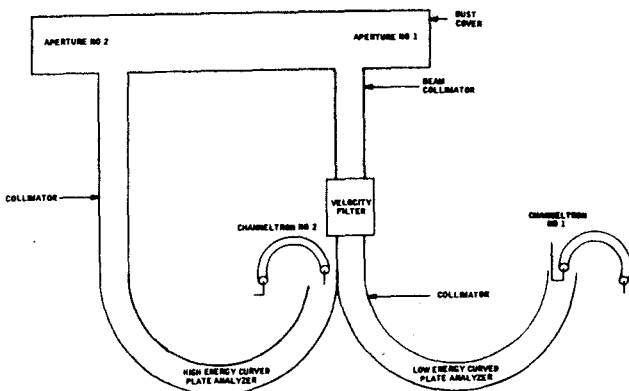

C. GROUND PLANE (USED ON SIDE)

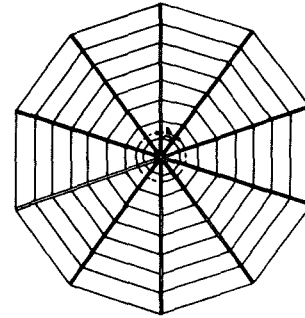

D. FARADAY CUP (SWS SENSOR)

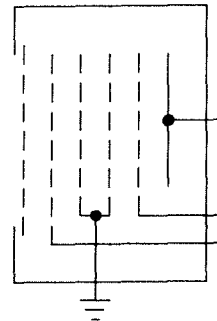

E. COLD CATHODE ION GAGE

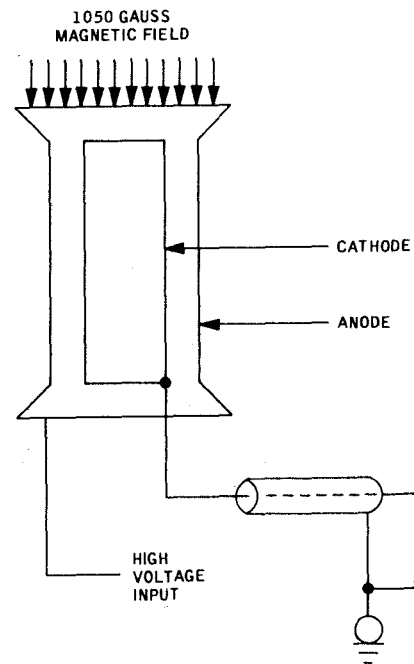

F. MOTOR (USED IN PSE AND LSM)

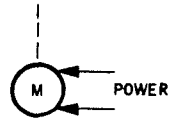

G. HEAT FLOW EXPERIMENT PROBE SECTION

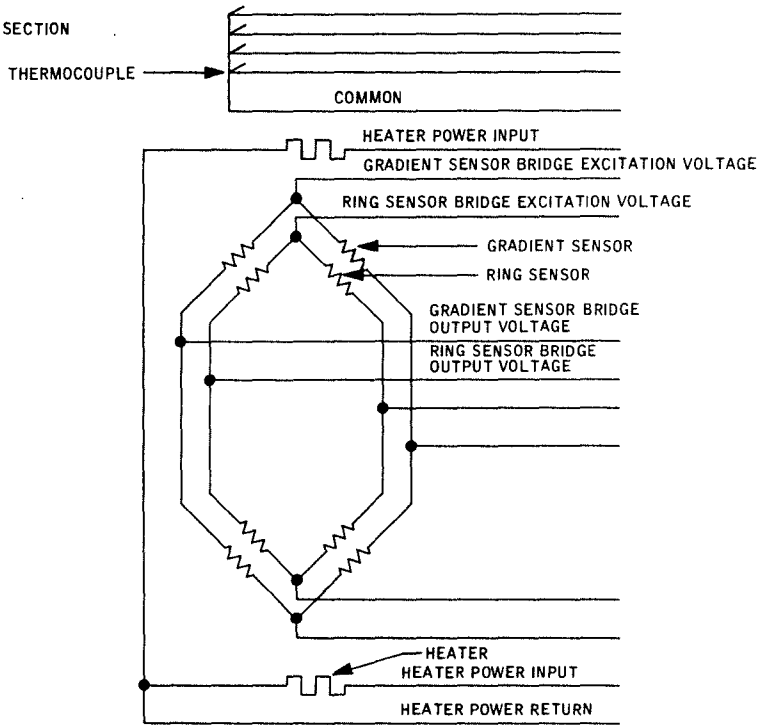

H. CHARGED PARTICLE LUNAR ENVIRONMENT EXPERIMENT

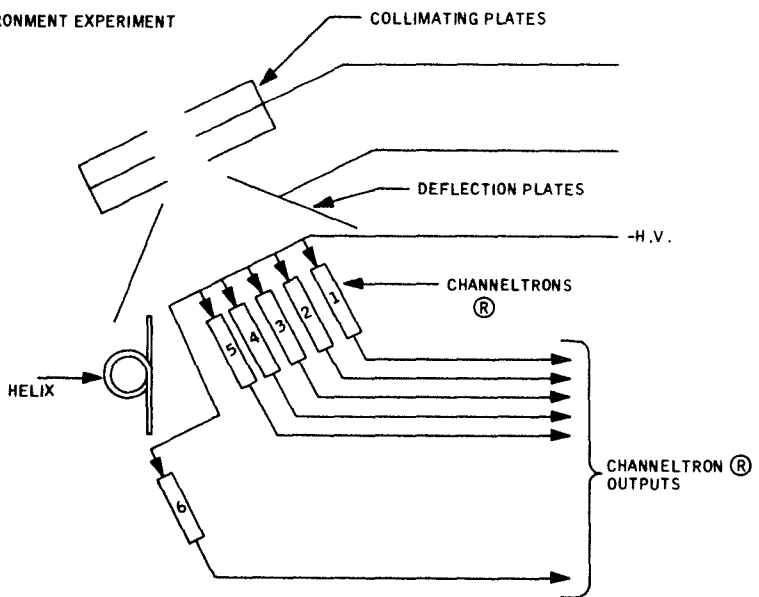

\*

SECTION 2

GENERAL DESCRIPTION

2.1 ALSEP DESCRIPTION

The Apollo lunar surface experiments package (ALSEP) system consists of a set of scientific instruments to be placed on the moon's surface by the Apollo flight crew. These instruments will remain on the moon to collect and transmit data for approximately 2 years. For self-sufficient operations, the ALSEP system includes a nuclear power supply, mechanical support, thermal protection, and data handling equipment. These supporting subsystems provide a central station containing the electrical power, command, telemetry, and structural/thermal subsystems to operate with various combinations of the following scientific experiment subsystems: passive seismic, active seismic, magnetometer, solar wind spectrometer, suprathreshold ion detector/cold cathode gage, heat flow, charged-particle lunar environment, and cold cathode gage. Weight and volume restrictions of the lunar module preclude carrying all eight experiment subsystems on any one flight. This ALSEP systems handbook deals with the ALSEP A2 package containing the PSE, LSM, SWS, SIDE/CCGE, and HFE (Figure 2-1).

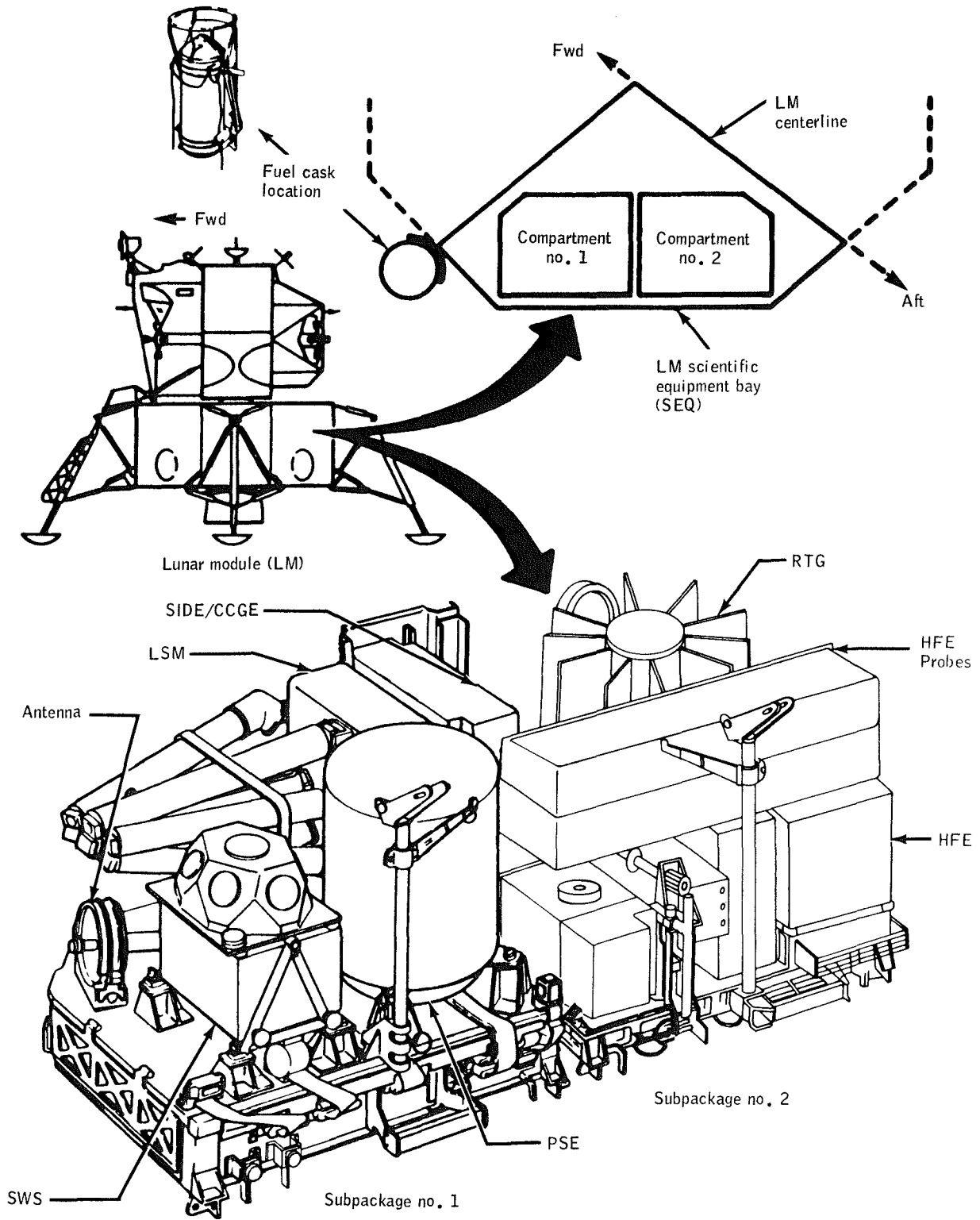

Figure 2-1. - ALSEP/LM interface.

FCD 2-77.23.58

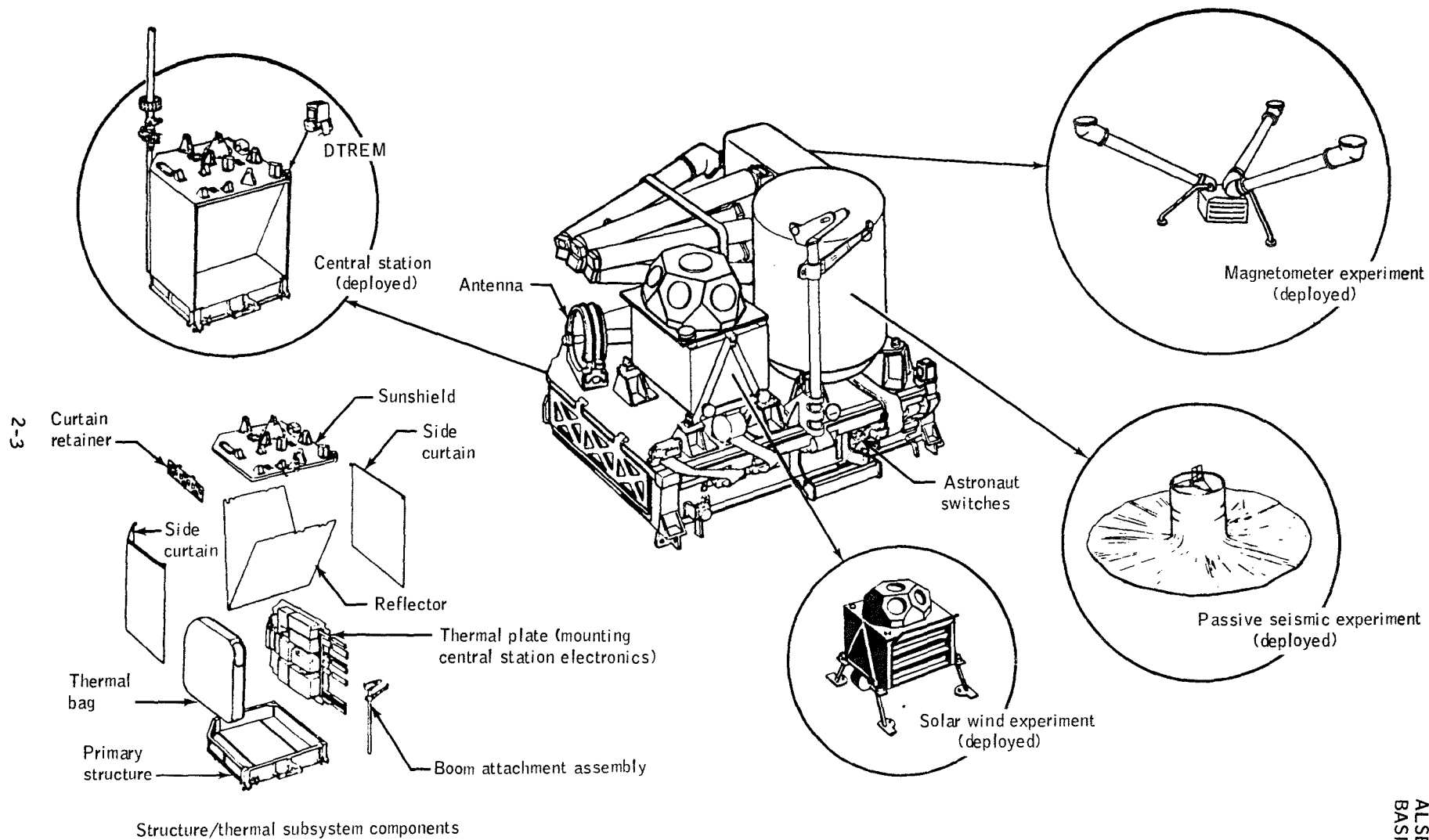

Figure 2-2.- ALSEP Subpackage 1.

2-4

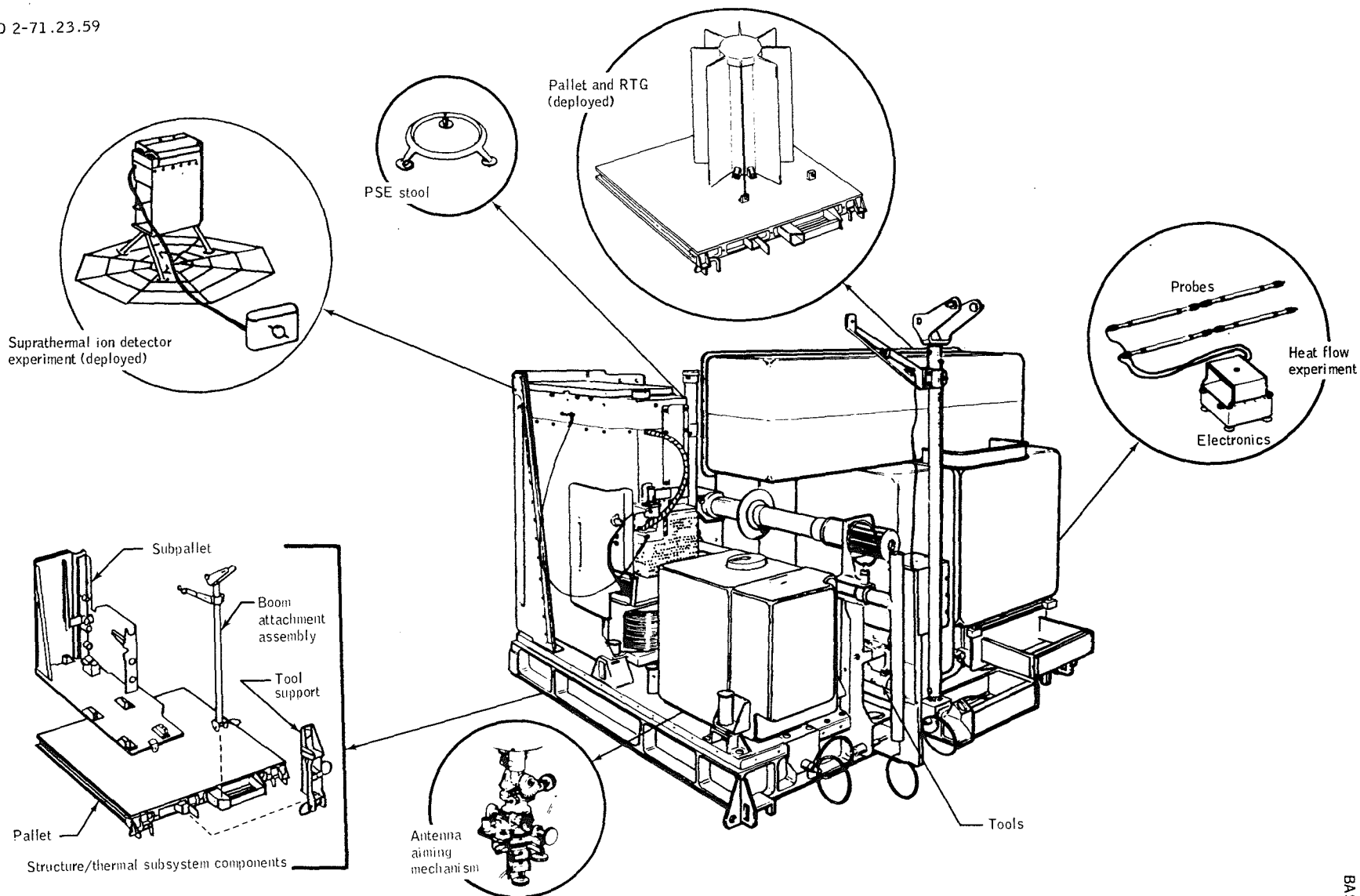

Figure 2-3. - ALSEP Subpackage 2.



D

C

B

A

LTR	PCN	DR	ENGR	DATE	APPROVAL
COMMENTS:					

4

4

3

3

2

2

1

1

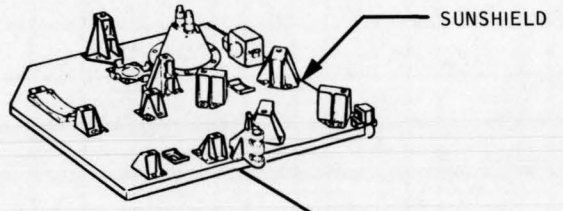

LH GNOMON ASSEMBLY

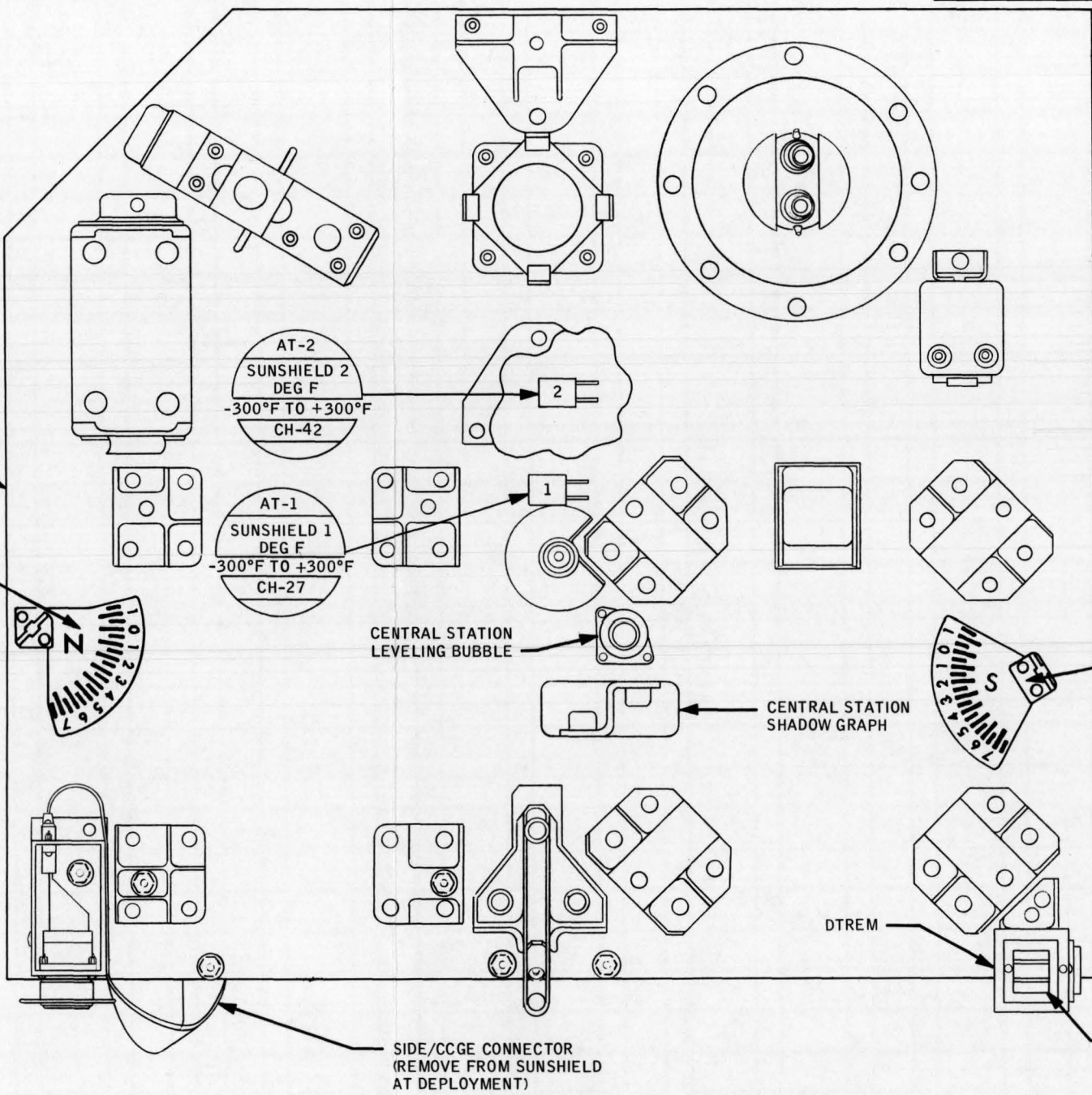

RH GNOMON ASSEMBLY

SIGNATURES		DATE	NATIONAL AERONAUTICS & SPACE ADMINISTRATION MANNED SPACECRAFT CENTER • HOUSTON, TEXAS		
DR	<i>Fant</i>	<i>1/21/71</i>	<b>SUNSHIELD</b>		
DSGN					
QC	<i>Betty M. Taylor</i>	<i>2/20/71</i>			
ENGR	<i>Paul Noring</i>	<i>1/20/71</i>			
APP	<i>James B.ault</i>	<i>1/20/71</i>	ALSEP A2	SIZE	DWG NO
FEC	<i>Dean B. Fisher</i>	<i>3/20/71</i>		<b>C<sub>1</sub></b>	<b>3.1</b>
			22 X 17	PAGE 3-1	SHEET 1 OF 1

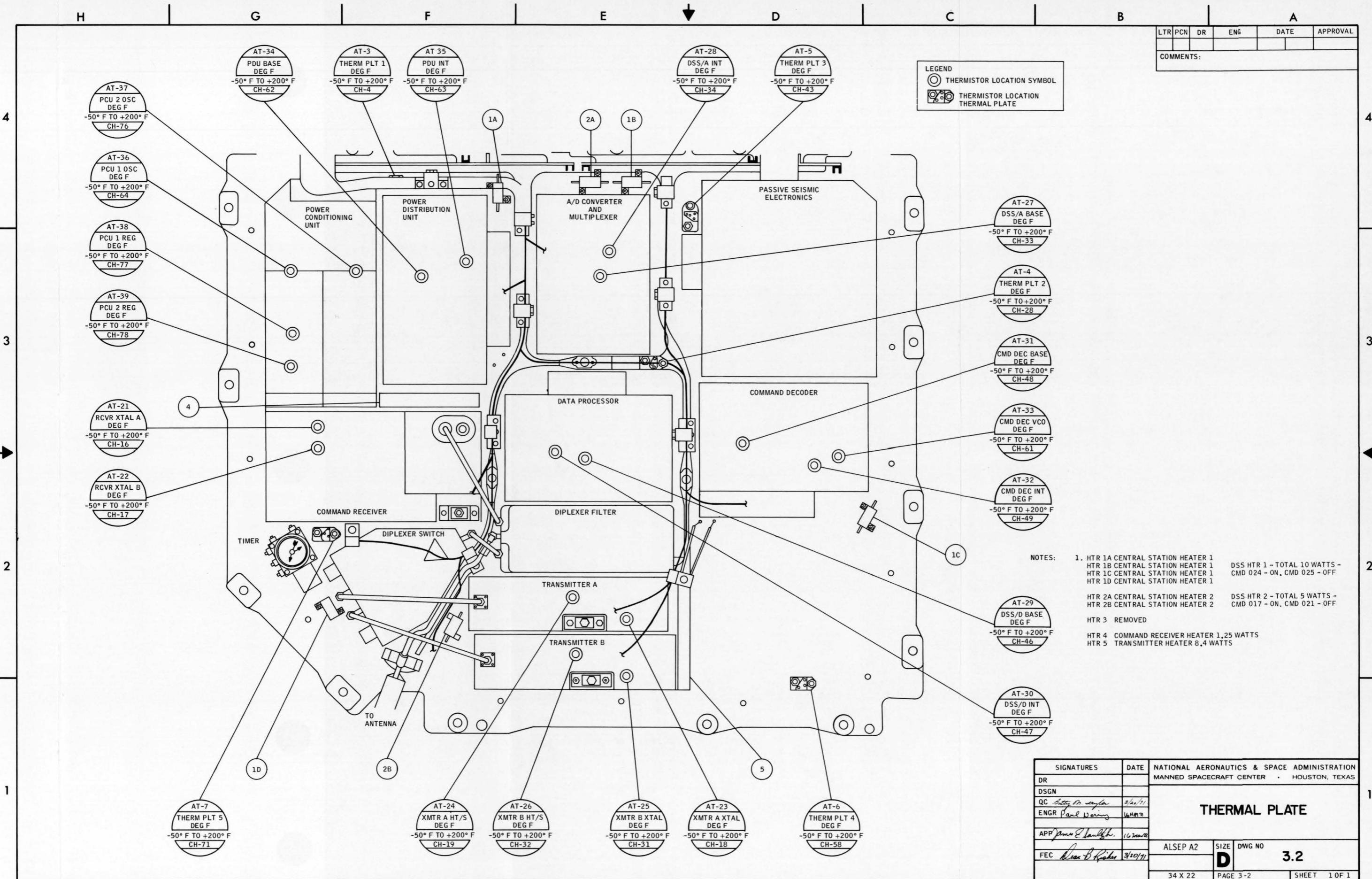

LTR	PCN	DR	ENG	DATE	APPROVAL

COMMENTS:

LEGEND  
 ○ THERMISTOR LOCATION SYMBOL  
 □ THERMISTOR LOCATION THERMAL PLATE

- NOTES:
- HTR 1A CENTRAL STATION HEATER 1  
 HTR 1B CENTRAL STATION HEATER 1  
 HTR 1C CENTRAL STATION HEATER 1  
 HTR 1D CENTRAL STATION HEATER 1  
 DSS HTR 1 - TOTAL 10 WATTS -  
 CMD 024 - ON, CMD 025 - OFF
  - HTR 2A CENTRAL STATION HEATER 2  
 HTR 2B CENTRAL STATION HEATER 2  
 DSS HTR 2 - TOTAL 5 WATTS -  
 CMD 017 - ON, CMD 021 - OFF
  - HTR 3 REMOVED
  - HTR 4 COMMAND RECEIVER HEATER 1,25 WATTS
  - HTR 5 TRANSMITTER HEATER 8,4 WATTS

SIGNATURES	DATE	NATIONAL AERONAUTICS & SPACE ADMINISTRATION MANNED SPACECRAFT CENTER HOUSTON, TEXAS	
DR		<b>THERMAL PLATE</b>	
DSGN			
QC <i>Cliff D. Taylor</i>	3/21/71		
ENGR <i>Paul Waring</i>	1/21/71		
APP <i>James E. Loughlin</i>	1/21/71	ALSEP A2	SIZE DWG NO
FEC <i>Alan B. Kisher</i>	3/10/71	<b>D</b>	<b>3.2</b>
		34 X 22	PAGE 3-2 SHEET 1 OF 1

H G F E D C B A

LTR	PCN	DR	ENGR	DATE	APPROVAL

COMMENTS:

4  
3  
2  
1

4  
3  
2  
1

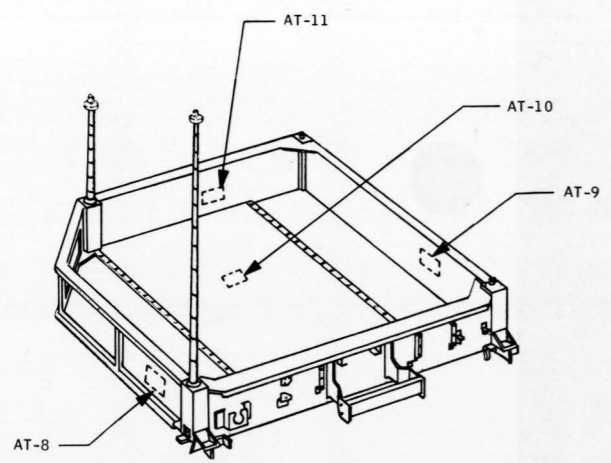

PRIMARY STRUCTURE

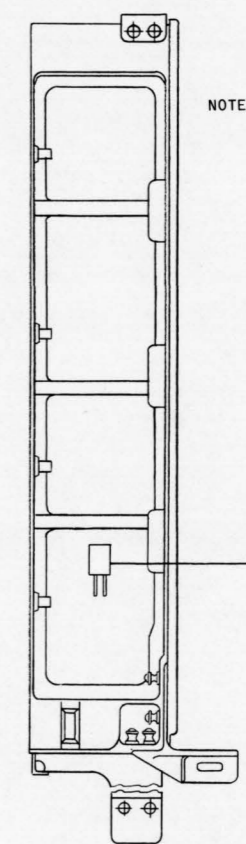
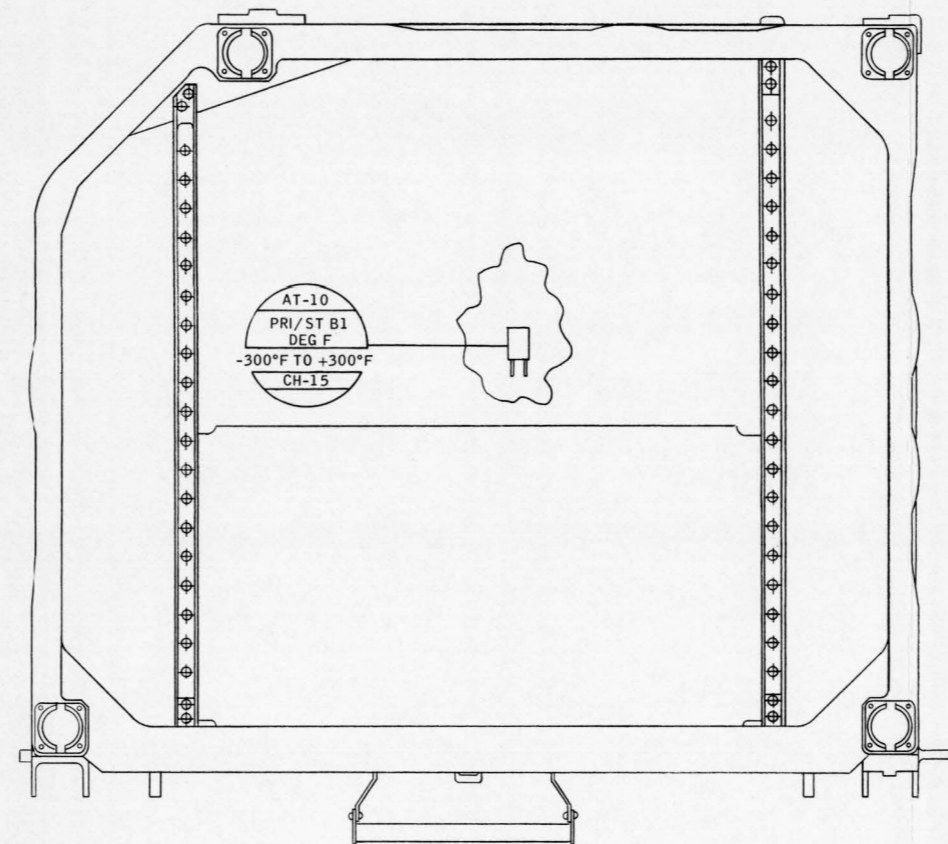
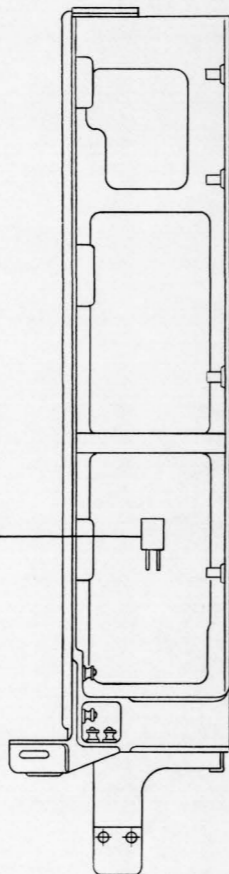
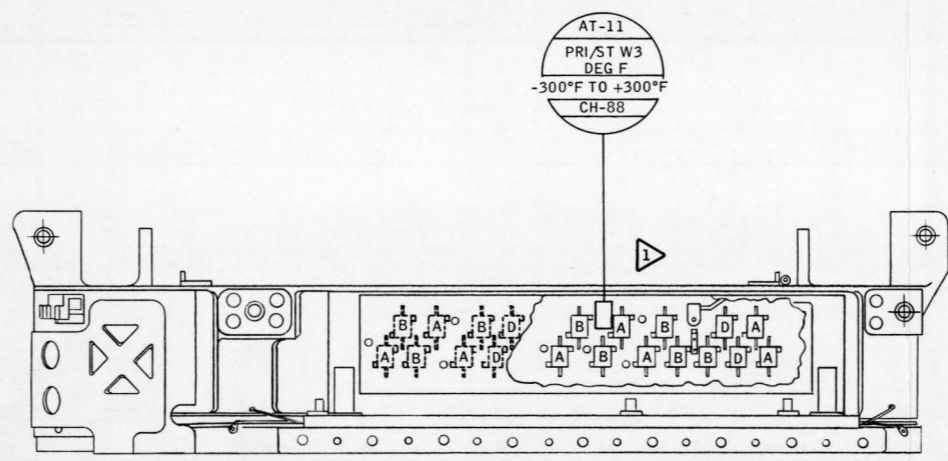

NOTE: 1 RESISTORS MARKED A - SHUNT REGULATOR 1  
RESISTORS 3.57Ω TOTAL  
RESISTORS MARKED B - SHUNT REGULATOR 2  
RESISTORS 3.57Ω TOTAL  
PDR 1 RESISTORS REMOVED  
RESISTORS MARKED D - PDR 2 RESISTORS  
60Ω TOTAL 14 WATTS

SIGNATURES		DATE	NATIONAL AERONAUTICS & SPACE ADMINISTRATION MANNED SPACECRAFT CENTER · HOUSTON, TEXAS	
DR			<b>PRIMARY STRUCTURE</b>	
DSGN				
QC <i>Sally M. Taylor</i>	3/20/71			
ENGR <i>Paul Norring</i>	1/6/71			
APR <i>James B. ...</i>	6/20/71			
FEC <i>Dean B. ...</i>	3/20/71		ALSEP A2	SIZE DWG NO
			<b>D</b>	<b>3.3</b>
			34 X 22	PAGE 3-3 SHEET 1 OF 1



D

C

B

A

LTR	PCN	DR	ENGR	DATE	APPROVAL
COMMENTS:					

4

4

3

3

2

2

1

1

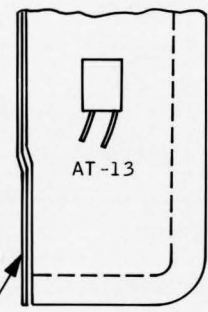
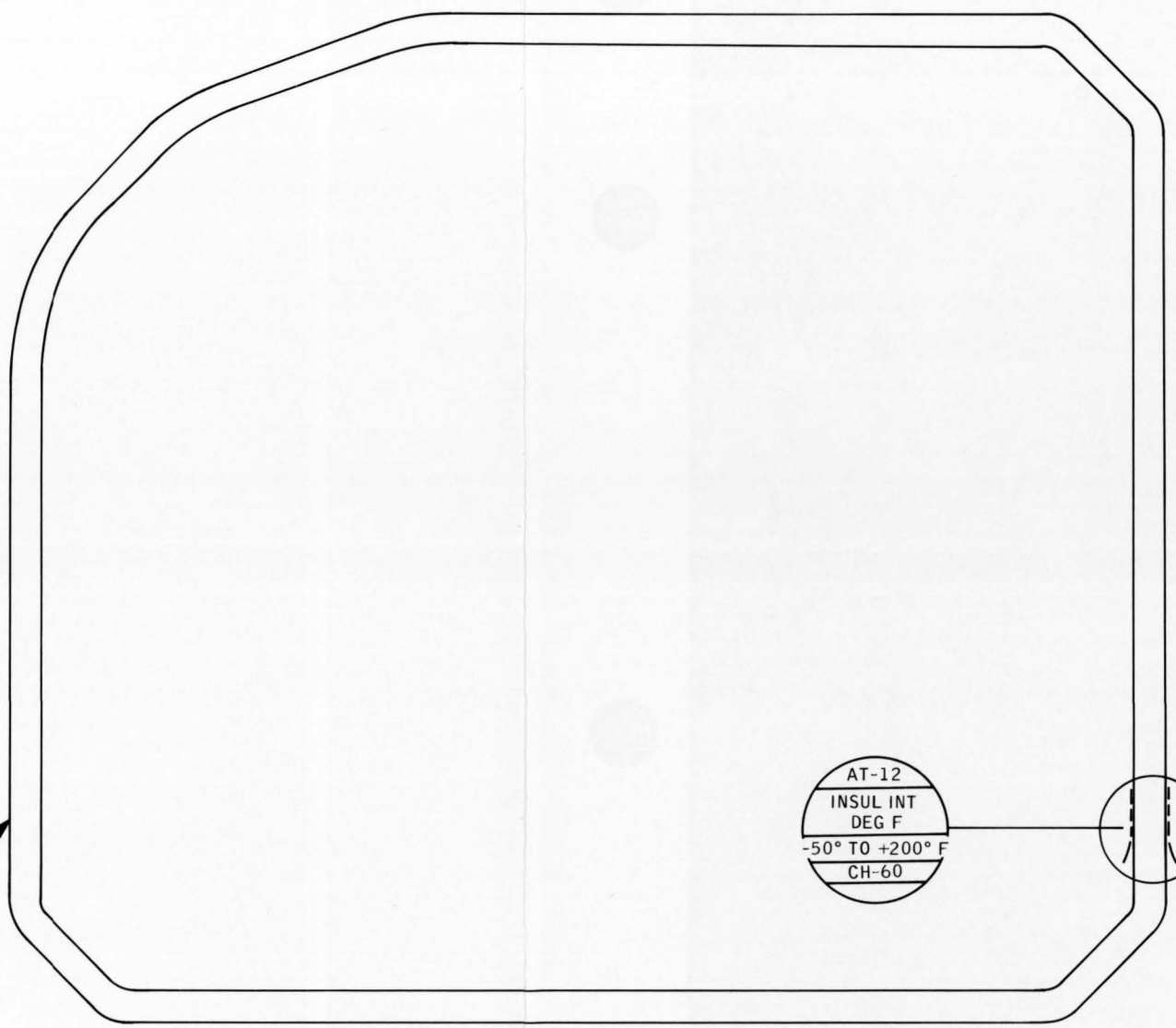

AT-13

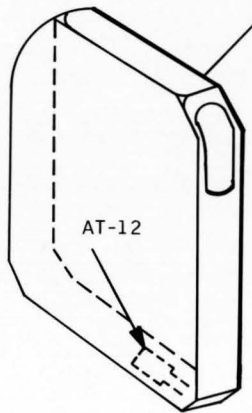
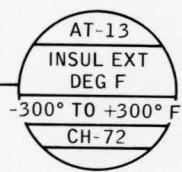

AT-12

THERMAL BAG

SIGNATURES		DATE	NATIONAL AERONAUTICS & SPACE ADMINISTRATION		
DR <i>G. Y. Fanto</i>		1/11/71	MANNED SPACECRAFT CENTER • HOUSTON, TEXAS		
DSGN			<b>THERMAL BAG</b>		
QC <i>Betty M. Taylor</i>		3/20/71			
ENGR <i>Paul Waring</i>		16 Mar 71			
APP <i>James E. Saulsby</i>		16 Mar 71			
FEC <i>Dean B. Reaka</i>		3/20/71	ALSEP A2	SIZE	DWG NO
				<b>C<sub>1</sub></b>	<b>3.4</b>
			22 X 17	PAGE 3-4	SHEET 1 OF 1

LTR	PCN	DR	ENGR	DATE	APPROVAL

COMMENTS:

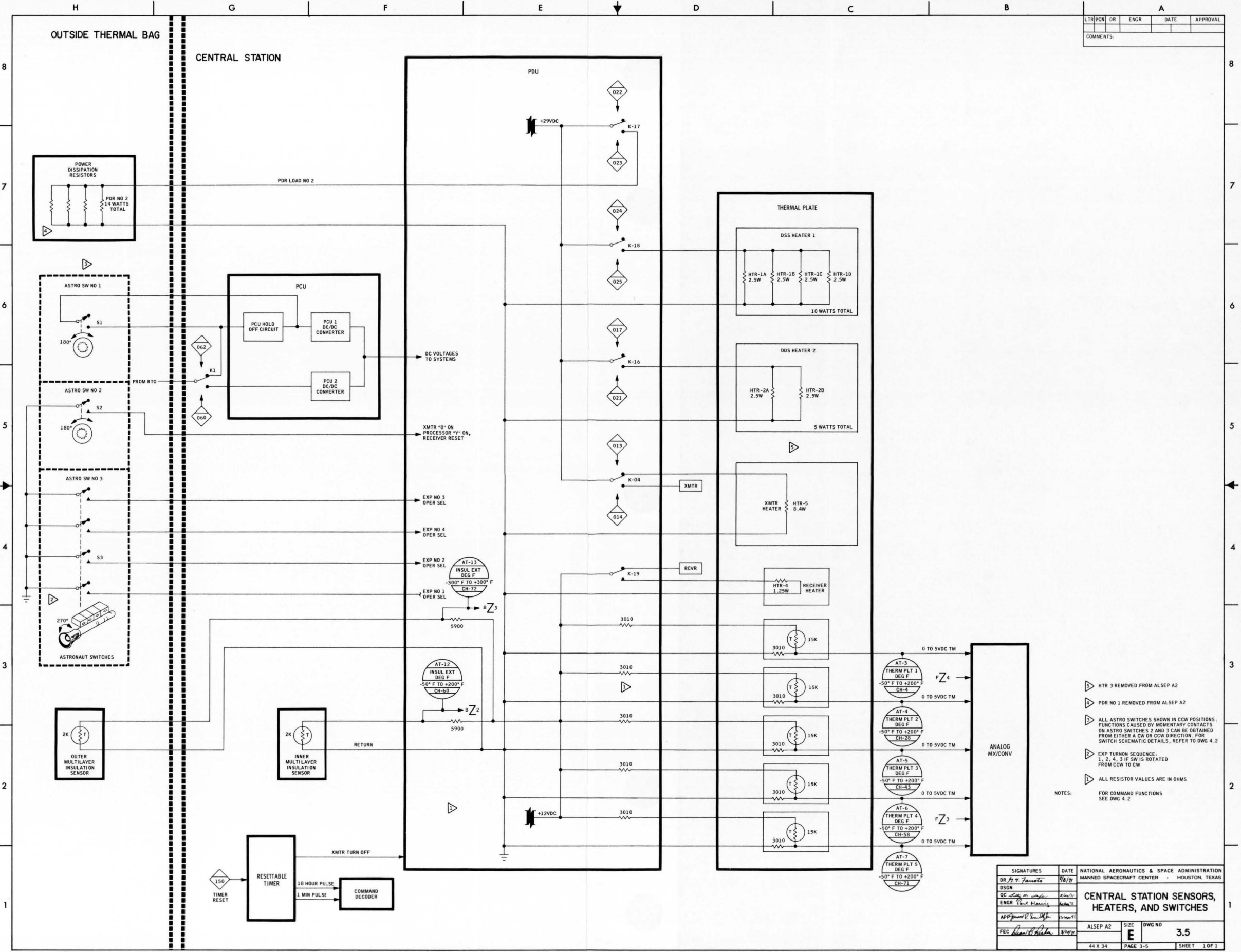

- NOTES:
- ▶ HTR 3 REMOVED FROM ALSEP A2
  - ▶ PDR NO 1 REMOVED FROM ALSEP A2
  - ▶ ALL ASTRO SWITCHES SHOWN IN CCW POSITIONS. FUNCTIONS CAUSED BY MOMENTARY CONTACTS ON ASTRO SWITCHES 2 AND 3 CAN BE OBTAINED FROM EITHER A CW OR CCW DIRECTION. FOR SWITCH SCHEMATIC DETAILS, REFER TO DWG 4.2
  - ▶ EXP TURNON SEQUENCE: 1, 2, 4, 3 IF SW IS ROTATED FROM CCW TO CW
  - ▶ ALL RESISTOR VALUES ARE IN OHMS
  - ▶ FOR COMMAND FUNCTIONS SEE DWG 4.2

SIGNATURES	DATE	NATIONAL AERONAUTICS & SPACE ADMINISTRATION MANNED SPACECRAFT CENTER - HOUSTON, TEXAS	
DR <i>P. Y. Farnella</i>	11/8/77	<b>CENTRAL STATION SENSORS, HEATERS, AND SWITCHES</b> ALSEP A2    SIZE <b>E</b> DWG NO <b>3.5</b> 44 X 34    PAGE 3-5    SHEET 1 OF 1	
DSGN			
QC <i>[Signature]</i>			
ENGR <i>[Signature]</i>			
APP <i>[Signature]</i>			
FEC <i>[Signature]</i>	11/8/77		

\*

## SECTION 4

### ELECTRICAL POWER SUBSYSTEM

#### 4.1 SYSTEM DESCRIPTION

The electrical power subsystem provides the electrical power for lunar surface operation of the ALSEP. Primary electrical power is developed by thermoelectric action with thermal energy supplied by a radioisotope source. The primary power is converted, regulated, and filtered to provide the six operating voltages for the ALSEP experiment and support subsystems.

The components are a radioisotope thermoelectric generator assembly, a fuel capsule assembly, a power conditioning unit, and a power distribution unit.

##### 4.1.1 Radioisotope Thermoelectric Generator (RTG)

- A. RTG commands - No command capability
- B. RTG telemetry - Six temperatures (refer to Drawing 4.1), one output voltage, and one output current (refer to Tables 6-VII and 6-IX)
- C. Output - 68 watts, nominal (refer to Figure 4-1)

##### 4.1.2 Power conditioning Unit (PCU)

The PCU performs three major functions:

- A. Voltage conversion
- B. Voltage regulation
- C. RTG protection

Each power conditioner consists of a dc-to-dc power converter (inverter and rectifiers), which converts the RTG 16-volt input to the six operating voltages, and a shunt current regulator to maintain the output voltages within approximately  $\pm 1$  percent. The input voltage is also regulated by this action by maintaining a constant load on the RTG. It is necessary to keep

\*

a constant load on the generator to prevent overheating of the thermocouples in the RTG.

The +16 volts from the RTG is applied through the switching circuit to the selected dc-to-dc converter, applying power to the inverter and completing the shunt regulation circuit. Applying power to the inverter permits it to supply ac power to the rectifiers that develop the dc voltages applied to the filters. The outputs from the filters are the six operating voltages applied to the data subsystem and experiments. Output and input voltages are regulated by feedback from the +12-volt output to the shunt regulator. The +12-volt feedback is also applied to the switching circuit for over or under voltage determination for automatic switching to the redundant inverter and regulator, if necessary. All the output voltages are regulated by the 12-volt feedback.

#### 4.1.3 Power Distribution Unit (PDU)

The PDU distributes power to experiment and central station subsystems and provides circuit overload protection and power switching of selected circuits. The PDU also provides signal conditioning of selected central station and RTG telemetry signals prior to input to the analog multiplexer for analog-to-digital conversion and subsequent data transmission to earth.

4.1.3.1 Power-off sequencer.- (Refer to Figure 4-2.) The power-off sequencer of the PDU detects minimum reserve power and sequentially turns to standby up to three preselected experiments to bring the reserve power within acceptable limits. The reserve power parameter is not downlinked as such, but is calculated from TM parameters AE-3 (PCU IN VOLTS) and AE-5 (PCU 1 SHUNT AMPS):

$$(AE-3) (AE-5) = \text{Reserve power}$$

\*

(AE-3) (AE-6), when PCU 2 is operational. The minimum reserve power is detected by monitoring the voltage across the shunt regulator transistor. This voltage is applied to an operational amplifier used as a level detector. An RC delay network is employed at the output of the level detector. The output of the delay is applied to a second level detector which drives the power-off sequencer logic. This arrangement turns on the power-off sequencer logic input gate when the reserve power/shunt current drops below the following levels:

- A. Reserve power/shunt current to start experiment turnoff (135-ms delay): \_\_\_\_\_ ± \_\_\_\_\_ watts (AE-3 assumed to be constant at 16.0 volts)
- B. SHUNT CURRENT (AE-5 or AE-6): \_\_\_\_\_ ± \_\_\_\_\_ amp

Experiment turnoff sequence, via the power-off sequencer, is as follows:

- A. Experiment 4 (SIDE/CCGE)
- B. Experiment 3 (SWS)
- C. Experiment 1 (PSE)

NOTE

Experiment 2 (LSM) and  
Experiment 5 (HFE) are not  
in the turnoff sequence.

The sequencer decoding gates are connected so that upon turn-on of the logic input gate, an output ground level signal is provided during the count between 1 and 9 milliseconds to the SIDE/CCGE power standby relay driver. This relay removes experiment operate power and applies power to the standby line. If the overload persists, the ground level signal supplied to the SIDE/CCGE standby line is removed and a ground level signal is applied to the SWS power standby command input



\*

during the next 8-millisecond period (when the count is between 9 and 17 milliseconds). If overloading persists, the sequencer could continue in the same manner until the passive seismic experiment (PSE) is in the standby mode. If, however, the overload is removed within the sequence, the counter will be reset in 2 milliseconds after a satisfactory power reserve signal is obtained, thus stopping the sequence. Note that the power-off sequencer action places the experiments to STBY ON from either an OPER ON condition or from a STBY OFF condition.

4.1.3.2 Temperature sensor circuit.- Operational amplifiers are used to amplify the resistive bridge outputs for the RTG hot and cold junction temperatures. The temperature sensors located on the RTG are platinum wire sensors (see Drawing 4.1). Bridge excitation is 12 Vdc on both the hot and cold frame temperature circuits.

Nickel wire temperature sensors are used in dividers to monitor exposed structural temperature, multilayer bag insulation temperatures, and sunshield temperatures. The circuit is a simple divider consisting of 12 Vdc supplied through 5900 ohms and the sensor to ground. The output analog signal is taken across the sensor, providing a linear response from  $-300^{\circ}$  to  $+300^{\circ}$  F. (Refer to Section 3 for sensor locations.)

Thermistor sensors are provided to monitor temperatures within the central station and subsystems. The sensor ranges are between  $-50^{\circ}$  and  $+200^{\circ}$  F (See Drawing 3.2).

4.1.3.3 Power control.- (Refer to Drawing 4.2.) Power control is provided by ground commands and/or astronaut switch functions causing the command lines to go to ground potential, thus actuating relay drivers and their associated relays.

\*  
Four transistorized relay drivers, magnetic latching relays, and one magnetic latching relay acting as an overload sensor (circuit breaker) perform the control and circuit protection function for each experiment. The experiment standby power line is fused at 500 mA. Three command inputs are provided for each experiment power control circuit:

- A. Experiment operate select
- B. Experiment standby select
- C. Experiment standby off

The three command inputs operate one or both of two power switching relays. One relay provides the selection of either standby power or operational power. The other interrupts the standby power line. The receipt of an experiment operate select command will transfer the relay to a position which provides power through the current sensing coil of the circuit breaker relay to the experiment electronics. A second command, standby off, operates the relay coil of the standby power interruption relay to open the circuit supplying power to the standby line. The standby select command, however, operates on both relays. The standby select command actuates both relays to the positions that supply power to the standby line. To place an experiment from operate to standby off, the standby select command must be executed prior to the standby off command.

Circuit breaker resetting is provided by internally generating a standby select command using the contacts of a current sensing relay. Should an overcurrent condition exist through the sensing coil in series with the experiment operational power line, the contacts of the sensing relay break the standby select command line and apply a ground signal to each of two relay drivers. One relay driver operates the power

\*

select relay to the standby power position. The other driver operates the standby power interruption relay to close the contacts supplying power to the standby power line. Operation of the standby power interruption relay provides power to the reset coil of the overload sensing relay thereby resetting its contacts to permit normal standby select command inputs.

Transmitter power control and overload protection uses two power control relays, four overload sensing relays, and associated relay drivers. Four commands are required:

- A. Transmitter on
- B. Transmitter off
- C. Transmitter A select
- D. Transmitter B select

The transmitter on and off commands operate the double-pole double-throw relay K-04, which switches both +12 Vdc and +29 Vdc to the transmitter select relay K-05. When the transmitter is off, +29 Vdc is switched to the 8.4-watt transmitter heater. Of either transmitter A or transmitter B +29 Vdc power line is overloaded, the contacts of the overload sensing relay transfer the transmitter select relay to supply power to the alternate transmitter. When power is transferred to the alternate transmitter, the circuit overload sensing relays are both reset and the normal command inputs are restored. Diplexer switching power, required only when transmitter B is selected, is obtained directly from the +12 Vdc transmitter B power line. Note that the transmitters do not use +12 Vdc.

The command receiver requires both +12 and -6 Vdc for operation. The -6 Vdc line is not provided with circuit protection. The +12 Vdc line is provided with overload protection which uses a magnetic latching circuit breaker relay. The circuit breaker will in turn actuate relay K-19 and therefore interrupt +12 Vdc.

\*

Since no redundancy of receivers exists, a reset pulse from the timer is supplied to the circuit breaker every 18 hours. If the receiver is tripped off, +12 Vdc is switched to the 1.25-watt receiver heater.

For data processor power control, redundant electronics are switched using standard magnetic latching relays. These relays are controlled by ground commands. Overload protection is not provided.

DSS heater 1, power dissipation resistor 2, and DSS heater 2 are switched off and on by ground command only.

Electronics for the DTREM (see Drawing 7.1) consist of the following three functional areas:

- A. Power switching
- B. Operational amplifiers
- C. Temperature measurement

The power switching function switches +12 and -12 Vdc power to the amplifiers upon receiving a ground command. The switching function consists of a command flip-flop and power switching circuits. Power protection is provided by fuses. Note that power switching does not affect the temperature measurements.

TABLE 4-I.- PCU OVER AND UNDER VOLTAGE

[Over and under voltage sensing circuit - an automatic switchover circuit in PCU 1 which operates when the +12 Vdc bus varies outside the following limits. The sensing circuit causes a switch from PCU 1 to PCU 2]

Sensing circuit	Voltage level	Time delay
Over voltage	+13 ± 0.25 Vdc	10 ms
Under voltage	+11 ± 0.25 Vdc	300 ms

TABLE 4-II.- POWER CALCULATIONS

<u>TM symbol</u>	<u>Resultant (watts)</u>
(AE-3)(AE-4)	= RTG output power
(AE-3)(AE-5)	= Reserve power PCU 1
(AE-3)(AE-6)	= Reserve power PCU 2
(RTG output power) - (Reserve power)	= PCU input power
(AE-3)(AE-5) - (AE-5) <sup>2</sup> (4.2 Ω)	= Internal reg 1 dissipation
(AE-3)(AE-6) - (AE-6) <sup>2</sup> (4.2 Ω)	= Internal reg 2 dissipation

TABLE 4-III.- PDU RELAY INITIAL CONDITIONS

[Initial condition is defined as the relay positions at time of activation on the lunar surface]

Relay	Function	Monitor	Initial condition
K-01	PCU select	AE-5	PCU 1 selected
K-02, K-03	D/P select	AB-6	D/P X selected
K-04	Xmtr, xmtr htr select	Downlink	Xmtr on
K-05	Xmtr A, xmtr B select	AE-17	Xmtr A selected
K-06, K-07	Exp 1 power control	AB-4	Exp 1 in stby
K-08, K-09	Exp 2 power control	AB-4	Exp 2 in stby <sup>a</sup>
K-10, K-11	Exp 3 power control	AB-5	Exp 3 in stby
K-12, K-13	Exp 4 power control	AB-5	Exp 4 in stby
K-14, K-15	Exp 5 power control	AB-5	Exp 5 in stby
K-16	DSS heater 2 on/off	AE-5	Off
K-17	PDR 2 on/off	AE-5	Off
K-18	DSS heater 1 on/off	AE-5	Off
K-19	Receiver protection	Command capability	Receiver on

<sup>a</sup>Exp 2 (LSM) has no standby heater.

D

C

B

A

4

4

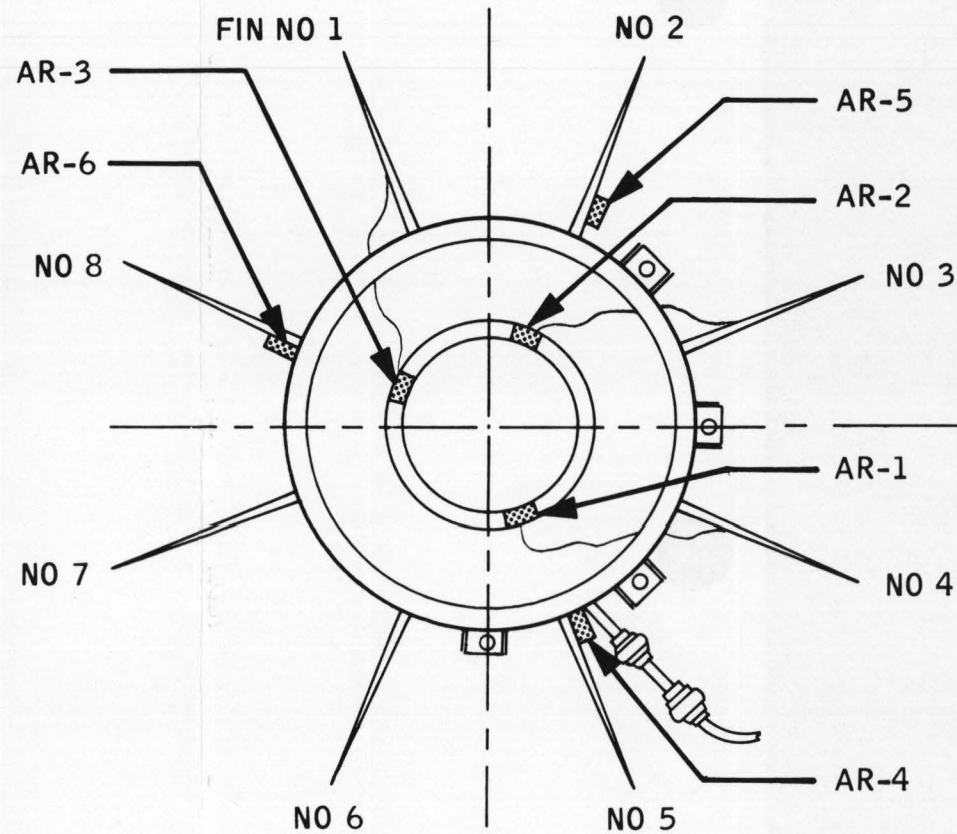

TOP VIEW

TM DESIGNATIONS

- AR-1 HOT FRAME 1
- AR-2 HOT FRAME 2
- AR-3 HOT FRAME 3
- AR-4 COLD FRAME 1
- AR-5 COLD FRAME 2
- AR-6 COLD FRAME 3

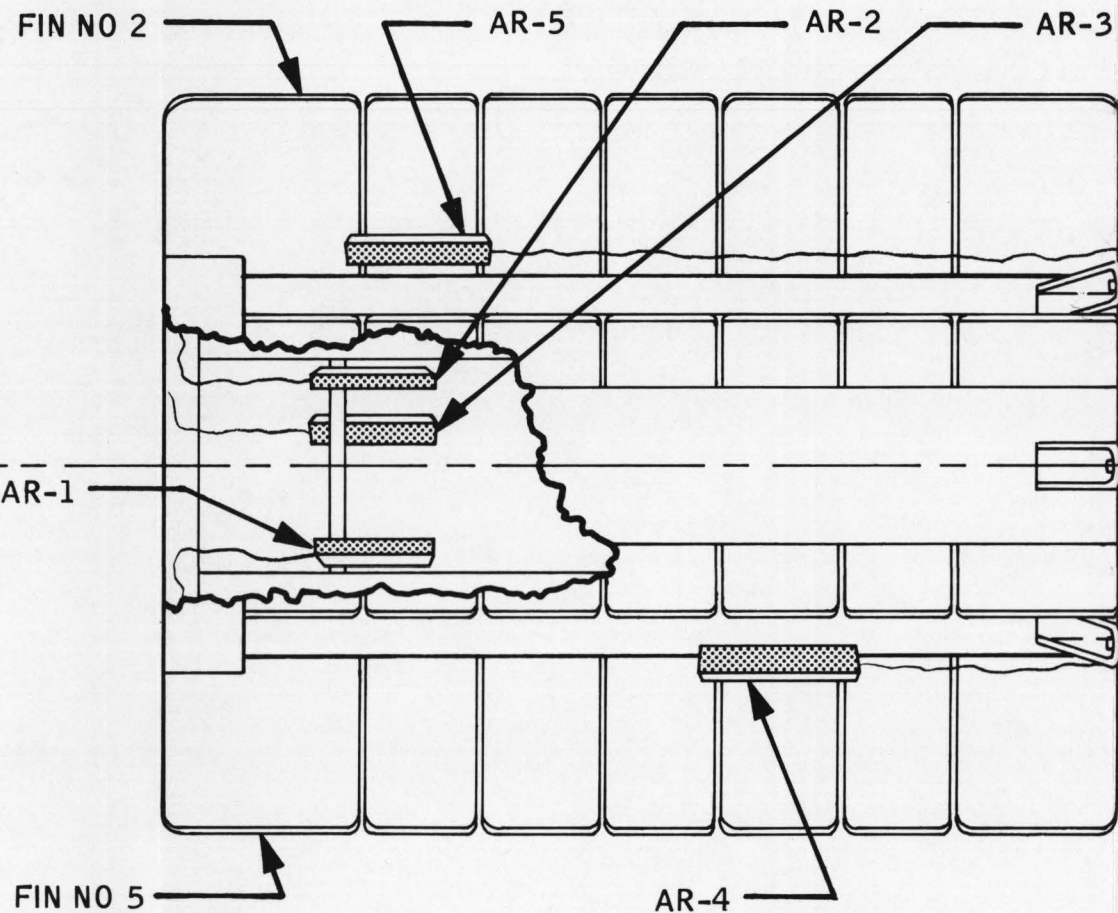

SIDE VIEW

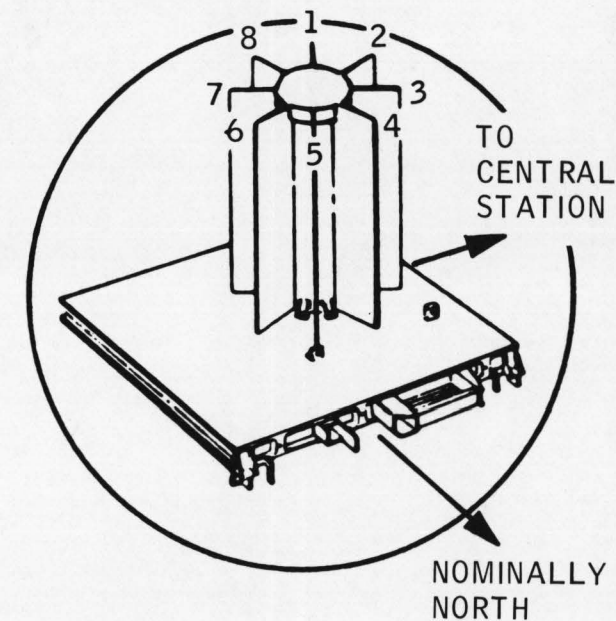

2

2

3

3

4

4

1

1

SIGNATURES		DATE	NATIONAL AERONAUTICS & SPACE ADMINISTRATION	
DR <i>Malcolm E. Smith</i>		1-25-71	MANNED SPACECRAFT CENTER • HOUSTON, TEXAS	
DSGN			RTG TEMPERATURE SENSOR LOCATIONS	
QC <i>Betty M. Taylor</i>		3/19/71		
ENGR <i>Paul Nering</i>		1/6/71		
APP <i>James E. Saulsby</i>		1/6/71		
FEC <i>Dean B. Ruelow</i>		3/20/71	ALSEP A2	SIZE DWG NO.
			<b>B<sub>1</sub></b>	4.1
			10.5 X 17	PAGE 4-10 SHEET 1 OF 1





4-12

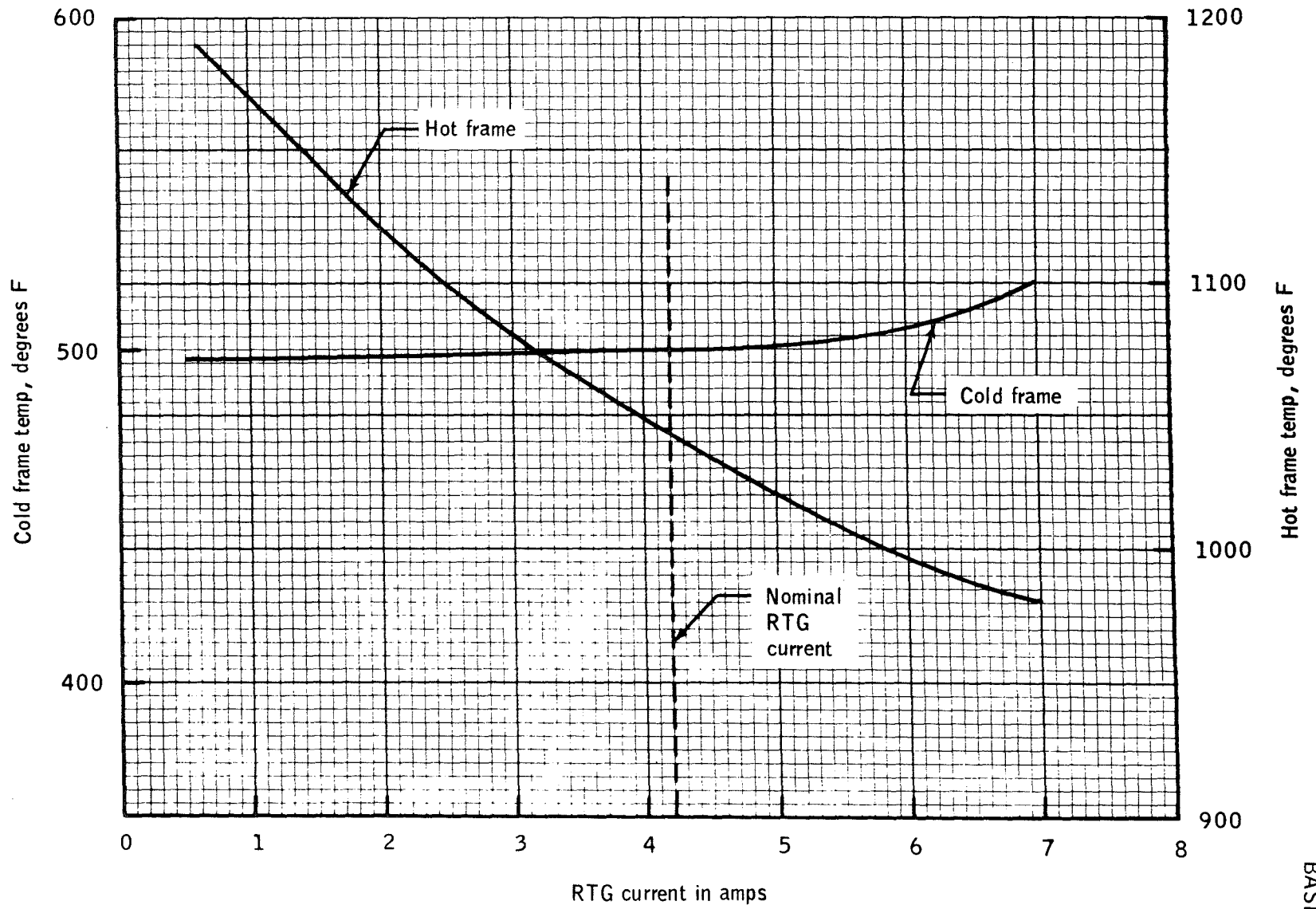

Figure 4-2. - RTG hot and cold frame temps vs RTG current.

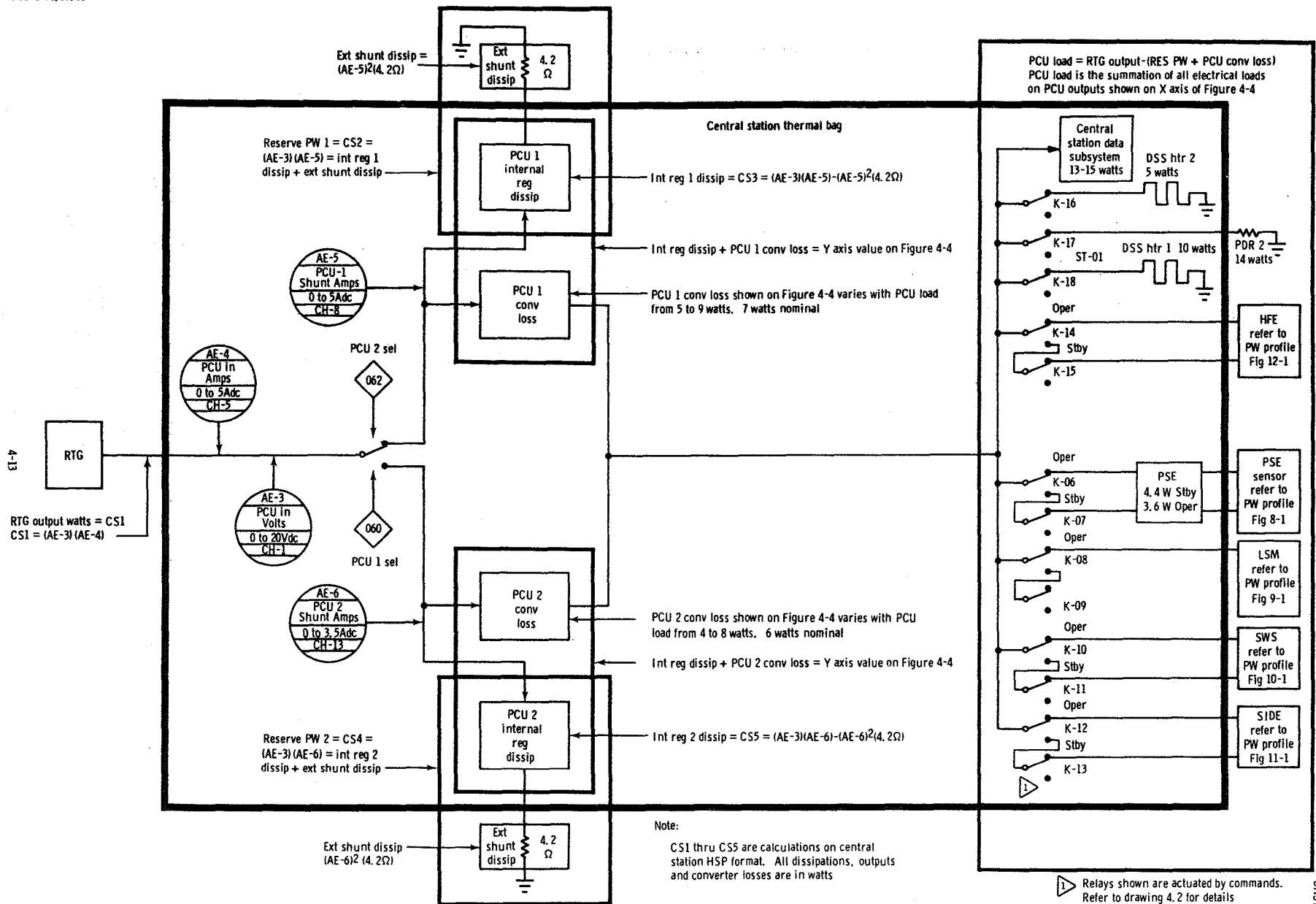

Figure 4-3. - Power dissipation distribution.

Dissipation within PCU vs PCU output power  
55 watt regulator

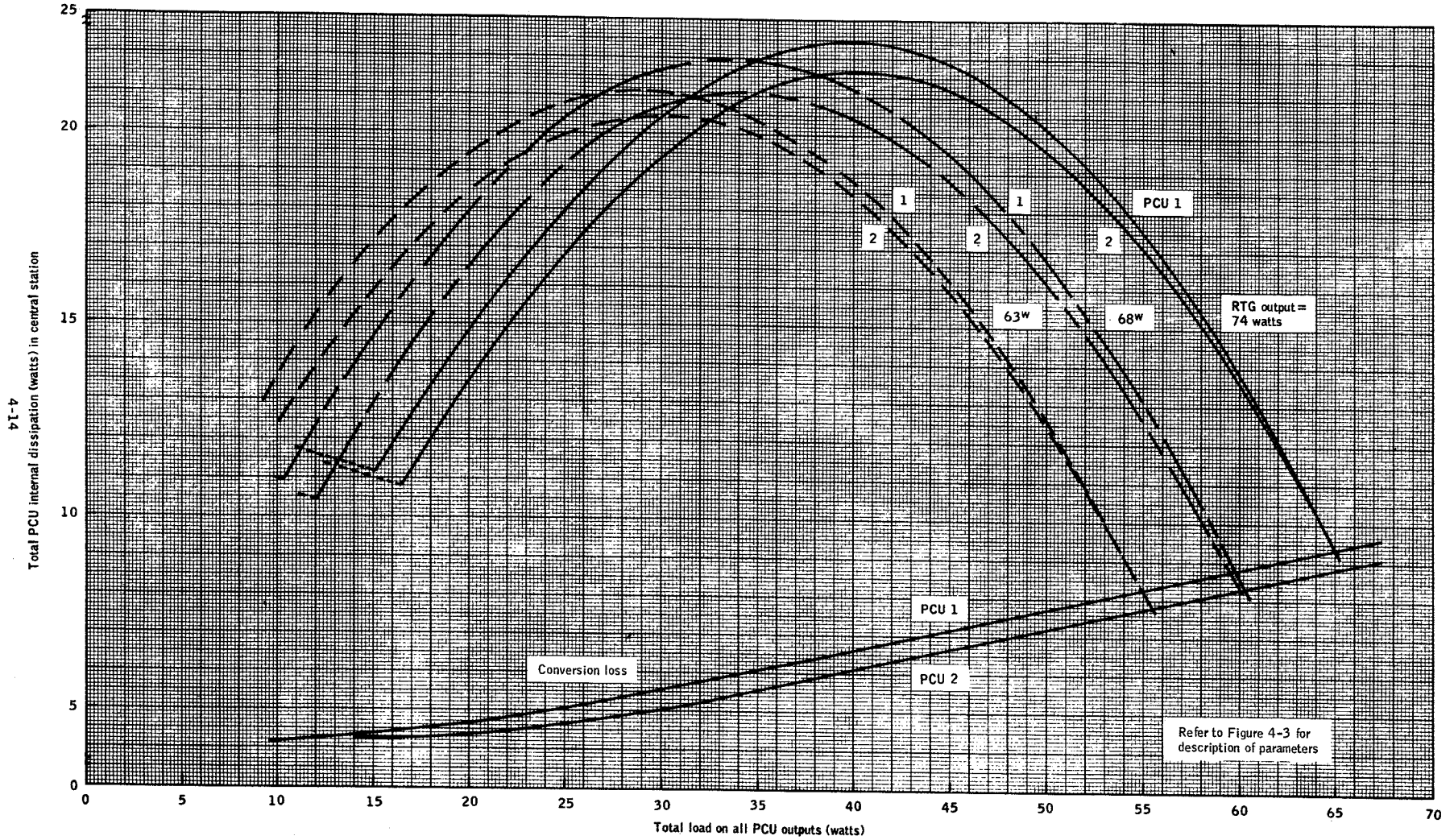

Figure 4-4. - PCU load vs RTG power output vs central station dissipation.

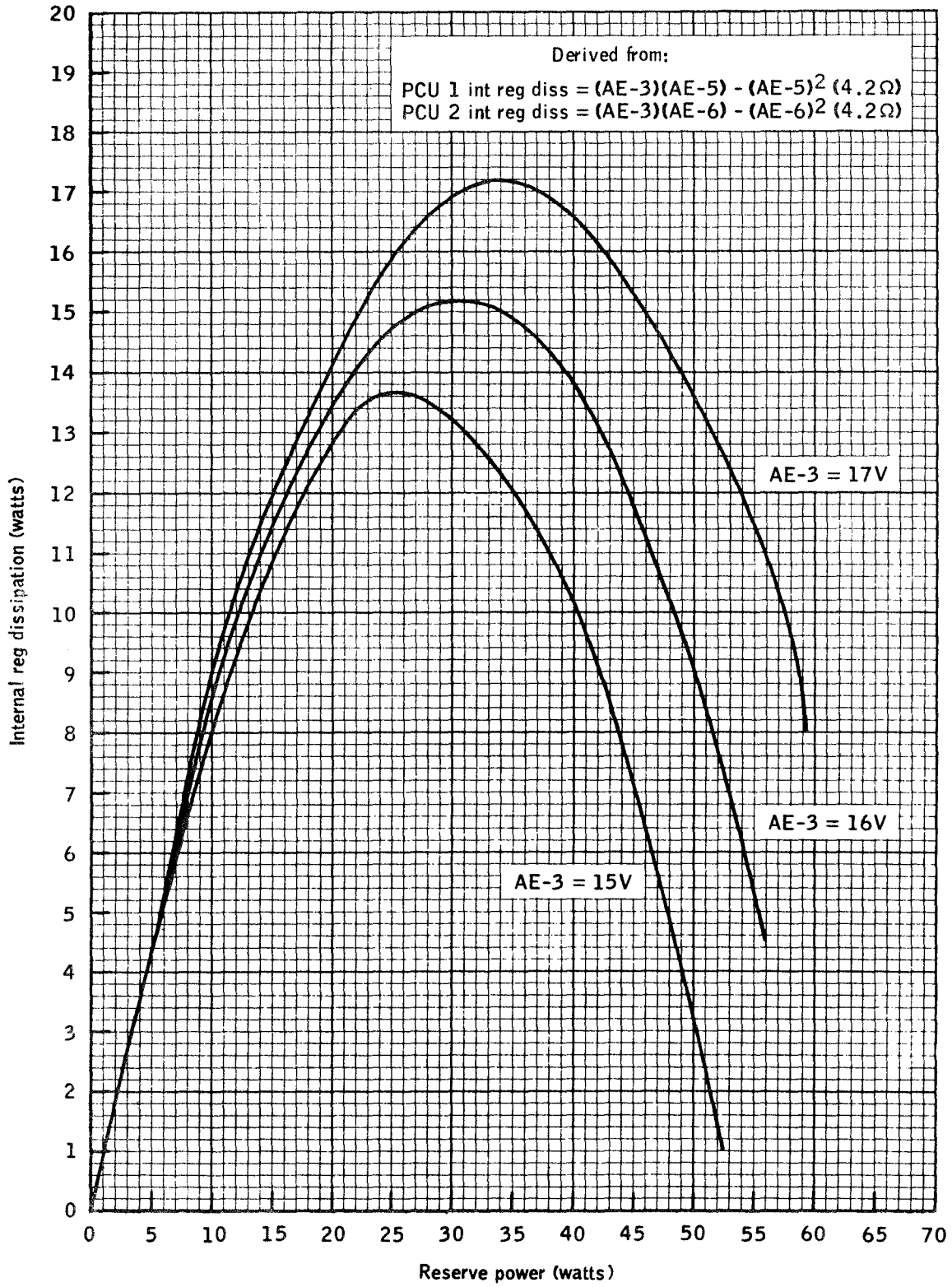

Figure 4-5. - Internal regulator dissipation.

TABLE 4-IV.- CIRCUIT BREAKER AND FUSE TABULATION

Number	Rating	Subsystem	Circuit	Effect
CB-01	110 to 225 mA	Command receiver	+12 Vdc	Receiver overload causes breaker CB-01 to switch in 1.25-watt receiver heater. No protection for heater. Breaker reset by 18-hour timer pulse.
CB-02	110 to 225 mA	Transmitter A	+12 Vdc	The A2 transmitter A does not utilize the +12 Vdc bus. Breaker CB-02 is self-resetting.
CB-03	560 to 840 mA	Transmitter A	+29 Vdc	Transmitter A +29 Vdc overload causes breaker CB-03 to switch transmitter B on. Breaker CB-03 is self-resetting.
CB-04	110 to 225 mA	Transmitter B	+12 Vdc	The A2 transmitter B does not utilize the +12 Vdc bus. +12 Vdc is applied to the diplexer switch via CB-04 when transmitter B is selected. Breaker CB-04 is self-resetting.
CB-05	560 to 840 mA	Transmitter B	+29 Vdc	Transmitter B +29 Vdc overload causes breaker CB-05 to switch transmitter A on. Breaker CB-05 is self-resetting.
CB-06	450 to 550 mA	PSE operate	+29 Vdc	PSE instrument overload causes breaker CB-06 to place PSE in standby. Breaker CB-06 is self-resetting.
CB-07	450 to 550 mA	LSM operate	+29 Vdc	LSM instrument overload causes breaker CB-07 to place LSM to off. <u>NOTE:</u> LSM has no standby heater. Breaker CB-07 is self-resetting.
CB-08	450 to 550 mA	SWS operate	+29 Vdc	SWS instrument overload causes breaker CB-08 to place SWS in standby. Breaker CB-08 is self-resetting.
CB-09	450 to 550 mA	SIDE/CCGE operate	+29 Vdc	SIDE/CCGE instrument overload causes breaker CB-09 to place SIDE/CCGE in standby. Breaker CB-09 is self-resetting.
CB-10	450 to 550 mA	HFE operate	+29 Vdc	HFE instrument overload causes breaker CB-10 to place HFE in standby. Breaker CB-10 is self-resetting.
F-01	250 mA	DTREM	-12 Vdc	A blown fuse F-01 will permanently disable the DTREM, resulting in loss of photoelectric cell voltage TM parameters AX-4, AX-5, and AX-6.
F-02	250 mA	DTREM	+12 Vdc	A blown fuse F-02 will permanently disable the DTREM, resulting in loss of photoelectric cell voltage TM parameters AX-4, AX-5, and AX-6 and photoelectric cell temp TM parameters AX-1, AX-2, and AX-3.
F-03	500 mA	PSE standby	+29 Vdc	A blown F-03 will permanently disable the PSE standby capability.
F-04	500 mA	LSM standby	+29 Vdc	A blown F-04 will only affect TM parameter AB-4. Refer to Drawing 4.2.
F-05	500 mA	SWS standby	+29 Vdc	A blown F-05 will permanently disable the SWS standby capability.
F-06	500 mA	SIDE/CCGE standby	+29 Vdc	A blown F-06 will permanently disable the SIDE/CCGE standby capability.
F-07	500 mA	HFE standby	+29 Vdc	A blown F-07 will permanently disable the HFE standby capability.
F-08	1/32 A	Transmitter A	+29 Vdc	A blown F-08 will permanently disable all TM parameters from transmitter A.
F-09	1/32 A	Transmitter B	+29 Vdc	A blown F-09 will permanently disable all TM parameters from transmitter B.

TABLE 4-V. VOLTAGE DISTRIBUTION AND BUS LOAD ANALYSIS

NOTE

Experiment operational power is defined as maximum nighttime steady state (e.g., PSE oper). Experiment standby power is defined as maximum heater power (e.g., PSE stby). The voltage distribution and load analysis represent measurements at an ambient temperature of 70° F.

Voltage bus	Circuit	Watts	mAdc	Circuit protection <sup>a</sup>
+29 Vdc	PSE Oper	10.2	353	CB-06 500 mA ± 10%
	Stby	5.0	173	F-03 500 mA
	LSM Oper			CB-07 500 mA ± 10%
	Stby	0.0	0	F-04 500 mA
	(No htr)			
	SWS Oper	6.2	215	CB-08 500 mA ± 10%
	Stby	4.0	138	F-05 500 mA
	SIDE Oper	10.5	360	CB-09 500 mA ± 10%
	Stby	6.0	206	F-06 500 mA
	HFE Oper	10.0	345	CB-10 500 mA ± 10%
	Stby	4.2	145	F-07 500 mA
	Xmtr A	10.0 <sup>b</sup> -10.8 <sup>c</sup>	345-375	CB-03 560 to 840 mA
	Xmtr B	10.0 <sup>b</sup> -10.8 <sup>c</sup>	345-375	CB-05 560 to 840 mA
	Xmtr htr	8.4		None
	DSS htr 1	10.0		None
DSS htr 2	5.0		None	
PDR 2	14.0		None	
PDU	0.5		None	
+15 Vdc	DSS/A	0.05		None
+12 Vdc	Cmd dec	0.325		None
	Timer	0.24		None
	Diplexer sw	0.1	8.5	CB-04 110 to 225 mA
	DSS/A	0.14		None
	DDS/D	0.05		None
	DTREM	0.15	12.5	F-02 250 mA
	PCU	Negligible		None
	PDU	1.15		None
	Receiver	0.79	66	CB-01 110 to 225 mA
	Revtr htr	1.25		None
Temp sensors	Negligible		None	
+5 Vdc	Cmd dec	0.775		None
	DSS/A	1.10		None
	DSS/D	0.450		None
	PDU	0.15		None
	Relay drivers	Negligible		None
-6 Vdc	Cmd dec	0.15		None
	PDU	Negligible		None
	Receiver	0.030		None
-12 Vdc	DSS/A	0.11		None
	DTREM	0.1	8.5	F-01 250 mA
	PDU	0.6		None

<sup>a</sup>Ref Drawing 4.2.

<sup>b</sup>At -10° F.

<sup>c</sup>At +140° F.

TABLE 4-VI.- COMMANDS CAUSING DELTA POWER DEMANDS

Tabulation of  $\Delta P$  caused by command execution assuming the following conditions exist:

The ALSEP subsystems will demand electrical power from the PCU in the following amounts:

Transmitter	Off		
DSS heater 1	Off		
PDR 2	Off		
DSS heater 2	Off		
DTREM	Off		
PSE	Off		
LSM	Off		
SWS	Off		
SIDE/CCGE	Off		
HFE	Off		

		<u>Power (watts)</u>
Transmitter heater		8.40
Receiver		0.82
DSS/D		0.50
DSS/A		1.40
Cmd decoder		1.25
PDU		1.40
Timer		0.24
PCU conversion loss		<u>4.50</u>
Total		18.51

The 18.51 watts represents the minimum loading on the PCU. Add the delta power of any of the following commands to obtain total loading. PCU conversion losses increase with loading. For detailed experiment power demands, refer to experiment power profiles.

<u>Command</u>	<u>Delta power (watts)</u>	<u>Notes</u>
013 TRANSMITTER ON	2.4 2.5	Xmtr A selected by Cmd 012. Xmtr B selected by Cmd 015.
017 DSS HTR 2 ON	5.0	
022 PDR 2 ON	14.0	
024 DSS HEATER 1 ON	10.0	Thermostatically controlled.
027 DTREM ON	0.25	
036 EXP 1 OPER SEL (PSE)	4.4 10.1	Day scientific mode. Above +127° F. Night scientific mode. Below +125° F. (5.70-watt difference due to heater. See Cmd 076). Turn on transient.
037 EXP 1 STBY SEL (PSE)	5.0	Survival heaters.
042 EXP 2 OPER SEL (LSM)	5.5 10.5	Day scientific mode. Above +35° C. Night scientific mode. Below +35° C. (5-watt difference due to heaters. See Cmd 134.) Turn on transient.
043 EXP 2 STBY SEL (LSM)	0.0	No survival heaters in the LSM.
045 EXP 3 OPER SEL (SWS)	6.2 6.5	Day scientific mode. Night scientific mode. (0.3-watt difference due to heaters.) Turn on transient.
046 EXP 3 STBY SEL (SWS)	4.0	Survival heaters.
052 EXP 4 OPER SEL (SIDE/CCGE)	6.5 10.5	Day scientific mode. Night scientific mode. (4.0-watt difference due to thermostatically controlled heater.) Turn on transient.
053 EXP 4 STBY SEL	6.0 2.0	Survival heater. Below 0° C. Survival heater. Above 0° C.
055 EXP 5 OPER SEL (HFE)		
056 EXP 5 STBY SEL (HFE)	4.2	Survival heater.
070 LEVEL POWER X MOTOR (PSE)	3.0	Above PSE operate power (see Cmd 036). Exp 1 (PSE) must be operational.
071 LEVEL POWER Y MOTOR (PSE)		Same as Cmd 070.
072 LEVEL POWER Z MOTOR (PSE)		Same as Cmd 070.

TABLE 4-VI.- COMMANDS CAUSING DELTA POWER DEMAND - Concluded

<u>Command</u>	<u>Delta power (watts)</u>	<u>Notes</u>
C76 THERMAL CONTROL MODE (PSE)		
AUTO	0.04 to 5.7	Proportional heater (127° to 125° F).
FORCED	5.8	Heater on.
OFF	0.0	Heater off. Exp 1 (PSE) must be operational.
107 AND 110 REMOVE DUST COVER (SIDE)	6.0	Transient for 2.5 seconds. Remove dust cover one time function (day only). Exp 4 (SIDE) must be operational.
122 SWS DUST COVER REMOVAL	5.5	Transient for 4.0 seconds. Dust cover removal one time function (day only). Exp 3 (SWS) must be operational.
131 FLIP/CAL INITIATE (LSM)	3.4 (day) 1.0 (night)	Exp 2 (LSM) must be operational. Heaters switched off during flip-cal sequence. (1.0-watt above nominal night power demand of 10.9 watts.)
133 SITE SURVEY (LSM)	4.5	Day only. Exp 2 (LSM) must be operational.
134 TEMP CONTROL (LSM) X OR Y	5.0	Thermostatically controlled heaters.
OFF	0.0	Heaters off. Exp 2 (LSM) must be operational.

NOTE

PCU conversion loss (4.5-watt at  
minimum PCU loading) or shunt  
regulator dissipation not included.  
Conversion loss and shunt regulator  
dissipation dependent on PCU  
loading. Refer to Figures 4-4  
and 4-5.



ALSEP A2  
BASIC

TABLE 4-VII.- CENTRAL STATION STEADY STATE POWER DEMANDS ON EACH VOLTAGE BUS FROM THE PCU

Subsystem	+29 Vdc	+15 Vdc	+12 Vdc	-12 Vdc	-6 Vdc	+5 Vdc	Total	Notes
Xmtr A	10.0 W <sup>a</sup> 10.8 W <sup>a</sup>						10.0 W (+10°F) 10.8 W (+140°F)	Cmd 012 selects A xmtr. Xmtr A protection: +29 Vdc CB-03. Cmd 015 selects B xmtr. Xmtr B protection: +29 Vdc CB-05.
Xmtr B	10.0 W <sup>a</sup> 10.8 W <sup>a</sup>		0.1 W				10.0 W (-10°F) 10.8 W (+140°F)	Cmd 013 turns on selected xmtr. Cmd 014 turns off selected xmtr. Overload on +29 Vdc bus (560 to 840 mA) causes a switch to other xmtr. When xmtr is commanded off (Cmd 014) xmtr heater is automatically turned on. The +12 Vdc bus is switched to diplexer when xmtr B is operational.
Xmtr Heater	8.4 W						8.4 W	
Receiver			0.79 W		0.03 W		0.82 W	No ground commands to control receiver. Overload on +12 Vdc bus (110 to 225 mA) disconnects +12 Vdc (via CB-01) from receiver and switches in receiver heater. Receiver is turned back on by 18-hour pulse from timer. -6 Vdc on continuously.
Receiver heater			1.25 W				1.25 W	
X or Y data processor			0.05 W			0.45 W	0.50 W	Cmd 034 selects X data proc, mux, and A/D converter.
X or Y analog mux & A/D conv		0.05 W	0.14 W	0.11 W		1.10 W	1.4 W	Cmd 035 selects Y data proc, mux, and A/D converter. No overload protection.
Command decoder			0.325 W		0.15 W	0.775 W	1.25 W	Command decoder is on continuously with no overload protection. Redundant decoders A and B addressable from ground.
PDU	0.5 W		1.15 W	0.6 W	0.008 W	0.15 W	2.4 W	PDU controls distribution of power to the ALSEP subsystems. +12, -12, and +5 Vdc are for power sequencer logic. +29 and +5 Vdc are used for relay drivers located in PDU.
DTREM			0.153 W	0.100 W			0.253 W	Cmd 027 turns DTREM on. +12 Vdc bus fuse F-01. -12 Vdc bus fuse F-02. 250 mA each. Cmd 031 turns DTREM off. DTREM temps on continuously.
PCU 1 or PCU 2							4.5 to 8.5 W	Cmd 060 turns on PCU 1, PCU 2 off. Cmd 062 turns on PCU 2, PCU 1 off. Conversion loss is a function of loading on the PCU. See Figure 4-4.
DSS heater 2	5.0 W						5.0 W	Cmd 017 turns on DSS heater 2. Cmd 021 turns off DSS heater 2.
PDR 2	14.0 W						14.0 W	Cmd 022 turns on PDR 2. Cmd 023 turns off PDR 2. PDR 2 is located on the PDM and is exposed to the lunar environment. See Dwg 3.3.
DSS heater 1	10.0 W						10.0 W	Cmd 024 turns DSS heater 1 on. Cmd 025 turns DSS heater 1 off.

<sup>a</sup>Transmitter power demand varies with temperature at AT-24 or AT-26.

TABLE 4-VIII.- RELAY DRIVER FUNCTIONS AND INPUT VOLTAGE REQUIREMENTS

Relay drivers	Relay	Function	Monitor	Cmd	+12 Vdc	Input voltage			+29 Vdc
						(A)	(B)	(C)	
RD-01	K-01	PCU 1 SEL	AE-5	060	X				
02	K-01	PCU 2 SEL	AE-6	062	X				
03	K-06	EXP 1 OPER SEL	*	036			X		X
04	K-06	EXP 1 STBY SEL	AB-4	037			X	X	
05	K-07	EXP 1 STBY SEL	AB-4	037			X	X	
06	K-07	EXP 1 STBY OFF	*	041			X	X	
07	K-08	EXP 2 OPER SEL	*	042			X		X
08	K-08	EXP 2 STBY SEL	AB-4	043			X	X	
09	K-09	EXP 2 STBY SEL	AB-4	043			X	X	
10	K-09	EXP 2 STBY OFF	*	044			X	X	
11	K-10	EXP 3 OPER SEL	*	045			X		X
12	K-10	EXP 3 STBY SEL	AB-5	046			X	X	
13	K-11	EXP 3 STBY SEL	AB-5	046			X	X	
14	K-11	EXP 3 STBY OFF	*	050			X	X	
15	K-12	EXP 4 OPER SEL	*	052			X		X
16	K-12	EXP 4 STBY SEL	AB-5	053			X	X	
17	K-13	EXP 4 STBY SEL	AB-5	053			X	X	
18	K-13	EXP 4 STBY OFF	*	054			X	X	
19	K-14	EXP 5 OPER SEL	*	055			X		X
20	K-14	EXP 5 STBY SEL	AB-5	056			X	X	
21	K-15	EXP 5 STBY SEL	AB-5	056			X	X	
22	K-15	EXP 5 STBY OFF	*	057			X	X	
23	CB-01	RECEIVER RESET		18 hr pulse			X	X	
24	K-02	DSS/PROC Y SEL	AB-6	035			X	X	
25	K-03	DSS/PROC X SEL	AB-6	034			X	X	
26	K-04	XMTR OFF		014		X			X
27	K-04	XMTR ON		013		X			X
28	K-05	XMTR A SEL	AE-17	012			X	X	
29	K-05	XMTR B SEL	AE-18	015			X	X	
30	K-18	DSS HTR 1 ON	*	024		X			X
31	K-18	DSS HTR 1 OFF	*	025		X			X
32	K-16	DSS HTR 2 ON	*	017		X			X
33	K-16	DSS HTR 2 OFF	*	021		X			X
34	K-17	DISSIP R2 ON	*	022		X			X
35	K-17	DISSIP R2 OFF	*	023		X			X

\*Function determined by monitoring PCU 1 shunt current AE-5, or PCU 2 shunt current AE-6.

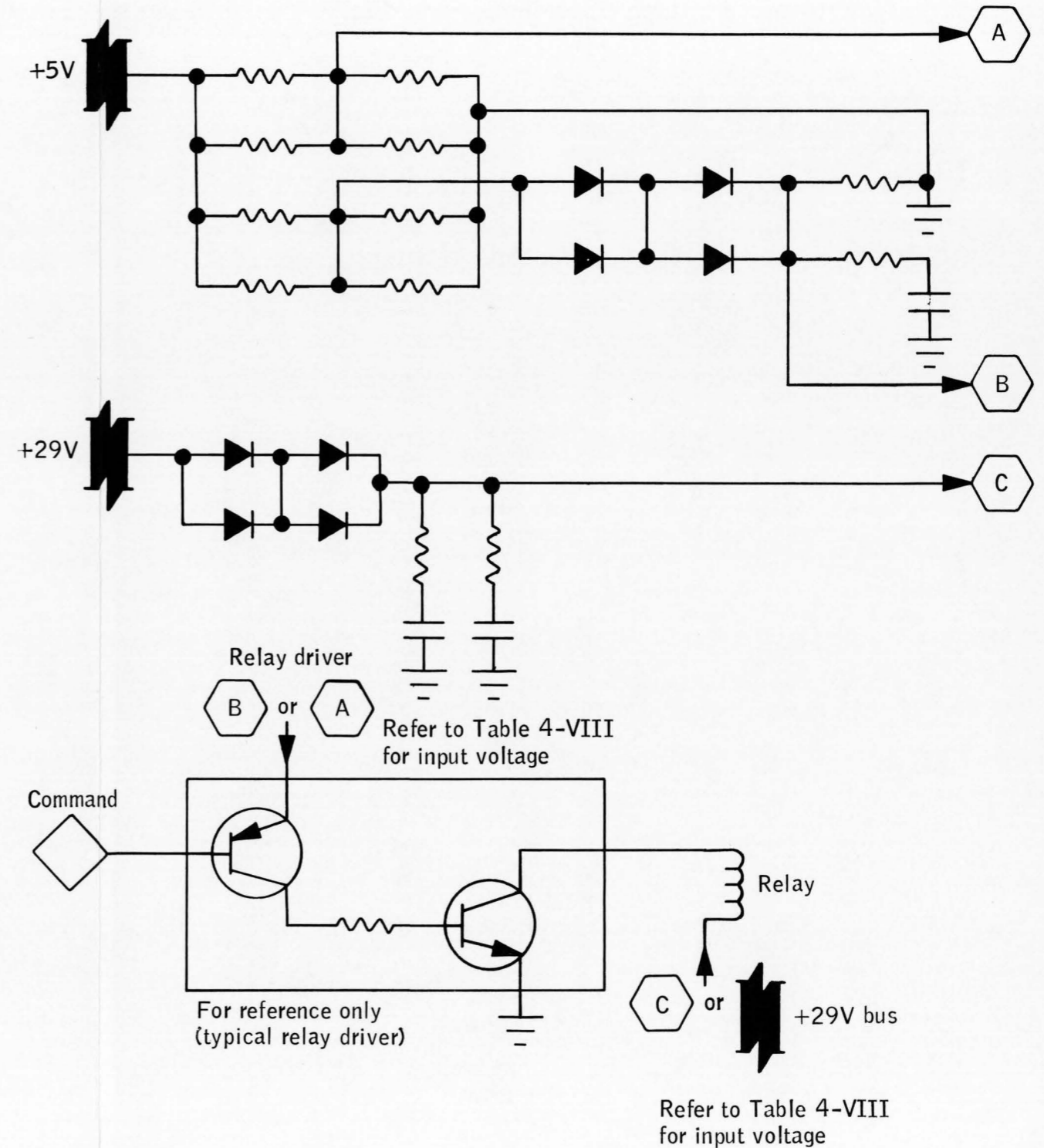
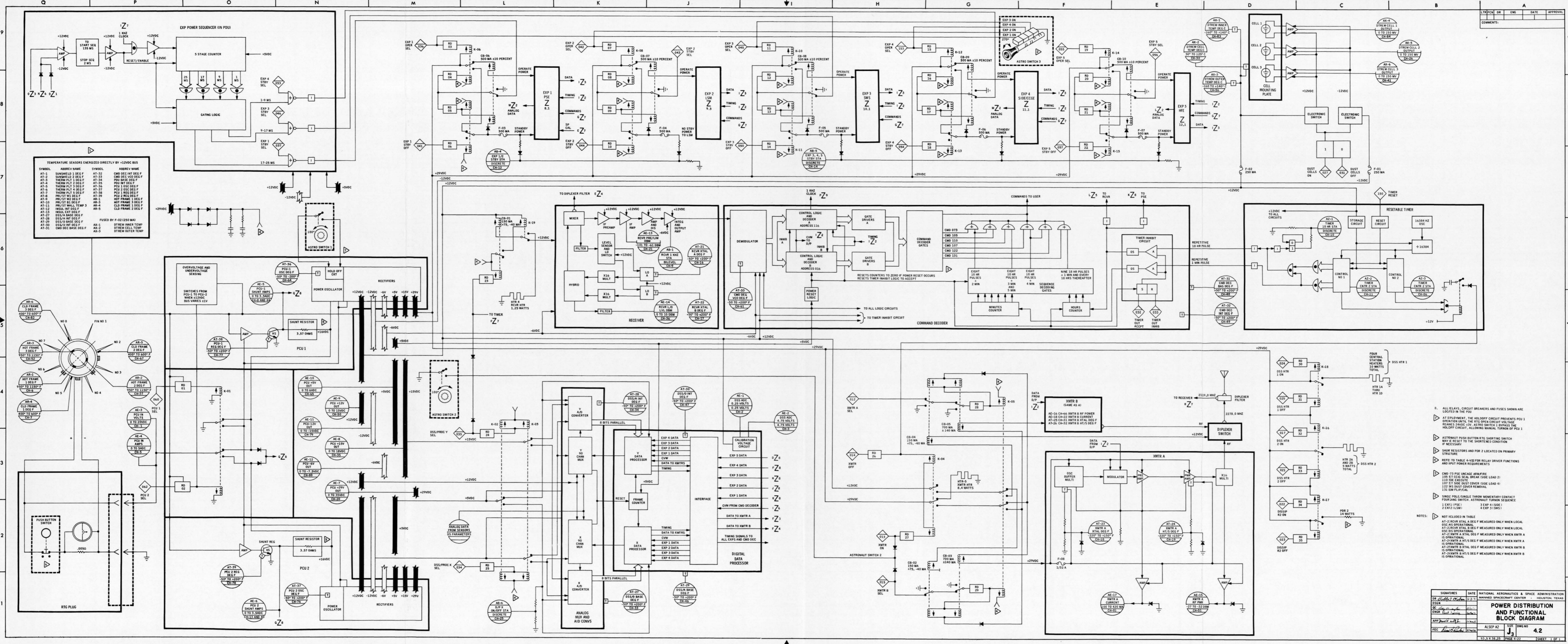

Figure 4-6. - Relay driver voltages .



TEMPERATURE SENSORS ENERGIZED DIRECTLY BY +12VDC BUS

SYMBOL	ABBREV NAME	SYMBOL	ABBREV NAME
AT-1	SUNSHIELD 1 DEG F	AT-27	DSS/A BASE DEG F
AT-2	SUNSHIELD 2 DEG F	AT-28	DSS/A INT DEG F
AT-3	CMD DEC VDD DEG F	AT-29	DSS/O BASE DEG F
AT-4	THERM PLT 1 DEG F	AT-30	DSS/O INT DEG F
AT-5	THERM PLT 2 DEG F	AT-31	CMD DEC BASE DEG F
AT-6	THERM PLT 3 DEG F		
AT-7	THERM PLT 4 DEG F		
AT-8	THERM PLT 5 DEG F		
AT-9	PRV/ST W3 DEG F		
AT-10	PRV/ST W2 DEG F		
AT-11	PRV/ST WALL TEMP 3		
AT-12	INSUL INT DEG F		
AT-13	INSUL INT DEG F		
AT-14	DSS/A BASE DEG F		
AT-15	DSS/A INT DEG F		
AT-16	DSS/O BASE DEG F		
AT-17	DSS/O INT DEG F		

8. ALL RELAYS, CIRCUIT BREAKERS AND FUSES ARE LOCATED IN THE PDU
- AT-1: EQUIPMENT THE HOLD-OFF CIRCUIT PREVENTS PCU 1 OPERATION UNTIL THE RTG OPERA CIRCUIT VOLTAGE REACHES 28VDC. AS THE SWITCH BYPASS THE HOLD-OFF CIRCUIT, ALLOWING MANUAL TURN ON OF PCU 1
- ASTRONAUT PUSH BUTTONS: SHOOTING SWITCH MAY BE RESET TO THE SHORT-TRIP CONDITION IF NECESSARY
- MINI RESISTORS AND PWR 2 LOCATED ON PRIMARY STRUCTURE
- REFER TO TABLE 4-2 FOR RELAY DRIVER FUNCTIONS AND INPUT POWER REQUIREMENTS
- CMD 73 PSE UNCAE ARMATURE 100 ST COIL SEAL BREAK ISSUE LOAD 2: 110 DC EXECUTE 107 ST SINE DUST COVER ISSUE LOAD 4: 120 MS DUST COVER REMOVAL 130 SINE PULSICAL
- SINGLE POLE/SINGLE THROW MOMENTARY CONTACT FOUR-ANG SWITC: ASTRONAUT TURN ON SEQUENCE 1 EXP 1 (PSE) 3 EXP 4 (DSE) 2 EXP 2 (LSM) 4 EXP 3 (SBS)
- NOTES:
- AT-2: RCVR XTAL A DEG F MEASURED ONLY WHEN LOCAL OSC IS OPERATIONAL
- AT-2: RCVR XTAL B DEG F MEASURED ONLY WHEN LOCAL OSC IS OPERATIONAL
- AT-2: XMTTR A XTAL DEG F MEASURED ONLY WHEN XMTTR A IS OPERATIONAL
- AT-2: XMTTR B XTAL DEG F MEASURED ONLY WHEN XMTTR B IS OPERATIONAL
- AT-2: XMTTR B XTAL DEG F MEASURED ONLY WHEN XMTTR B IS OPERATIONAL
- AT-2: XMTTR B XTAL DEG F MEASURED ONLY WHEN XMTTR B IS OPERATIONAL

\*

SECTION 5  
COMMAND SUBSYSTEM

5.1 SYSTEM DESCRIPTION

The ALSEP command subsystem receives, decodes, and supplies commands to applicable users to control prescribed operations.

The delayed-command sequencer will generate fixed commands, at predetermined times under the control of the central station timer, to insure that critical enabling and calibration functions are implemented in the event of an uplink failure.

The following units make up the ALSEP command subsystem:

- A. S-band antenna
- B. Diplexer filter
- C. Command receiver
- D. Command decoder

5.1.1 S-Band Antenna

The ALSEP antenna is a modified axial helix designed to receive and transmit right-hand circular polarized signals at the Apollo S-band frequency.

The antenna has no command requirements, TM measurements, or power requirements. Antenna operating parameters are presented in the following table:

Mode	Antenna gain	Frequency	Beamwidth	Polarization
Transmit	15.2 dB	S-band	27°	Right-hand
Receive	14.7 dB	S-band	27°	Right-hand

5.1.2 Diplexer Filter

The diplexer is used to couple the received RF from the antenna to the command receiver and to couple the RF signal from the ALSEP transmitter to the antenna.

The diplexer filter has no command requirements, TM measurements, or power requirements.

5.1.3 Command Receiver

- A. The command receiver is a narrow-band FM type, incorporating an FM discriminator for carrier phase modulation detection.

Receiver characteristics are as follows:

Frequency . . . . .	2119 MHz $\pm$ 0.001%
Dynamic range . . . . .	-101 to -61 dBm
IF bandwidth . . . . .	275 kHz at 3 dB
Power . . . . .	820 mW
TM parameters . . . . .	5

- B. The receiver has redundant local oscillators which are controlled by a level sensor and switch module. When the output power of the local oscillator falls below a given threshold, the switching circuit will switch +12 Vdc to the redundant local oscillator. When power is applied to the receiver, the switching circuit will search between the redundant oscillators until one of the oscillators provides the necessary signal level, at which time the searching between local oscillators will be terminated. The search interval is from 200 to 400 ms. The oscillator in use can be determined by AT-21 (RCVR XTAL A DEG F) or AT-22 (RCVR XTAL B DEG F).

- C. Receiver local oscillator switchover point - The receiver local oscillator level, TM measurement AE-14, will normally indicate 6.0 dbm. Local oscillator switchover will occur at approximately 1.0 dBm.

\*

ALSEP A2  
BASIC

D. Receiver power requirements are presented in the following table:

Voltage bus	Watts	mAdc	Circuit protection
+12 Vdc $\pm$ 1%	0.79	66.0	CB-01 110 to 225 mA
-6 Vdc $\pm$ 1%	0.03		None

NOTE

Receiver overload causes CB-01 to switch on the 1.25-watt (10<sup>4</sup> mAdc at +12 Vdc) receiver heater. CB-01 is reset by the 18-hour timer pulse.

5.1.4 Command Decoder

The decoder consists of the following sections:

- A. Demodulator section
- B. Redundant digital decoder section
- C. Delayed command sequencer
- D. Resettable solid-state timer

Command decoder power requirements are presented in the following table:

Voltage bus	Watts	mAdc	Protection
+12 Vdc $\pm$ 1%	0.325	27.1	None
+5 Vdc $\pm$ 1%	.775	155	None
-6 Vdc $\pm$ 1%	.230	38.4	None

5.1.4.1 Demodulator section.- The demodulator section accepts the composite audio subcarrier from the command receiver. The composite audio subcarrier is the linear sum of the data and

\*

ALSEP A2  
BASIC

sync subcarriers, where the 2-kc data subcarrier is modulated by a 1000 bit-per-second data stream and the sync signal is a 1-kc subcarrier.

The 1-kc subcarrier is used to phase-lock a voltage controlled oscillator (VCO) in order to assure command bit synchronization during the decoding process. The detection and extraction of the command bits is accomplished by comparing the 2-kc subcarrier with a 2-kc synchronized signal produced by the VCO, which is phase-locked by the 1-kc subcarrier signal.

5.1.4.2 Digital decoder section.-

A. A redundant digital decoder section is provided. The digital decoders are identical but require different decoder addresses. A command can be executed by either decoder by selecting the proper decoder address. The decoder addresses for ALSEP 1 are the following:

1. ALSEP 1 decoder A 1001110 (octal 116)
2. ALSEP 1 decoder B 0001110 (octal 016)

The system is unique in that it does not use sub-bit encoding.

The ALSEP command structure consists of 21 bits:

1001110	1000100	0111011
7 bits	7 bits	MSB 7 bits LSB
Decoder address	Command complement	Command

A bit-by-bit comparison is made between the command complement and the command for error protection. A minimum of 20 bits must precede the command to insure phase lock, and a minimum of 20 bits follow the command to allow for command execution.

Upon receipt of a command, a command verification word is inserted in Word 46 of the TM downlink. The command verification word consists of ten bits. Seven bits in the downlink word are the command received and one bit, called the parity bit, indicates that the command and command complement did or did not compare.

<u>DA-7</u>	<u>DA-5</u>	<u>DA-6</u>
00	0111011	1
MSB	7 bits	LSB
2 bits	Command received	1 bit
Filler bits		Parity

Parity Bit "1": Command and command complement compared, and command was executed.

Parity Bit "0": Command and command complement did not compare, and command was not executed.

- B. Normal decoder operation - The redundant decoders A and B receive the command data, timing pulses, and the threshold signal simultaneously. The threshold signal is used to indicate to the decoders that phase lock has been achieved. Decoders A and B will search through the command data until one decoder receives a valid address, at which time the other decoder is inhibited. The decoder that received the valid address starts its programer at the count of 29. At a count of 36, the command complement is contained in the decoder shift register. At this time, a bit-by-bit comparison is made against the incoming command. At a programer count of 43, the command is contained in the shift register. If a compare was made, the command is executed for 20 ms, until the programer count is 63. Noncomparison will prevent execution of the command. The command can be downlinked as a command verification word (CVW) only after the count of 63 through 2047.



\*

ALSEP A2  
BASIC

The seven bits of command information and the one bit that indicates compare or no compare are held in the shift register until a data demand signal from the data processor at Word 46 time is inputted, at which time the eight bits are shipped serially to the digital processor to be inserted into Word 46 of the PCM downlink. The end of the data demand signal generates a data end reset signal which returns the decoders to the search mode.

C. Command-decoder reset capability

1. Power reset - A separate power reset circuit is provided for decoders A and B. The purpose of this is to assure that both decoders will start in the search mode when power is applied to ALSEP. The reset circuits will also reset the decoders to the search mode in case of a momentary drop of approximately 3 Vdc on the 5-Vdc bus. The power reset circuit in decoder A will reset the timer inhibit circuit in the timer pulse-shaping section and allow the command decoder to accept the 18-hour and the 1-minute pulses from the timer. If a power reset signal is received during the decoding process of a command, the decoding process will be terminated at that time, and the decoders will return to the search mode. If a power reset is received after the decoding process is complete, the command will be executed, but a CVW will not be received. A power reset will also reset the delayed-command sequencer logic to zero count.
2. Demand override reset - In the event that the decoders did not receive a data end reset signal, the decoder programmer will generate a reset signal 1984 ms (programmer count 2047) after command execution.

3. Threshold loss reset - Loss of phase-lock between the 1-kc sync signal that is uplinked and the 1-kc signal derived from the 8-kc VCO during the decoding process of the command will generate a threshold loss reset signal. The decoding process will terminate at this time and the decoders will return to the search mode. If the decoding process has been completed, the command will be executed and a command verification will be received.

5.1.4.3 Delayed-command sequencer.- Provisions have been incorporated to automatically generate seven commands to provide a backup feature in the event of an uplink failure.

The delayed-command sequencer receives 18-hour timing pulses and 1-minute timing pulses from the timer which advance the "hours" and "minutes" counters (see Drawing 5.1). The counters and gates of the delayed-command sequencer will be initialized to zero by a power reset (Para 5.1.4.2.C.1), that is, ALSEP activation at deployment or transients on the 5-Vdc bus, and will be referred to as command sequencer reset. Note that this is not the reset circuitry associated with the timer. Through various combinations of sequence decoding gates connected to these counters, the delayed-command sequencer will output the following commands. The execute times are referenced to command sequencer reset. These commands can be initiated by RTC's or by the delayed-command sequencer, however, the CVW will be available only if the command was by RTC.

\*

ALSEP A2  
BASIC

<u>One-time commands</u>	<u>Normal time of execution after command sequencer reset</u>
SET CCIG SEAL BREAK (Cmd 105) and ARM PSE* UNCAGE CIRCUIT (Cmd 073)	Eight 18-hr pulses + 2 min
EXECUTE CCIG SEAL BREAK (Cmd 110)	Eight 18-hr pulses + 3 min
REMOVE SWS DUST COVER (Cmd 122) and SET SIDE REMOVE DUST COVER (Cmd 107)	Eight 18-hr pulses + 4 min
EXECUTE SIDE REMOVE DUST COVER (Cmd 110)	Eight 18-hr pulses + 5 min

Repetitive command

MAGNETOMETER FLIP CALI- BRATE (Cmd 131)	Nine 18-hr pulses + 1 min and every 18 hours thereafter
--	--

Command 033 inhibits the automatic commands generated by the delayed-command sequencer and the 18-hour timer (see note in Command 033, page 5-15). The 18-hour timer commands are listed below for reference.

5.1.4.4 Timer.- (Refer to Drawing 5.1.) A solid-state, resettable, nonmechanical timer is incorporated in the ALSEP A2 central station. The input power required is +12 Vdc at 0.25 watts, which provides the following outputs to the delayed-command sequencer via the timer accept/inhibit logic:

<u>Rate</u>	<u>Duration</u>	<u>Level</u>
One per minute	1 second	Ground
One per 18 hours (Coincident with the 1-minute pulse)	1 second	Ground

\*Uncaging of the PSE will normally be accomplished by two successive ground commands 073. However, as a backup, two successive 18-hour timer pulses or one 18-hour timer pulse and the eighth 18-hour pulse + 2 minute one-time command will effect uncaging. Arming the uncaging circuit and then placing the PSE to standby will also effect uncaging.

The 18-hour pulse also generates the following repetitive (every 18-hour pulse) commands which are inhibited by Command 033.

- A. COMMAND RECEIVER RESET
- B. SHORT PERIOD CALIBRATE PSE (same as Command 065)
- C. UNCAGE PSE\*
  - 1. ARM UNCAGE PSE (first 18-hour pulse)
  - 2. EXECUTE UNCAGE PSE (second 18-hour pulse)

The timer also provides a relay closure at the end of  $97 \pm 5$  days to terminate transmitter operations.

Three TM parameters are provided to indicate the status of counters 1 and 2 and the 18-hour count. Activation (ALSEP deployment turnon or a loss of the +12 Vdc bus for longer than 30 seconds) will initialize counters 1 and 2 to zero. The counters can also be reset to zero by means of Command 150 (TIMER RESET). The timer storage circuit will allow the counts contained in both counters to be retained for up to 30 seconds in the event of perturbations or transients on the +12 Vdc bus. The transmitter turnoff function will occur when counter 1 and counter 2, both containing counts of 8,388,608, are "anded" together to drive the relay to the closed position. The transmitter can be commanded to ON via Command 013 if the timer turnoff function has occurred.

NOTE

IT IS IMPORTANT TO NOTE  
THAT THE TIMER TRANSMITTER  
TURNOFF FUNCTION CAN OCCUR  
ONE TIME ONLY DUE TO THE  
TIMER LATCHING RELAY AND  
NO RELAY RESET CAPABILITY.

\*Uncaging of the PSE will normally be accomplished by two successive ground commands 073. However, as a backup, two successive 18-hour timer pulses or one 18-hour timer pulse and the eighth 18-hour pulse + 2 minute one-time command will effect uncaging. Arming the uncaging circuit and then placing the PSE to standby will also effect uncaging.

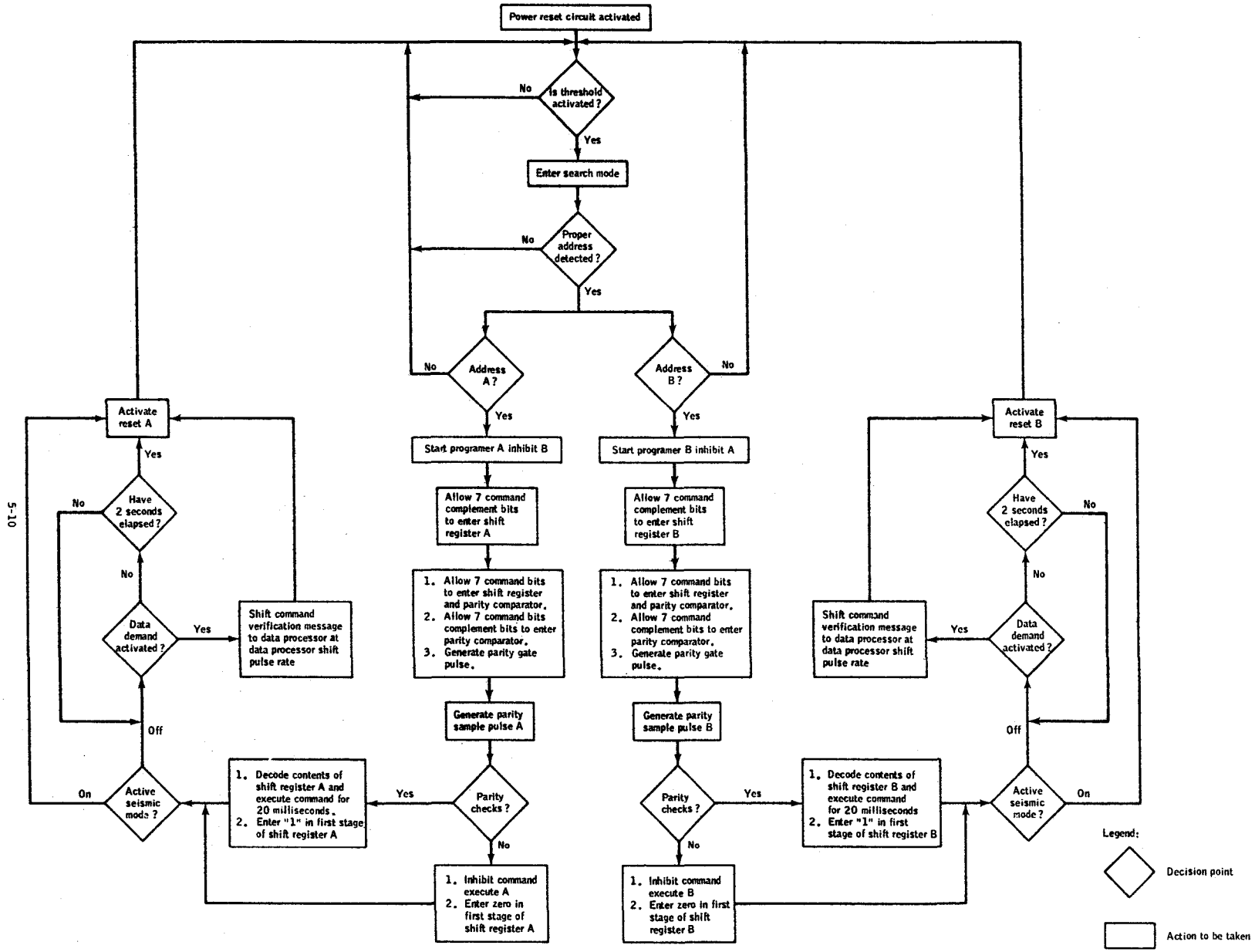

Figure 5-1. - Command decoder flow diagram.

Legend:  
 ◊ Decision point  
 ▭ Action to be taken

5-10

## 5.2 COMMAND FUNCTIONS

## 003 ASE HBR ON DATA PROCESSOR

Command 003 disconnects the data processor from the modulator and connects the modulator to the active seismic processor which supplies the high-bit-rate data (10,600 bps). The ASE HBR ON command takes effect at the scheduled end of the 64-word data-processor frame which is in progress at the time the mode change command is received. The downlink data are meaningless if this command is executed with no ASE in the flight configuration.

## 005 ASE HBR OFF DATA PROCESSOR

Command 005 disconnects the ASE processor from the modulator and connects the modulator to the data processor which supplies data at 530 or 1060 bps, depending on the last bit-rate mode commanded. The ASE HBR OFF command takes effect at the scheduled end of the 64-word data processor frame which is in progress at the time the mode change command is received. Central station activation or power reset initializes ASE HBR to OFF.

## 006 NORM BIT RT SEL DATA PROCESSOR

Command 006 causes the data processor to operate at the normal bit rate (1060 bps). This command takes effect at the scheduled end of the 64-word frame which is in progress at the time the mode change command is received. Central station activation or power reset initializes the data processor to NORMAL BIT RATE.

## 007 LOW BIT RT SEL DATA PROCESSOR

Command 007 causes the data processor to operate at low bit rate (530 bps). This command takes effect at the scheduled end of the 64-word frame which is in progress at the time the mode change command is received.

NOTE

Exp 2 (LSM) data are meaningless on low bit rate.

011 NORM BIT RT RST            DATA PROCESSOR

Command 011 is a provision for returning the operational data processor (determined by Command 034 or 035) to the normal bit rate from either the high or low bit rate. This command does not reset the analog multiplexer or frame counter. This command takes effect immediately and does not wait until the scheduled end of the 64-word frame.

NOTE

Commands that switch bit rates, transmitters, or data processors are commands which will cause a loss of sync at the ground station and a loss or false readout of command verification word.

012 XMTR A SEL                    POWER DISTRIBUTION UNIT

Command 012 actuates relay K-05, in the PDU, to the position that selects transmitter A. XMTR A SEL is the lunar surface initial condition.

013 XMTR ON                        POWER DISTRIBUTION UNIT

Command 013 actuates relay K-04, in the PDU, which applies +29 Vdc to the transmitter selected by Command 012 or 015. This command simultaneously removes +29 Vdc from the 8.4-watt transmitter heater located on the thermal plate. XMTR ON is the lunar surface initial condition.

014 XMTR B SEL                    POWER DISTRIBUTION UNIT

Command 014 actuates relay K-04, in the PDU, to the position that removes +29 Vdc from the transmitter selected by Command 012 or 015. This command simultaneously applies +29 Vdc to the 8.4-watt transmitter heater.

- 015 XMTR B SEL                      POWER DISTRIBUTION UNIT  
Command 015 actuates relay K-05, in the PDU, to the position that selects transmitter B. Actuation of astronaut switch 2 will select and turn on transmitter B.
- 017 DSS HTR 2 ON                      POWER DISTRIBUTION UNIT  
Command 017 actuates relay K-16, in the PDU, to the position that applies +29 Vdc to the 5-watt DSS heater 2.
- 021 DSS HTR 2 OFF                      POWER DISTRIBUTION UNIT  
Command 021 actuates relay K-16, in the PDU, to the position that removes +29 Vdc from the 5-watt DSS heater 2.
- 022 DISSIP R2 ON                      POWER DISTRIBUTION UNIT  
Command 022 actuates relay K-17, in the PDU, to the position that applies +29 Vdc to a 14-watt power dump resistor and is used to optimize the load on the PCU.
- 023 DISSIP R2 OFF                      POWER DISTRIBUTION UNIT  
Command 023 actuates relay K-17, in the PDU, to the position that removes +29 Vdc from the 14-watt power dump resistor.
- 024 DSS HTR 1 ON                      POWER DISTRIBUTION UNIT  
Command 024 actuates relay K-18, in the PDU, to the position that applies +29 Vdc to the 10-watt heater located on the central station thermal plate.
- 025 DSS HTR 1 OFF                      POWER DISTRIBUTION UNIT  
Command 025 actuates relay K-18, in the PDU, to the position that removes the +29 Vdc from the 10-watt central station heater.
- 027 DUST CELLS ON                      POWER DISTRIBUTION UNIT  
Command 027 is a one-state command that activates the DTREM photo cell amplifiers.



031 DUST CELLS OFF                      POWER DISTRIBUTION UNIT

Command 031 is a one-state command that deactivates the DTREM photo cell amplifiers.

032 TIMER OUTPUT ACCPT                COMMAND DECODER

Command 032 enables the 18-hour and the 1-minute timer output pulses, thus allowing automatic commands to be generated by the timer and the delayed-command sequencer. This command cancels the effect of Command 033. Central station activation or power reset initializes the TIMER OUTPUT ACCPT.

033 TIMER OUTPUT INHIB                COMMAND DECODER

Command 033 inhibits the 18-hour and the 1-minute timer output pulses which in turn will disable the following automatic commands generated in the delayed-command sequencer:

<u>One-time commands</u>	<u>Normal time of execution after command sequencer reset</u>
SET CCIG SEAL BREAK and ARM PSE UNCAGE CIRCUIT	Eight 18-hr pulses + 2 min
EXECUTE CCIG SEAL BREAK	Eight 18-hr pulses + 3 min
REMOVE SWS DUST COVER and SET SIDE REMOVE DUST COVER	Eight 18-hr pulses + 4 min
EXECUTE SIDE REMOVE DUST COVER	Eight 18-hr pulses + 5 min

Repetitive command

MAGNETOMETER FLIP CALI- BRATE	Nine 18-hr pulses + 1 min and every 18 hours
----------------------------------	---

Command 033 will also disable the following automatic commands generated by the timer. These are repetitive (every 18-hour pulse commands):

- A. COMMAND RECEIVER RESET
- B. SHORT PERIOD CALIBRAGE PSE

C. UNCAGE PSE

1. ARM UNCAGE PSE (first 18-hour pulse)
2. EXECUTE UNCAGE PSE (second 18-hour pulse)

NOTE

SINCE THIS COMMAND INHIBITS  
THE RECEIVER RESET, IT IS  
CONSIDERED HIGHLY CRITICAL.

This command will input level changes to the hours and minutes counters of the delayed-command sequencer and advance the counters by 18 hours and 1 minute. This may change the execution times of the automatic commands from the delayed-command sequencer and the timer.

This command does not inhibit or affect the 3-month transmitter turnoff command generated by the timer.

034 DSS/PROC X SEL                      POWER DISTRIBUTION UNIT

Command 034 actuates relays K-02 and K-03, in the PDU, to the position that applies operational power to the X digital data processor, X 90-channel analog multiplexer, and X A/D converter. The digital data processor will initialize in the normal bit rate. Command 034 simultaneously deselects the Y system. DSS/PROC X SEL is the lunar surface initial condition.

035 DSS/PROC Y SEL                      POWER DISTRIBUTION UNIT

Command 035 activates relays K-02 and K-03, in the PDU, to the position that applies operational power to the Y digital data processor, Y 90-channel analog multiplexer, and Y A/D converter. The digital data processor will initialize in the normal bit rate. Command 035 simultaneously deselctcs the X system. Activation of astronaut switch 2 provides the same function as Command 035.

ALSEP A2  
BASIC

036 EXP 1 OPER SEL (PSE) POWER DISTRIBUTION UNIT

Command 036 actuates relay K-06, in the PDU, applying +29 Vdc to the PSE instrument and the heater circuitry in the deployed PSE sensor assembly. It simultaneously removes +29 Vdc from the standby heater in the PSE electronics package in the central station.

037 EXP 1 STBY SEL (PSE) POWER DISTRIBUTION UNIT

Command 037 actuates relays K-06 and K-07, in the PDU, applying +29 Vdc to the standby heater in the PSE electronics package and to the heater in the deployed sensor assembly. It simultaneously deactivates the PSE by removing +29 Vdc from the instrument. EXP 1 STBY SEL (PSE) is the lunar surface initial condition.

041 EXP 1 STBY OFF (PSE) POWER DISTRIBUTION UNIT

Command 041 actuates relay K-07, in the PDU, to the position that removes +29 Vdc from both PSE heater circuits. If the PSE operating power is on, transmission of this command will have no effect.

042 EXP 2 OPER SEL (LSM) POWER DISTRIBUTION UNIT

Command 042 actuates relay K-08, in the PDU, applying +29 Vdc to activate the LSM.

043 EXP 2 STBY SEL (LSM) POWER DISTRIBUTION UNIT

Command 043 actuates relays K-08 and K-09, in the PDU, to the position that deactivates the LSM instrument but does not apply standby power. EXP 2 STBY SEL (LSM) is the lunar surface initial condition.

044 EXP 2 STBY OFF (LSM) POWER DISTRIBUTION UNIT

Command 044 actuates relay K-09, in the PDU, to the position that removes +29 Vdc from the resistive summing network to TM parameter AB-4. The LSM uses no standby power. If the LSM operating power is on, transmission of this command will have no effect.

\*

ALSEP A2  
BASIC

- 045 EXP 3 OPER SEL (SWS) POWER DISTRIBUTION UNIT  
Command 045 actuates relay K-10, in the PDU, applying +29 Vdc to activate the SWS instrument. This command simultaneously deactivates the SWS standby heater.
- 046 EXP 3 STBY SEL (SWS) POWER DISTRIBUTION UNIT  
Command 046 actuates relays K-10 and K-11, in the PDU, applying +29 Vdc to the SWS standby heater. This command simultaneously deactivates the SWS instrument. EXP 3 STBY SEL (SWS) is the lunar surface initial condition.
- 050 EXP 3 STBY OFF (SWS) POWER DISTRIBUTION UNIT  
Command 050 actuates relay K-11, in the PDU, to the position that removes +29 Vdc from the SWS standby heater. If the SWS operating power is on, transmission of this command will have no effect.
- 153 EXP 4 OPER SEL (SIDE/CCGE) POWER DISTRIBUTION UNIT  
Command 153 actuates relay K-12, in the PDU, applying +29 Vdc to the SIDE instrument and the SIDE heater.
- 053 EXP 4 STBY SEL (SIDE/CCGE) POWER DISTRIBUTION UNIT  
Command 053 actuates relays K-12 and K-13, in the PDU, applying +29 Vdc to the SIDE heater. It simultaneously deactivates the SIDE by removing +29 Vdc from the instrument. EXP 4 STBY SEL (SIDE) is the lunar surface initial condition.
- 054 EXP 4 STBY OFF (SIDE/CCGE) POWER DISTRIBUTION UNIT  
Command 054 actuates relay K-13, in the PDU, to the position that removes +29 Vdc from the SIDE heater. If the SIDE operating power is on, transmission of this command will have no effect.
- 055 EXP 5 OPER SEL (HFE) POWER DISTRIBUTION UNIT  
Command 055 actuates relay K-14, in the PDU, applying

ALSEP A2  
BASIC

\*  
+29 Vdc to the HFE instrument and the heater circuitry in the deployed HFE electronics assembly. It simultaneously removes +29 Vdc from the standby heater in the HFE electronics package.

- 056 EXP 5 STBY SEL (HFE)                      POWER DISTRIBUTION UNIT  
Command 056 actuates relays K-14 and K-07, in the PEU, applying +29 Vdc to the standby heater in the HFE electronics package. It simultaneously deactivates the HFE by removing +29 Vdc from the instrument. EXP 5 STBY SEL (HFE) is the lunar surface initial condition.
- 057 EXP 5 STBY OFF (HFE)                      POWER DISTRIBUTION UNIT  
Command 057 actuates relay K-15, in the PDU, to the position that removes +29 Vdc from the HFE heater circuit. If the HFE operating power is on, transmission of this command will have no effect.
- 060 PCU 1 SEL                                      POWER CONDITIONING UNIT  
Command 060 actuates relay K-01, in the PCU, which applies +16 Vdc from the RTG to PCU 1 and simultaneously de-energizes PCU 2. PCU 1 is preset to be energized at initial lunar activation. Note that there is an automatic switchover feature to PCU 2 in the event the +12 Vdc bus varies more than  $\pm 1$  Vdc. Adding or removing electrical loads (via ground commands) on PCU 1 can prevent the +12 Vdc bus from varying out of limits.

NOTE

IN THE EVENT AUTOMATIC SWITCHOVER TO PCU 2 HAS OCCURRED, THIS COMMAND MUST BE FLAGGED AS HIGHLY CRITICAL. THE CAUSE OF THE SWITCHOVER MUST BE DETERMINED BEFORE THIS COMMAND IS EXECUTED.

SWITCHOVER FROM PCU 1 TO PCU 2 MAY GENERATE A POWER RESET SIGNAL TO THE DELAYED COMMAND SEQUENCER COUNTERS, RESETTING THE COUNTERS BACK TO ZERO. PCU SWITCHING WILL CAUSE SYNC LOSS AT GROUND STATION.

ALSEP A2  
BASIC

062 PCU 2 SEL

POWER CONDITIONING UNIT

Command 062 actuates relay K-01, in the PCU, which applies +16 Vdc from the RTG to PCU 2 and simultaneously de-energizes PCU 1.

NOTE

AT THE TIME OF LUNAR ACTIVATION, PCU 2 IS DE-ENERGIZED WITH NO MEANS TO DETERMINE ITS CONDITION. FURTHER, NOTE THAT THERE IS NO AUTOMATIC SWITCHOVER FROM PCU 2 TO PCU 1. THIS SITUATION, THEREFORE, MAKES THIS COMMAND HIGHLY CRITICAL. THIS COMMAND SHOULD BE EXECUTED ONLY AFTER DETERMINING THAT PCU 1 IS ON THE VERGE OF FAILING.

SWITCHOVER FROM PCU 2 TO PCU 1 MAY GENERATE A POWER RESET SIGNAL TO THE DELAYED-COMMAND SEQUENCER COUNTERS, RESETTING THE COUNTERS BACK TO ZERO. PCU SWITCHING WILL CAUSE SYNC LOSS AT GROUND STATION.

063 PSE/XY GAIN CH

EXP 1 (PSE)

Command 063 switches different attenuator values into the LPX and LPY amplifier circuits to allow gain control of the long period X- and Y-axis signals. Repeated transmission of the command will cause the attenuators to step through values of 0, -10, -20, and -30 dB in a repeating sequence. In addition, this command controls the calibration current of these two axes. Pse activation initializes the attenuators to -30 dB.

064 PSE/Z GAIN CH

EXP 1 (PSE)

Command 064 switches different attenuator values into the LPZ amplifier circuit to allow gain control of the long period Z-axis signal. Repeated transmission of the command will cause the attenuator to step through values of 0, -10, -20, and -30 dB in a repeating sequence. In addition, this command controls the calibration current of this axis. PSE activation initializes the attenuator to -30 dB.

065 PSE/SP CAL CH                    EXP 1 (PSE)

Command 065 activates logic that will apply a current, via the SP calibration attenuator, to the SP calibration coil. The amount of current from the calibration attenuator is determined by Command 067. In addition, the SP calibration is automatically performed every 18 hours by means of the timer unless specifically inhibited by Command 033. This is a sequential on/off command. PSE activation initializes SP calibration to OFF.

066 PSE/LP CAL CH                    EXP 1 (PSE)

Command 066 activates logic that applies current, via the LP calibration attenuators, to the LP damping coils (all three axes simultaneously). The amount of current from the calibration attenuators is determined by Command 063 and Command 064. This is a sequential on/off command. PSE activation initializes LP calibration to OFF.

067 PSE/SP GAIN CH                    EXP 1 (PSE)

Command 067 switches different attenuator values into the SPZ amplifier circuit to allow gain control of the SP axis signal. Repeated transmission of the command will cause the attenuator to step through values of 0, -10, -20, and -30 dB in a repeating sequence. In addition, this command controls the calibration current of this axis. PSE activation initializes the attenuator to -30 dB.

070 LVL MTRX ON/OFF                    EXP 1 (PSE)

Command 070 activates logic which applies power to the X-axis drive motor. This is a sequential on/off command. PSE activation initializes X motor to OFF. Note that the X motor consumes power in either leveling mode (AUTOMATIC/FORCED) until commanded OFF.

\*

ALSEP A2  
BASIC

NOTE

Do not turn on more than one leveling motor at a time. De-energize sensor heater via Command 076 during time any level motor is on.

071 LVL MTRY ON/OFF            EXP 1 (PSE)

Command 071 activates logic which applies power to the Y-axis drive motor. This is a sequential on/off command. PSE activation initializes Y motor to OFF. Note that the Y motor consumes power in either leveling mode (AUTOMATIC/FORCED) until commanded OFF.

NOTE

Do not turn on more than one leveling motor at a time. De-energize sensor heater via Command 076 during time any level motor is on.

072 LVL MTRZ ON/OFF            EXP 1 (PSE)

Command 072 activates logic which applies power to the Z-axis drive motor. This is a sequential on/off command. PSE activation initializes Z motor to OFF. Note that the Z motor consumes power in either leveling mode (AUTOMATIC/FORCED) until commanded OFF.

NOTE

DO NOT TURN ON Z LEVELING MOTOR WHILE PSE IS CAGED. Do not turn on more than one leveling motor at a time. De-energize sensor heater via Command 076 during time any level motor is on.

073 UNCAGE ARM/FIRE            EXP 1 (PSE)

A. Command 073 is a two-state command (ARM/FIRE). First transmission will arm the actuator circuit. Second transmission of this command is sent to fire the



\*

ALSEP A2  
BASIC

actuator circuit and uncage all spring mass systems simultaneously. This command is an irreversible function and is necessary to obtain PSE scientific data.

- B. The ARM and FIRE commands are also automatically generated by the timer every 18 and 36 hours, respectively, after PET-zero.
- C. Conditions to ARM:
  - 1. First transmission of Command 073
  - 2. First 18-hour timer pulse
  - 3. Eight 18-hour pulses + 2 minutes
- D. Conditions to FIRE (after ARM, above):
  - 1. Next transmission of Command 073
  - 2. Next 18-hour timer pulse
  - 3. If armed, placing PSE to standby (Command 037 or operational overload)

NOTE

THE UNCAGE CIRCUITRY WILL NOT  
FUNCTION BELOW 30° F.

074 LVL DIR POS/NEG            EXP 1 (PSE)

Command 074 is a two-state command (POS/NEG) which controls the direction of the level motors for LPX, LPY, and LPZ axes when in the forced leveling mode (see Command 103). PSE activation initializes leveling direction to POS.

075 LVL SPEED HI/LO            EXP 1 (PSE)

Command 075 is a two-state command (HI/LO) which controls the speed of the leveling motors for LPX, LPY, and LPZ axes when in the forced leveling mode (see Command 103). PSE activation initializes leveling speed to LO.

\*

ALSEP A2  
BASIC

076 PSE T CTL CH                    EXP 1 (PSE)

Command 076 is a four-state command that can be sequentially stepped through the following modes to control the heater in the deployed PSE sensor:

- A. OFF - +29 Vdc disconnected from the heater
- B. FORCED - +29 Vdc applied to heater and automatic thermostat control disabled
- C. OFF - +29 Vdc disconnected from the heater
- D. AUTOMATIC - +29 Vdc applied to heater and automatic thermostat control enabled

PSE activation initializes thermal control mode to AUTOMATIC.

NOTE

This command does not control the heater in the PSE electronics package in the central station. Also, the PSE sensor heater is not controlled by this command when the experiment is in EXP 1 STBY SEL.

101 PSE FILT IN/OUT                EXP 1 (PSE)

Command 101 is a two-state command (IN/OUT) which effectively removes the feedback loop filters from the LPX, LPY, and LPZ axes. PSE activation initializes the feedback filter to OUT. The feedback filter has to be in the following modes for the PSE to operate properly:

- A. Leveling (all modes) - filter OUT
- B. Calibration - filter IN
- C. Normal operational mode - filter IN

102 LVL SNSR IN/OUT                EXP 1 (PSE)

Command 102 is a two-state command (IN/OUT) which activates logic that enables the coarse level sensors to control the LPX and LPY axis drive motors when an off level condition exists. The coarse level sensors are used only in the

\*

ALSEP A2  
BASIC

automatic leveling mode. PSE activation initializes the coarse level sensor to OUT.

103 PSE LVL MDE A/F            EXP 1 (PSE)

Command 103 is a two-state command (AUTOMATIC/FORCED) which controls the leveling mode of LPX, LPY, and LPZ axes. PSE activation initializes the leveling mode to AUTOMATIC.

NOTE

Only one axis motor is to be on at a time.

SIDE/CCGE COMMANDS            EXP 4 (SIDE/CCGE)

The following commands are encoded by the SIDE into two one-time commands and 15 operational commands:

- 104 SIDE LOAD 1
- 105 SIDE LOAD 2
- 106 SIDE LOAD 3
- 107 SIDE LOAD 4\*
- 110 SIDE EXECUTE\*

Encoding is as follows:

	<u>Function</u>	<u>SIDE command register encoding</u>				
		<u>104</u>	<u>105</u>	<u>106</u>	<u>107</u>	<u>110</u>
One Time Commands	{ BREAK CCIG SEAL		X			X
	{ REMOVE DUST COVER				X	X
	1. GND PLANE STEP PROGRAMER ON/OFF	X				X
	2. RESET SIDE FRAME COUNTER AT 10		X			X
	3. RESET SIDE FRAME COUNTER AT 39	X	X			X
	4. RESET VELOCITY FILTER AT 9			X		X
	5. RESET SIDE FRAME COUNTER AT 79	X		X		X

\*Refer to Note 1, Figure 11-1.

<u>Function</u>	<u>SIDE command register encoding</u>				
	<u>104</u>	<u>105</u>	<u>106</u>	<u>107</u>	<u>110</u>
6. RESET SIDE FRAME COUNTER AT 79 AND VELOCITY FILTER AT 9		X	X		X
7. X10 ACCUMULATION INTERVAL ON/OFF	X	X	X		X
8. MASTER RESET				X	X
9. VELOCITY FILTER VOLTAGE ON/OFF	X			X	X
10. LECPA HIVOLTAGE ON/OFF		X		X	X
11. HECPA HIVOLTAGE ON/OFF	X	X		X	X
12. FORCE CONTINUOUS CALIBRATION (RESET TO 120)			X	X	X
13. CCIG HIVOLTAGE ON/OFF	X		X	X	X
14. CHANNELTRON HIVOLTAGE ON/OFF		X	X	X	X
15. RESET COMMAND REGISTER	X	X	X	X	X

NOTE

Commands to break CCIG seal and reset SIDE frame counter at 10 are identical. The first transmission of Commands 105 and 110 causes both functions to occur but not thereafter. Commands to remove dust cover and master reset are also identical. The first transmission of Commands 107 and 110 causes both functions to occur but not thereafter.

The SIDE/CCIG commands are functionally divided into two types: on/off commands and mode commands. Initiation of a mode command changes the operational data format characteristics.

Operationally executing any mode or on/off command will eliminate the existing operational mode. Operationally executing any of on/off commands 1, 7, 9, 10, 11, 13, or 14 will reset the SIDE frame counter (DI-1) to zero if any of the mode commands 2, 3, 4, 5, 6, or 12 is present in the mode register, whereas

\*  
execution of mode commands will not affect the status of any on/off commanded functions.

A brief description of SIDE commands follows:

A. One-time commands:

BREAK CCIG SEAL

Command 105 followed by 110 causes the one-time function of CCIG seal break. It simultaneously resets the SIDE FRAME COUNTER AT 10 (described later). This command is an irreversible function and is necessary to obtain CCGE scientific data. This command is also generated by the delayed-command sequencer (see Command 033).

REMOVE DUST COVER

Command 107 followed by 110 causes the one-time function of blowing the SIDE dust cover. It simultaneously resets the SIDE MASTER RESET (described later). This command is an irreversible function and is necessary to obtain SIDE scientific data. This command is also generated by the delayed-command sequencer (see Command 033). REMOVE DUST COVER command may cause a heater interrupt. (Refer to Figure 11-1.)

B. On/off commands and mode commands:

1. GROUND PLANE STEP PROGRAMER ON/OFF      EXP 4 (SIDE/CCGE)

Command 104 followed by 110 is a two-state command (ON/OFF) that controls the operation of the ground plane step programer. SIDE activation initializes the programer to ON. The ground plane voltage is then stepped through 24 levels (one level/SIDE cycle). Transmission of this command will cause the step programer to stop. Retransmission will start step

programmer and does not reset voltage level to zero but continues to step from level where last stopped.

2. RESET SIDE FRAME COUNTER AT 10      EXP 4 (SIDE/CCGE)  
Command 105 followed by 110 is a mode command.  
(Initiation of a mode command changes the operational data format characteristics.) Upon receipt of the command, the experiment resets to SIDE frame zero and then steps to SIDE frame 10 before resetting again to zero. The velocity filter and the high- and low-energy curved-plate analyzers step through the values obtained for these SIDE frames in the normal mode of operation. The ground plane voltage steps through the normal 24-step sequence, one step per 11-frame cycle. (See Figure 11-3.)
3. RESET SIDE FRAME COUNTER AT 39      EXP 4 (SIDE/CCGE)  
Commands 104 and 105, followed by 110, is a mode command. Upon receipt of the command, the experiment operates in a similar fashion to the reset at 10 mode except that it resets at SIDE frame 39. (See Figure 11-4.)
4. RESET VELOCITY FILTER COUNTER AT 9      EXP 4 (SIDE/CCGE)  
Command 106 followed by 110 is a mode command. The experiment, in this mode, executes the normal 128 SIDE frame cycle. The velocity filter voltage only executes the first 10 of its normal 20-step program. That is, at SIDE frame 10, instead of completing the 20 steps, the velocity filter assumes the value of SIDE frame 20 in the normal mode. Similarly at SIDE frame 20, the filter adopts the normal mode value of SIDE frame 40. This operation continues for the complete 128 SIDE frames. The low-energy curved-plate analyzer, instead of maintaining its value for 20 SIDE frames,

ALSEP A2  
BASIC

steps to the next value every 10 SIDE frames. This means that the six values are repeated from SIDE frame 60. (See Figure 11-5.)

5. RESET SIDE FRAME COUNTER AT 79      EXP 4 (SIDE/CCGE)  
Commands 104 and 106, followed by 110, is a mode command. Upon receipt of the command, the experiment operates in a similar fashion to the reset at 10 mode except that it resets at SIDE frame 79. (See Figure 11-4.)
6. RESET SIDE FRAME COUNTER AT 79  
AND VELOCITY FILTER COUNTER AT 9      EXP 4 (SIDE/CCGE)  
Commands 105 and 106, followed by 110, is a mode command. Upon receipt of the command, the experiment performs the functions of command RESET VELOCITY FILTER COUNTER AT 9, but the sequence stops at SIDE frame 79 and repeats. All other functions are unchanged from the normal operational mode.
7. X10 ACCUMULATION INTERVAL ON/OFF      EXP 4 (SIDE/CCGE)  
Commands 104, 105, and 106, followed by 110, is a two-state command (ON/OFF). The accumulation time period is increased from a normal 1.2 seconds (X1) to 12 seconds (X10). Each SIDE frame is downlinked 10 times before advancing to the next SIDE frame. The X10 mode can be used with any counter reset mode.
8. MASTER RESET      EXP 4 (SIDE/CCGE)  
Command 107 followed by 110 is a mode command. Upon receipt of the command, the experiment will return to the normal operational mode. The master reset performs the following:
  - a. Defeats all short cycles
  - b. Resets SIDE frame counter, velocity counter, HECPA and LECPA counters
  - c. Does not disturb any on/off commands or the X10 accumulation interval

9. VELOCITY FILTER VOLTAGE ON/OFF           EXP 4 (SIDE/CCGE)  
Commands 104 and 107, followed by 110, is a two-state command (ON/OFF). Transmission of this command removes velocity filter voltage (i.e., filter voltage equals 0 Vdc). However, the velocity filter programmer is not inhibited, and upon retransmission of this command, the velocity filter assumes the appropriate voltage level of that SIDE frame in process.
10. LOW ENERGY CPA HIGH VOLTAGE ON/OFF   EXP 4 (SIDE/CCGE)  
Commands 105 and 107, followed by 110, is a two-state command (ON/OFF). Transmission of this command removes LECPA voltage (i.e., LECPA equals 0 Vdc). However, the LECPA programmer is not inhibited, and upon retransmission of this command, the LECPA assumes the appropriate voltage level of that SIDE frame in process. With zero voltage, no low-energy data is transmitted.
11. HIGH ENERGY CPA HIGH VOLTAGE ON/OFF   EXP 4 (SIDE/CCGE)  
Commands 104, 105, and 107, followed by 110, is a two-state command (ON/OFF). Transmission of this command removes HECPA voltage (i.e., HECPA equals 0 Vdc). However, the HECPA programmer is not inhibited, and upon retransmission of this command, the HECPA assumes the appropriate voltage level of that SIDE frame in process. With zero voltage, no high-energy data is transmitted.
12. FORCE CONTINUOUS CALIBRATION           EXP 4 (SIDE/CCGE)  
(RESET TO 120)  
Commands 106 and 107, followed by 110, is a mode command. Upon receipt of the command, the experiment resets to SIDE frame 120 and then steps through SIDE frame 127 before resetting again to SIDE frame 120.



13. COLD CATHODE ION GAGE HIGH VOLTAGE ON/OFF EXP 4 (SIDE/CCGE)

Commands 104, 106, and 107, followed by 110, is a two-state command (ON/OFF). Transmission of this command turns off high voltage to the CCIG sensor, thereby disabling all CCGE scientific data.

14. CHANNELTRON HIGH VOLTAGE ON/OFF EXP 4 (SIDE/CCGE)

Commands 105, 106, and 107, followed by 110, is a two-state command (ON/OFF). Transmission of this command removes high voltage from the Channeltron multipliers, thus disabling SIDE scientific data.

15. RESET COMMAND REGISTER EXP 4 (SIDE/CCGE)

Commands 104, 105, 106, and 107, followed by 110, are commands used to clear the command register of any command awaiting execution. Note that SIDE power on will cause the following:

- a. A power reset will force the instrument into the normal mode, which does the following:
  - (1) Removes all short cycles
  - (2) Resets SIDE frame counter, velocity counter, HECPA and LECPA counter
  - (3) Resets ground plane counter
- b. Resets all command flip-flops
- c. Turns on all the internal voltages of the system (velocity filter, HECPA, LECPA, Channeltron high voltage, CCIG high voltage)

- 122 SWS CVR GO EXP 3 (SWS)

Command 122 causes the one-time function of removing the SWS dust covers. This command is an irreversible function and is necessary to obtain SWS scientific data.

\*  
122 SWS CVR GO (Three times  $\leq 10$  seconds)      EXP 3 (SWS)

Command 122, when sent three times within 10 seconds, places the high voltage amplifiers in the high-gain mode. SWS activation presets the amplifiers to be low-gain mode. The low-gain mode of operation causes the 21 voltage steps applied to the Faraday cup sensors during proton and electron measurements to be scaled such that the highest level will be 6 kilovolts. The high-gain mode increases the gain of the amplifiers by a factor of 1.68, with the highest level going to 10 kilovolts. STBY SEL command (046) followed by an OPER SEL command (045) presets the amplifiers to the low-gain mode.

123 LSM RANGE STEPS                      EXP 2 (LSM)

Command 123 is a three-state command that determines the range of the X-, Y-, and Z-axis sensors of the LSM. LSM activation initializes the range to  $\pm 200$  gamma. Repeated application of this command sequences the range through  $\pm 50$ ,  $\pm 100$ ,  $\pm 200$  gamma. The selected range is common to all three sensors.

124 LSM FLD O/S CH                      EXP 2 (LSM)

Command 124 is a seven-state command that controls field offset of the X-, Y-, and Z-axes. LSM activation initializes the offset to 0 percent. Repeated application of this command sequences the offset through +25, +50, +75, -75, -50, -25, and 0 percent of the range selected by Command 123. Example: With Command 123 set to  $\pm 100$  gamma and Command 124 set to +25 percent, the effective range of the addressed sensor would be +125 to -75 gamma (sensor heads in  $0^\circ$  or  $90^\circ$  position).

125 LSM O/S ADD CH                      EXP 2 (LSM)

Command 125 is a four-state command used to address the X-, Y-, and Z-axes for offsetting. LSM activation

\*

ALSEP A2  
BASIC

initializes the offset address to neutral. Neutral is defined as no axis addressed. Repeated application of this command sequences the offset address from X to Y to Z to neutral. Example: With this command set to the X-axis, Command 124 controls the offset of the X-axis only, with Y- and Z-axes unaffected.

127 FLIP/CAL INHIB                   EXP 2 (LSM)

Command 127 is a two-state command (IN/OUT) used to inhibit the flip/calibrate sequence of the LSM. LSM activation initializes the logic to inhibit IN.

NOTE

SINCE THIS COMMAND WILL INHIBIT THE FLIP/CAL COMMAND FROM THE AUTOMATIC DELAYED-COMMAND SEQUENCER (SEE COMMAND 033) AND GROUND COMMAND 131, THIS COMMAND MUST BE CONSIDERED CRITICAL BECAUSE OF A POSSIBILITY OF UPLINK FAILURE.

131 FLIP/CAL GO                   EXP 2 (LSM)

Command 131 is a one-state command that initiates the flip/calibration cycle. Execution of this command activates the flip/cal sequencer, and upon completion of the sequence, the LSM is returned to the normal operating mode and places the sequencer in OFF.

NOTE

THERE MUST BE EXACTLY FOUR FLIP/CALIBRATE CYCLES BEFORE PERFORMING A SITE SURVEY. In addition to ground Command 131, the flip/calibrate delayed-command sequencer (see Command 033) will generate flip/cal commands.

132 LSM FILT IN/OUT                    EXP 2 (LSM)

Command 132 is a two-state command (IN/OUT). LSM activation initializes the filter to IN. Application of the command to OUT will cause a major portion of the digital filter to be bypassed.

133 SITE SURVEY XYZ                    EXP 2 (LSM)

Command 133 is a one-state command that activates the site survey sequence generator. The first application of this command will initiate the sequence to survey the X-axis. Upon completion of the X-axis survey, the LSM instrument will return to the normal scientific mode. The second and third application of this command will initiate the sequence generator to survey the Y- and Z-axes, respectively, returning the LSM to the normal mode of operation upon completion of the respective axis survey.

NOTE

THE SITE SURVEY MUST BE PERFORMED ONLY AFTER  
FOUR FLIP/CALIBRATE CYCLES HAVE BEEN COMPLETED.

134 LSM T CTL XYO                    EXP 2 (LSM)

Command 134 is a three-state command (X, Y, OFF) which is used to select the X- or Y-axis sensor heater thermostat or to deactivate all LSM heater power. LSM activation initializes the temperature control to the X-axis thermostat. Repeated application of this command sequences the temperature control through Y-axis thermostat, off, and X-axis thermostat. The selected axis thermostat (X or Y) controls heater power to all LSM heaters. In the off position, all LSM heater power is removed. Note that there is no thermostat in the Z-axis sensor.

135 HFE MODE/G SEL                    EXP 5 (HFE)

This command (C1) is a one-state command. It places the HFE in the normal or gradient mode of operation (Mode 1) such that data is obtained from the gradient sensors and

cable thermocouples under the control of the measurement sequence programmer. It also turns off the probe heater current supply. At turnon, the HFE is initialized in this condition.

136 HFE MODE/LK SEL            EXP 5 (HFE)

This command (C2) is a one-state command. It places the HFE in the low conductivity or ring source mode of operation (Mode 2) such that data is obtained from the gradient sensors and cable thermocouples under the control of the measurement sequence programmer. It also turns on the probe heater current supply in the low (or ring source) mode allowing heaters to be activated via Command 152.

140 HFE MODE/HK SEL            EXP 5 (HFE)

This command (C3) is a one-state command. It places the HFE in the high conductivity or heat pulse mode of operation (Mode 3) such that data is obtained from the ring (or remote) sensors under the control of the heater excitation programmer. It also turns on the probe heater current supply in the high (or heat pulse) mode allowing heaters to be activated by Command 152.

141 HFE SEQ/FUL SEL            EXP 5 (HFE)

This command (C4) is a one-state command. It cancels the effect of measurement Commands 142 through 146 and thereby causes the measurement sequence programmer to perform its full 16-state cycle of operation. If transmitted during operation in MODE/HK, this command will cause invalid data. At turnon, the HFE is initialized in this condition.

142 HFE SEQ/P1 SEL            EXP 5 (HFE)

This command (C5) is a one-state command and alternates with Command 143 to select only one probe for measurement.

In MODE/G and MODE/LK it causes the measurement sequence programmer to lock the second flip-flop ( $P_2$ ) in the clear state and bypass that step; that is, act as an eight-state counter if Command 141 was previously executed or as a two-state counter if Command 144, 145, or 146 was previously executed. In MODE/HK this command is meaningless. It is cleared by subsequent execution of Command 141.

143 HFE SEQ/P2 SEL                    EXP 5 (HFE)

This command (C6) is a one-state command and alternates with Command 142 to select only one probe for measurement. In MODE/G and MODE/LK it causes the measurement sequence programmer to lock the second flip-flop ( $P_2$ ) in the set state and bypass that step; that is, act as an eight-state counter if Command 141 was previously executed or as a two-state counter if Command 144, 145, or 146 was previously executed. In MODE/HK this command is meaningless. It is cleared by subsequent execution of Command 141.

144 HFE LOAD 1                        EXP 5 (HFE)

This command (C7) is a one-state command and is used alone or in combination with either Command 145 or 146 to position and lock the measurement sequence programmer's third and fourth flip-flops ( $P_4P_3$ ). It places these two flip-flops in the clear position (00) and bypasses those steps; thus the MSP acts as a four-state counter if Command 141 was previously executed and as a two-state counter if either Command 142 or 143 was previously executed. In MODE/HK this command must be executed, otherwise the data will be invalid. Subsequent execution (in MODE/G or MODE/LK) of Command 145 or 146 locks  $P_4P_3$  in the 01 or 10 state respectively. All positioning and locking of  $P_4P_3$  is cleared by subsequent execution of Command 141.

145 HFE LOAD 2                      EXP 5 (HFE)

This command (C8) is a one-state command and is used in combination with either Command 144 (preceding 145) or Command 146 (preceding or subsequent to 145) to position and lock  $P_4P_3$  (see 144). It sets  $P_3$ ; therefore, 144 followed by 145 placed  $P_4P_3$  in the 01 state. In combination with 146, it places  $P_4P_3$  in the 11 state. Depending on whether Command 141 was previously executed or one of Commands 142 or 143, the MSP acts as a four-state or two-state counter. Execution of this command in MODE/HK causes invalid data until Command 144 is executed. It is cleared by subsequent execution of Command 141.

146 HFE LOAD 3                      EXP 5 (HFE)

This command (C9) is a one-state command operating essentially the same as Command 145 except that it sets  $P_4$ . Therefore, when preceded by 144 it places  $P_4P_3$  in the 10 state.

150 TIMER RESET                      TIMER

Command 150 is a one-state command that will reset timer counters 1 and 2 to a zero count (clear). The 1-minute and the 18-hour output pulses and the timer transmitter turnoff function (at  $97 \pm 5$  days) is referenced to the timer reset. Note that this command does not affect the hours or minutes counters or the sequence decoding gates in the delayed command sequencer or the timer accept/inhibit logic.

NOTE

SINCE THE TIMER TRANSMITTER TURNOFF  
FUNCTION CAN ONLY OCCUR ONE TIME, IT  
IS MANDATORY THAT COMMAND 150 BE SENT  
PRIOR TO TIMER TURNOFF.

152 HFE HTR STEPS

EXP 5 (HFE)

This command (C10) is a 16-state command which advances the heater excitation programmer ( $H_4H_3H_2H_1$ ) each time the command is executed. In MODE/G the programmer advances but there is no other effect since the probe heater current supply is off. In MODE/LK the execution of Command 152 alternates the heater status between on and off, simultaneously stepping through the eight heaters (current supply in on full time, and heater elements are switched in and out of circuit). In MODE/HK the heater excitation programmer (advanced by Command 152) also selects the data to be sampled.

NOTE

HFE commands are executed at the ALSEP 90 frame mark; therefore, there must be 54 seconds delta time between transmission of commands to the HFE.

153 EXP 4 OPER SEL (SIDE/CCGE)

POWER DISTRIBUTION UNIT

Command 153 actuates relay K-12, in the PDU, applying +29 Vdc to the SIDE instrument and the SIDE heater.

NOTE

Command 153 is also listed out of numeric sequence following Command 050.

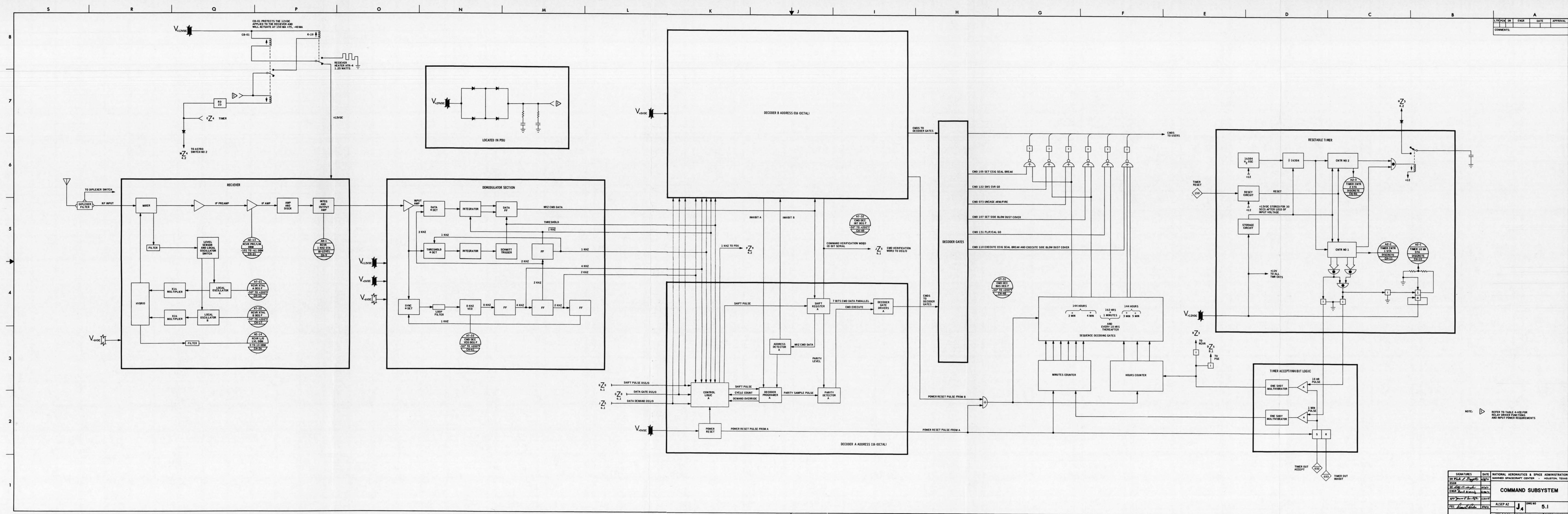

TABLE 5-I.- PRESET AND LUNAR INITIAL CONDITIONS OF SUBSYSTEMS

Subsystem	Command	Function	Initializes to	Lunar initial condition
TM	006	NORM BIT RT SEL	Normal	
TM	012	XMTR A SEL		Xmtr A selected
TM	013	XMTR ON		Xmtr is on
EPS	021	DSS HTR 2 OFF		DSS heater 2 off
EPS	023	DISSIP R2 OFF		Dissip R2 off
S/T	025	DSS HTR 1 OFF		DSS heater 1 off
S/T	027	DUST CELLS ON	On or off	(Random state)
TM	034	DSS/PROC X SEL		D/P X selected
PSE	037	EXP 1 STBY SEL		Exp 1 in standby
LSM	043	EXP 2 STBY SEL		Exp 2 in standby
SWS	046	EXP 3 STBY SEL		Exp 3 in standby
SIDE/CCGE	053	EXP 4 STBY SEL		Exp 4 in standby
HFE	056	EXP 5 STBY SEL		Exp 5 in standby
EPS	060	PCU 1 SEL		PCU 1 selected
CMD	032	TIMER OUT ACCPT	Accept	
PSE	063	PSE/XY GAIN CH	-30 dB	
PSE	064	PSE/Z GAIN CH	-30 dB	
PSE	065	PSE/SP CAL CH	Off	
PSE	066	PSE/LP CAL CH	Off	
PSE	067	PSE/SP GAIN CH	-30 dB	
PSE	070	LVL MTRX ON/OFF	Off	
PSE	071	LVL MTRY ON/OFF	Off	
PSE	072	LVL MTRZ ON/OFF	Off	
PSE	074	LVL DIR POS/NEG	Positive	
PSE	075	LVL SPEED HI/LO	Low	
PSE	076	PSE T CTL CH	Automatic	
PSE	101	PSE FILT IN/OUT	Out	
PSE	102	LVL SEN IN/OUT	Out	
PSE	103	PSE LVL MDE A/M	Automatic	
LSM	123	LSM RANGE STEPS	$\pm 200$ gamma	
LSM	124	LSM FLD O/S CH	Zero percent	
LSM	125	LSM O/S ADD CH	Neutral	
LSM	127	FLIP/CAL INHIB	Inhibit	
LSM	131	FLIP/CAL GO	No-go	
LSM	132	LSM FILT IN/OUT	In	
LSM	133	SITE SURVEY XYZ	No-go	
LSM	134	LSM T CTL XYO	X	
SWS	---	-----	Low gain mode	

TABLE 5-I.- PRESET AND LUNAR INITIAL CONDITIONS OF SUBSYSTEMS - Concluded

Subsystem	Command	Function	Initializes to	Lunar initial condition
SIDE/CCGE		VEL FILT V	On	
SIDE/CCGE		HECPA HV	On	
SIDE/CCGE		LECPA HV	On	
SIDE/CCGE	See	CHAN HV	On	
SIDE/CCGE	SIDE	CCIG HV	On	
SIDE/CCGE	cmd	CMD REG	Zero	
SIDE/CCGE	list,	MODE REG	Zero	
SIDE/CCGE	pages	O/T CMD REG	Preset	
SIDE/CCGE	5-24	FRAME CNTR	Zero	
SIDE/CCGE	to	VEL FILT CNTR	Zero	
SIDE/CCGE	5-30	HECPA CNTR	Zero	
SIDE/CCGE		LECPA CNTR	Zero	
SIDE/CCGE		GND PL PROGRAMER	On	
SIDE/CCGE		GND PL VOLTAGE LEVEL	Zero	
SIDE/CCGE		X10 ACCUM	Off	
SIDE/CCGE			Outputs normal mode	
HFE	135	HFE MODE/G SEL	Gradient mode	
HFE	141	HFE SEL/FUL SEQ	Full 16-step meas seq	



NOTE: REFER TO TABLE 4-VII FOR RELAY DRIVER FUNCTIONS AND INPUT POWER REQUIREMENTS

SIGNATURES	DATE	NATIONAL AERONAUTICS & SPACE ADMINISTRATION
DR <i>[Signature]</i>	5/27/70	MANHATTAN SPACECRAFT CENTER - HOUSTON, TEXAS
DC <i>[Signature]</i>		
ENGR <i>[Signature]</i>		
APP <i>[Signature]</i>		
FEC <i>[Signature]</i>		
ALSEP A2		5.1
104.5 X 34		PAGE 5-40
		SHEET 1 OF 1

SECTION 6

TELEMETRY SUBSYSTEM

6.1 SYSTEM DESCRIPTION

The telemetry subsystem consists of central station sensors, experiment sensors, two analog multiplexers, two analog-to-digital converters, two digital data processors, two S-band transmitters, one diplexer switch, one diplexer filter, and a common S-band transmit/receive helix antenna.

6.1.1 Sensors (Transducers)

Analog sensors convert such parameters as temperature, voltage, current, and status into 0- to +5-volt signals and input these signals to the 90-channel analog multiplexers as engineering (housekeeping) data to indicate the condition of the central station, RTG, PSE, and HFE.

Scientific measurements from the experiment sensors and experiment status, calibration, and temperature data are converted within each experiment to digital data and applied to the X and Y digital data processors at the proper demand time in serial form.

6.1.2 Analog Multiplexers

Analog engineering (housekeeping) data are applied to the redundant 90-channel analog multiplexers. Selection of the redundant multiplexer can be accomplished by Command 034 or 035. Actuation of astronaut switch 2 provides the same function as ground Command 035 (DSS/PROC Y SEL). The multiplexer is divided into 15 groups of six column gates each, and the group outputs are further gated through a tier of eight row gates. The channel advance pulse generated in the digital data processor (occurs at the time of the sixty-fourth

\*

main frame word) is applied to the analog multiplexer sequencers to advance the multiplexers to the next channel after each A/D conversion. The sequencers generate a ninetyeth-channel output pulse that is used to reset the frame counter located in the digital data processor. The output of the analog multiplexer is buffered by amplifiers at the input to each A/D converter.

#### 6.1.3 A/D Converters

The A/D converters encode the analog signal from the multiplexer into an 8-bit digital word when an encode pulse from the digital data processor occurs (once every digital data processor main frame). The 8-bit digital word is input parallel to the digital data processor at Word 33 time of the ALSEP main frame. Selection of the redundant A/D converter is accomplished by Command 034 or 035.

#### 6.1.4 Digital Data Processor

Redundant digital data processors (X and Y) are provided. The redundant processors are selectable by ground Command 034 or 035. The processor that is selected receives data in a parallel form from the A/D converter and in a serial form from the command decoder and experiments. The data are formatted into a serial NRZC format and then encoded into a split-phase signal and applied to the transmitter.

As a backup capability, the data processor provides a low-bit-rate mode at one-half the normal data rate. The normal or low data rate can be selected by ground Commands 006 and 007 respectively.

The first three words of the ALSEP main frame are used for the sync code. The bit assignment for the sync word is shown in Figure 6-3. Bits 23 through 29 are provided for channel

\*  
identification for 1 through 90 channels for correlation of the analog multiplexer data. These bits are derived from a ripple-through counter which is advanced one step whenever Word 1 of the ALSEP main frame occurs and is reset by a ninetyeth-frame signal generated by the analog multiplexers. When power is applied to the data processor, these seven bits will be a random count between 0 and 127 and cannot be used to determine the position of the multiplexers until the ninetyeth-frame reset signal is received from the analog multiplexers.

Each of the redundant processors has a power reset circuit. This circuit will reset the processor to the normal data rate if there is a momentary drop in the +5Vdc line.

The data processor will generate and provide all necessary timing signals to the experiments, command decoder, A/D converter, and the 90-channel analog multiplexers (see Table 6-III).

#### 6.1.5 Transmitter

There are two S-band transmitters (A and B) which are selectable by ground commands. The active transmitter accepts split-phase telemetry data from the data processor and phase-modulates the carrier which is applied to the helix antenna at a 1-watt level on a downlink frequency of 2278.0 MHz. Ground commands are also used to turn the selected transmitter on or off. If the transmitter is commanded off, an 8.4-watt heater is simultaneously activated to provide electrical and thermal balance. Overload protection is provided for both transmitters. The circuit breaker associated with the overloaded transmitter will switch the operating voltage (+29 Vdc) to the other transmitter.

\*  
6.1.6 Diplexer Switch

The diplexer switch is utilized to couple the selected transmitter (A or B) output through the diplexer filter to the antenna. The direction of the diplexer switch (thus the selection of transmitter A or B output) is controlled by activating a ferrite device, within the circulator, by a magnetic field from a coil which is energized by +12 Vdc. The +12 Vdc is applied when transmitter B is on.

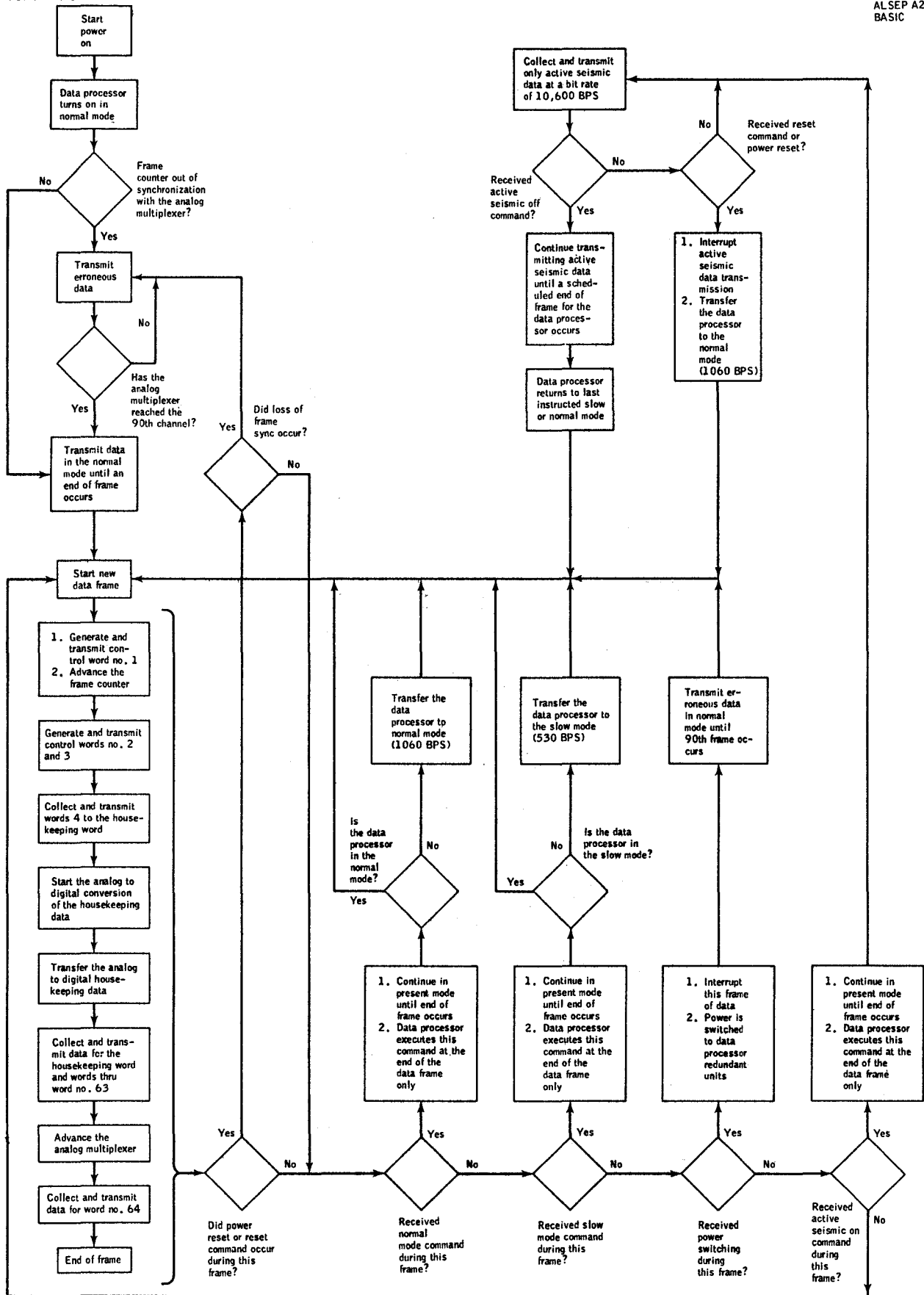

Figure 6-1 - Data processor flow diagram.  
6-5



TABLE 6-I.- ANALOG MULTIPLEXER, A/D CONVERTER CHARACTERISTICS

Analog multiplexer (subcommutated)

Input (from sensors or signal conditioners) . . . 0 to +5 Vdc

Channels/frame . . . . . 90 max

Seconds/frame (normal bit rate) . . . . . 54.34

Seconds/frame (low bit rate) . . . . . 108.68

Redundancy . . . . . X or Y multiplexer

A/D converters

Input (from analog mux) . . . . . 0 to +5 Vdc

Conversion . . . . . 8 bits

Data to D/P . . . . . Parallel

Time slot in main frame . . . . . Word 33

Redundancy . . . . . X or Y converter

Input from 0 to +5 volts . . . . . Outputs 0 to 225  
PCM count

Input from +5 to +8 volts . . . . . Outputs 255 decimal  
PCM count

Input from +8 to +12 volts . . . . . Outputs ambiguous counts  
(0-255)

Input above +12 volts . . . . . Detrimental to the  
analog mux

TABLE 6-II.- DIGITAL DATA PROCESSOR CHARACTERISTICS

Parameter	Low bit rate	Normal bit rates
Data rate (bps)	530	1060
Bits/word . . . .	10	10
Words/frame . . .	64	64
Frame/second . .	53/64	1-21/32
Seconds/frame . .	1.2075	0.6038
Bits/sync word .	22	22
Redundancy . . .	X or Y processor	

Words 1, 2, and 3 are control words. Word 33 of the main frame contains housekeeping data from the analog mux/A/D converter. Word 46 contains the command verification word. The two MSB's of Words 33 and 46 are filler bits inserted by the digital data processor. All main frame words are downlinked MSB first.

DA-4 (Bit 10 of Word 3) contains the data processor serial number.

Frame 3	0 MSB
Frame 4	1
Frame 5	1

NOTE

Either of the two systems, X or Y (redundant analog multiplexers, A/D converters, and digital data processors) are selected by Command 034 (DSS/PROC X SEL) or Command 035 (DSS/PROC Y SEL).

1	2	3	4	5	6	7	8
x	x	x	X	o	X	S	X
9	10	11	12	13	14	15	16
-	X	-	X	-	X	I	X
17	18	19	20	21	22	23	24
o	X	o	X	o	X	S	HF
25	26	27	28	29	30	31	32
-	X	-	X	-	X	I	X
33	34	35	36	37	38	39	40
H	X	•	X	•	X	S	X
41	42	43	44	45	46	47	48
-	X	-	X	-	CV	I	X
49	50	51	52	53	54	55	56
o	X	o	X	o	X	S	I
57	58	59	60	61	62	63	64
-	X	-	X	-	X	I	X

Word totals

Legend

3	x = Sync
28	X = Passive seismic - short period
12	- = Passive seismic - long period
2	• = Passive seismic - long period tidal and one temperature
7	o = Magnetometer experiment
4	S = Solar wind spectrometer experiment
5	I = Suprathermal ion detector experiment
1	HF = Heat flow experiment
1	CV = Command verification
1	H = Housekeeping

Each box contains one 10-bit word

Total bits per frame = 10 x 64 = 640 bits

Data rate = 1060 bits/second or 530 bits/second

Figure 6-2.- Main frame format.

CONTROL GROUP FORMAT

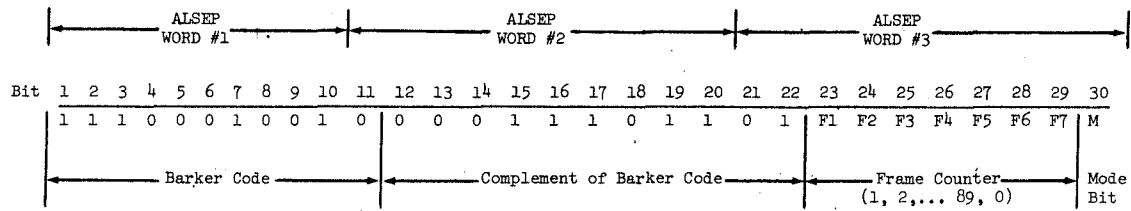

Symbol	Name	ALSEP Words	Range	Bits/ Sample	Samples/ Second
DA-1	Barker Code and Complement	1, 2, and Bits 1 and 2 of Word 3	NA	22	1.67
DA-2	Frame Count	Bits 3 to 9 inclusive of Word 3	0-127 (Frame count reads all zero's on channel 90)	7	1.67
DA-3	Bit Rate ID	Bit 10 of Word 3		1	1.67
		<u>Frame</u> <u>Mode Bit</u>	<u>Meaning</u>		
		1 1	Normal data rate		
		2 1	Low data rate		
DA-4	ALSEP ID	Bit 10, LSB, of Word 3		3	1/54
		<u>Frame</u> <u>Mode Bit</u>			
		3 0 (MSB)	Data processor Serial number ALSEP A2		
		4 1			
		5 1			
DA-5	Received Command Message	Bits 3 to 9 inclusive of Word 46	1 to 127	7	*
DA-6	Command MAP	Bit 10, LSB, of Word 46	"0" no parity "1" parity	1	*
DA-7	Filler Bits	May be used to determine bit error rate during off line processing. Bits 1 and 2 of Word 46.			

\*One word sample is sent for each command received; other samples are all zeros.

Figure 6-3.- Control and command verification word format.

TABLE 6-III.- TIMING FROM DIGITAL PROCESSOR

Signals from data processor	Signal to -						Analog mux and A/D conv
	Cmd decoder	PSE	LSM	SWS	SIDE	HFE	
Shift pulse	X	X	X	X	X	X	
Data gate	X	X					
Even frame mark		X			X		
Frame mark			X			X	
Data demand	X	X	X	X	X	X	
A/D encode							X
Advance pulse							X
90th frame mark						X	

TABLE 6-IV.- TIMING AND CONTROL PULSE CHARACTERISTICS

Pulse type	Duration <sup>a</sup> (μsec)	Repetition rate
Frame mark	118	Once per ALSEP frame
Even frame mark	118	Once every other frame
90th frame mark	118	Once every 90th frame
Data gate (word mark)	118	64, once per each 10-bit word in frame
Data demand	9434	Once per word in ALSEP frame
Shift pulse	47	640 pulses per frame 1060 pulses per second
Command	20,000	Asynchronous

<sup>a</sup>In low bit rate, duration is twice the normal mode.

TABLE 6-V.- TELEMETRY SUBSYSTEM POWER REQUIREMENTS AND OVERLOAD PROTECTION

Component	Voltage bus	Watts	mAdc	Circuit protection
Digital data processor, X or Y	+12 Vdc $\pm$ 1%	0.05		None
	+5 Vdc $\pm$ 1%	0.450		None
Analog multiplexer and A/D converter, X or Y	+15 Vdc $\pm$ 1%	0.05		None
	+12 Vdc $\pm$ 1%	0.140		None
	+5 Vdc $\pm$ 1%	1.10		None
Transmitter A or B	+12 Vdc $\pm$ 1%	0.11		None
	+29 Vdc $\pm$ 1%	10.8	375.0	CB-03 Xmtr A 560 to 840 mA CB-05 Xmtr B 560 to 840 mA
Transmitter heater	+29 Vdc $\pm$ 1%	8.4		None
Diplexer switch	+12 Vdc $\pm$ 1%	0.15	12.5	CB-04 110 to 225 mA

TABLE 6-VI.- TRANSMITTER CHARACTERISTICS

Frequency . . . . . 2278.0 MHz  
 Modulation . . . . . PM  $\pm$  1.25 radian, phase-modulated carrier  
 Stability (long-term) . . .  $\pm$ 0.0025 percent/year  
 Power output . . . . . 1 watt minimum  
 Power input . . . . . 10.0 to 10.8 watts  
 TM parameters . . . . . 4

TABLE 6-VII.- CHANNEL AND MEASUREMENT ASSIGNMENTS FOR ANALOG MULTIPLEXER (ALSEP WORD 33)

Channel Number	Symbol	Location/Name	Channel Number	Symbol	Location/Name
1	AE-3	Converter Input Voltage	46	AT-29	Digital D/P, Base Temp
2	AE-1	0.25 Vdc Calibration	47	AT-30	Digital D/P, Internal Temp
3	AE-2	4.75 Vdc Calibration	48	AT-31	Command Decoder Base Temp
4	AT-3	Thermal Plate Temp 1	49	AT-32	Command Decoder Internal Temp
5	AE-4	Converter Input Current	50	AE-9	PCU Output Voltage 3 (12 V)
6	AR-1	RTG Hot Frame 1 Temp	51	AE-15	Transmitter A, RF Power
7	AR-4	RTG Cold Frame 1 Temp	52	AR-3	RTG Hot Frame 3 Temp
8	AE-5	Shunt Regulator 1 Current	53	AL-3	Level Direction and Speed
9	AE-1	Command Demodulator 1 kHz Present	54	AL-7	Calibration and Status LP and SP
10	AZ-1	Timer 18 Hr Status	55	AH-3	HFE Supply Voltage No. 3 (15 V)
11	AZ-2	Timer Counter No. 1 Status	56	AX-3	DTREM Outer Temp
12	AB-4	Power Distribution Exper 1 and 2 Standby Status	57	AH-6	HFE Low Conductivity Htr Status
13	AE-6	Shunt Regulator 2 Current	58	AT-6	Thermal Plate Temp 4
14	AB-5	Power Distribution Exper 3, 4, 5 Standby Status	59	AT-8	Primary Structure Wall Temp 1 (Left)
15	AT-10	Primary Structure Bottom Temp 1	60	AT-12	Insulation Inner Temp
16	AT-21	Local Oscillator Crystal A Temp	61	AT-33	Command Demodulator, VCO Temp
17	AT-22	Local Oscillator Crystal B Temp	62	AT-34	Power Distribution, Base Temp
18	AT-23	Transmitter A Crystal Temp	63	AT-35	Power Distribution, Internal Temp
19	AT-24	Transmitter A Heat Sink Temp	64	AT-36	PCU, Power Oscillator 1 Temp
20	AE-7	PCU Output Voltage 1 (29 V)	65	AE-10	PCU Output Voltage 4 (5 V)
21	AE-13	Receiver Prelimiting Level	66	AE-16	Transmitter B, R.F. Power
22	AE-18	Transmitter B Current	67	AR-5	RTG Cold Frame 2 Temp
23	AL-1	LP Amplifier Gain (X and Y)	68	AL-4	SP Amplifier Gain (Z)
24	AL-5	Leveling Mode and Coarse Sensor Mode	69	AL-8	Uncage Status
25	AB-6	D/P X On/Off Status	70	AI-1	SIDE LE Count Rate
26	AX-5	DTREM Cell 2 Output	71	AT-7	Thermal Plate Temp 5
27	AT-1	Sunshield Temp 1	72	AT-13	Insulation Outer Temp
28	AT-4	Thermal Plate Temp 2	73	BLANK	
29	AH-1	HFE Supply Voltage No. 1 (5 V)	74	AH-4	HFE Supply Voltage No. 4 (-15 V)
30	AX-2	DTREM Cell Temp	75	AH-7	HFE High Conductivity Htr Status
31	AT-25	Transmitter B Crystal Temp	76	AT-37	PCU, Power Oscillator 2 Temp
32	AT-26	Transmitter B Heat Sink Temp	77	AT-38	PCU, Regulator 1 Temp
33	AT-27	Analog DP, Base Temp	78	AT-39	PCU, Regulator 2 Temp
34	AT-28	Analog DP, Internal Temp	79	AE-11	PCU Output Voltage 5 (-12 V)
35	AE-8	PCU Output Voltage 2 (15 V)	80	AE-12	PCU Output Voltage 6 (-6 V)
36	AE-14	Receiver Local Oscillator Level	81	AE-17	Transmitter A Current
37	AR-2	RTG Hot Frame 2 Temp	82	AR-6	RTG Cold Frame 3 Temp
38	AL-2	LP Amplifier Gain (Z)	83	AX-1	DTREM Inner Temp
39	AL-6	Thermal Control Status	84	AX-4	DTREM Cell 1 Output
40	AE-6	Shunt Regulator 2 Current	85	AI-2	SIDE HE Count Rate
41	AX-6	DTREM Cell 3 Output	86	AZ-3	Timer Counter No. 2 Status
42	AT-2	Sunshield Temp 2	87	AT-9	Primary Structure Wall Temp 2 (Right)
43	AT-5	Thermal Plate Temp 3	88	AT-11	Primary Structure Wall Temp 3 (Back)
44	AE-5	Shunt Regulator 1 Current	89	BLANK	
45	AH-2	HFE Supply Voltage No. 2 (-5 V)	90	BLANK	

6-11

TABLE 6-VIII.- EXPERIMENT OFF DOWNLINK STATUS

The observed conditions with experiment operating power OFF and experiment standby power either OFF or ON, are as follows:

PSE	All 1's in the digital data words
LSM	All 1's in the digital data words
SWS	All 1's in the digital data words
SIDE	All 0's in the digital data words
HFE	All 1's in the digital data word

Central station housekeeping (90 channel mux, word 33)  
PSE Channels (AL-1 - AL-8), either 000 or 001  
SIDE Channels (AI-1 and AI-2), either 000 or 001  
HFE Channels (AH-1 - AH-7), either 000 or 001

With the experiments disconnected from the central station, all 1's are present in the digital data words. Open circuit channels to the analog multiplexer can read anywhere between 000 and 255 decimal PCM.

TABLE 6-IX.- ANALOG CHANNEL USAGE

CENTRAL STATION:

Symbol	Location/Name	Channel	Nominal Operating Limits		Nom Oper Value	Redline Limits	
			Low	High		Low	High
<u>Structural/Thermal Temperatures (Fahrenheit)</u>							
AT-1	Sunshield Temp 1	27	-245°	165°	-80°	-300°	300°
AT-2	Sunshield Temp 2	42	-245°	165°	-80°	-300°	300°
AT-3	Thermal Plate Temp 1	4	-20°	140°	83°	-25°	150°
AT-4	Thermal Plate Temp 2	28	-20°	140°	83°	-25°	150°
AT-5	Thermal Plate Temp 3	43	-20°	140°	83°	-25°	150°
AT-6	Thermal Plate Temp 4	58	-20°	140°	83°	-25°	150°
AT-7	Thermal Plate Temp 5	71	-20°	140°	83°	-25°	150°
AT-8	Primary Structure Wall Temp 1 (Left)	59	-210°	236°	0°	-300°	300°
AT-9	Primary Structure Wall Temp 2 (Right)	87	-210°	236°	0°	-300°	300°
AT-10	Primary Structure Bottom Temp 1	15	-210°	258°	6°	-300°	300°
AT-11	Primary Structure Wall Temp 3 (Back)	88	-300°	315°	28°	-300°	315°
AT-12	Insulation Inner Temp	60	-20°	157°	64°	-25°	167°
AT-13	Insulation Outer Temp	72	-135°	210°	26°	-300°	300°
<u>Electronic Temperatures (Fahrenheit)</u>							
AT-21	Local Oscillator Crystal A Temp***	16	-10°	140°	144°	-15°	170°
AT-22	Local Oscillator Crystal B Temp	17	0°	140°	75°	-15°	145°
AT-23	Transmitter A Crystal Temp	18	-10°	140°	75°	-15°	145°
AT-24	Transmitter A Heat Sink Temp	19	-10°	145°	75°	-15°	150°
AT-25	Transmitter B Crystal Temp***	31	-10°	140°	75°	-15°	145°
AT-26	Transmitter B Heat Sink Temp***	32	-10°	145°	75°	-15°	150°
AT-27	Analog D/P, Base Temp	33	-20°	140°	83°	-25°	150°
AT-28	Analog D/P, Internal Temp	34	-7°	130°	90°	-15°	163°
AT-29	Digital D/P, Base Temp	46	-10°	125°	83°	-25°	150°
AT-30	Digital D/P, Internal Temp	47	-12°	148°	87°	-20°	158°
AT-31	Command Decoder, Base Temp	48	-10°	140°	83°	-25°	150°
AT-32	Command Decoder, Internal Temp	49	-10°	145°	86°	-20°	155°
AT-33	Command Demodulator, VCO Temp	61	-10°	145°	86°	-20°	155°
AT-34	Power Distribution Unit, Base Temp	62	-10°	140°	83°	-25°	150°
AT-35	Power Distribution Unit, Internal Temp	63	10°	150°	100°	-10°	180°
AT-36	PCU, Power Oscillator 1 Temp	64	-10°	165°	94°	-20°	172°
AT-37	PCU, Power Oscillator 2 Temp	76	-10°	165°	94°	-20°	172°
AT-38	PCU, Regulator 1 Temp	77	-10°	195°	103°	-20°	210°
AT-39	PCU, Regulator 2 Temp	78	-10°	195°	103°	-20°	210°
<u>Central Station Electrical</u>							
AE-1	0.25 Vdc Calibration	2	.24V	.26V	.25V	.22V	.28V
AE-2	4.75 Vdc Calibration	3	4.72V	4.78V	4.75V	4.70V	4.80V
AE-3	Converter Input Voltage	1	15.4V	16.9V	16.2V	15.0V	17.5V
AE-4	Converter Input Current	5	3.9A	4.7A	4.2A	3.25A	4.8A
AE-5	Shunt Regulator 1 Current	8 & 44	0.3A	2.7A	1.1A	0.05A	3.18A
AE-6	Shunt Regulator 2 Current***	13 & 40	0.3A	2.7A	1.1A	0.05A	3.18A
AE-7	PCU Output Voltage 1 (29 V)	20	28.0V	30.0V	29.0V	27.5V	30.5V
AE-8	PCU Output Voltage 2 (15 V)	35	14.5V	15.6V	15.0V	14.2V	16.1V
AE-9	PCU Output Voltage 3 (12 V)	50	11.75V	12.25V	12.0V	11.0V	13.0V
AE-10	PCU Output Voltage 4 (5 V)	65	4.75V	5.3V	5.0V	4.0V	5.8V
AE-11	PCU Output Voltage 5 (-12 V)*	79	-12.75V	-11.9V	-12.0V	-12.9V	-11.8V
AE-12	PCU Output Voltage 6 (-6 V)*	80	-6.2V	-5.9V	-6.0V	-6.3V	-5.85V
AE-13**	Receiver, Prelimiting Level	21	-350dbm	-5 dbm	-88 dbm	-450 dbm	0 dbm
AE-14**	Receiver, Local Oscillator Level	36	4.5dbm	7.5dbm	6.1dbm	1.8dbm	7.6dbm
AE-15	Transmitter A, RF Power	51					
AE-16	Transmitter B, RF Power***	66					
AE-17**	Transmitter A Current	81					
AE-18**	Transmitter B Current***	22					

\*AE-11 and AE-12 values also vary with changes of PCU output voltage 1 (29V), AE-7.

\*\*Temperature dependent.

\*\*\*Redundant functions, not normally active.



TABLE 6-IX.- ANALOG CHANNEL USAGE - Concluded

Symbol	Location/Name	Channel	Nominal Operating Limits		Nom Oper Value	Redline Limits		
			Low	High		Low	High	
<u>RTG Temperatures (Fahrenheit)</u>								
AR-1	Hot Frame 1 Temp	6	1060°	1150°	1107°	980°	1160°	
AR-2	Hot Frame 2 Temp	37	1060°	1150°	1107°	980°	1160°	
AR-3	Hot Frame 3 Temp	52	1060°	1150°	1107°	980°	1160°	
AR-4	Cold Frame 1 Temp	7	415°	500°	450°	401°	500°	
AR-5	Cold Frame 2 Temp	67	400°	470°	430°	401°	500°	
AR-6	Cold Frame 3 Temp	82	415°	500°	450°	401°	500°	
<u>DTREM</u>								
AX-1	DTREM Inner Temp (Centigrade)	83	N/A	N/A	N/A	-150	135	
AX-2	DTREM Cell Temp (Centigrade)	30	37	125	110	37	125	
AX-3	DTREM Outer Temp (Centigrade)	56	N/A	N/A	N/A	-150	135	
AX-4	DTREM Cell 1 Output (No Filter)	84	0 mV	75 mV	65 mV	0 mV	75 mV	
AX-5	DTREM Cell 2 Output (Irradiated/Filter)	26	0 mV	75 mV	65 mV	0 mV	75 mV	
AX-6	DTREM Cell 3 Output (Filter)	41	0 mV	75 mV	65 mV	0 mV	75 mV	
Value in Decimal PCM								
AB-1	Command Demodulator 1 kHz Present	9	No modulation 0 to 76, no carrier 128 to 255 Modulation 77 to 127					
AB-4	Power Distribution Experiment 1 and 2 Standby Status	12	<u>Exper 1</u>		<u>Exper 2</u>			
			Standby-off	Standby-off	1 ± 1			
			Standby-on	Standby-off	72 ± 10			
			Standby-off	Standby-on	131 ± 10			
			Standby-on	Standby-on	192 ± 12			
AB-5	Power Distribution Experiment 3, 4, 5 Standby Status	14	<u>Exper 3</u>		<u>Exper 4</u>		<u>Exper 5</u>	
			Standby-off	Standby-off	Standby-off	1 ± 1		
			Standby-off	Standby-off	Standby-on	35 ± 10		
			Standby-off	Standby-on	Standby-off	69 ± 10		
			Standby-off	Standby-on	Standby-on	100 ± 10		
			Standby-on	Standby-off	Standby-off	131 ± 10		
			Standby-on	Standby-off	Standby-on	160 ± 10		
			Standby-on	Standby-on	Standby-off	188 ± 10		
			Standby-on	Standby-on	Standby-on	214 ± 10		
AB-6	Data Processor X On/Off Status	25	X processor on PCM > 128 X processor off PCM < 32					
AZ-1	Timer 18 Hr Status	10	0 to 18 hrs PCM < 32 } Alternates every 18 hours 18 to 36 hrs PCM > 128 }					
AZ-2	Timer Counter 1 Status	11	0 to 1-1/2 months PCM < 32 } Alternates every 1-1/2 1-1/2 to 3 months PCM > 128 } months					
AZ-3	Timer Counter 2 Status	86	0 to 1-1/2 months PCM < 32 } Alternates every 1-1/2 1-1/2 to 3 months PCM > 128 } months					

EXPERIMENTS:

Symbol	Location/Name	Channel	Nominal Operating Limits
<u>Passive Seismic</u>			
AL-1	LP Amplifier Gain (X and Y)	23	Discrete
AL-2	LP Amplifier Gain (Z)	38	Discrete
AD-3	Level Direction and Speed	53	Discrete
AL-4	SP Amplifier Gain (Z)	68	Discrete
AL-5	Leveling Mode and Coarse Sensor Mode	24	Discrete
AL-6	Thermal Control Status	39	Discrete
AL-7	Calibration Status LP and SP	54	Discrete
AL-8	Uncage Status	69	Discrete
<u>SIDE/CCGE</u>			
AI-1	LE Count Rate	70	0 to 1.4 x 10 <sup>6</sup> counts/second
AI-2	HE Count Rate	85	0 to 1.4 x 10 <sup>6</sup> counts/second
<u>Heat Flow</u>			
AH-1	Supply Voltage 1 (5 V)	29	4.9 to 5.1 Vdc
AH-2	Supply Voltage 2 (-5 V)	45	-4.9 to -5.1 Vdc
AH-3	Supply Voltage 3 (15 V)	55	14.7 to 15.3 Vdc
AH-4	Supply Voltage 4 (-15 V)	74	-14.7 to -15.3 Vdc
AH-5	Not Assigned		
AH-6	Low Cond Heater Power Status	57	Discrete
AH-7	High Cond Heater Power Status	75	Discrete

TABLE 6-X.- PSE MEASUREMENTS

Scientific Measurements

Symbol	Location/Measurement	ALSEP Word	ALSEP Frame	Sensor Range
DL- 1	Long Period X Seismic	9, 25, 41, 57	Every	1 mμ to 10μ
DL- 2	Long Period Y Seismic	11, 27, 43, 59	Every	1 mμ to 10μ
DL- 3	Long Period Z Seismic	13, 29, 45, 61	Every	1 mμ to 10μ
DL- 4	Long Period X Tidal	35	Even	±24 μradians
DL- 5	Long Period Y Tidal	37	Even	±24 μradians
DL- 6	Long Period Z Tidal	35	Odd	±4 mgal
DL- 7	Instrument Temp	37	Odd	107 - 143°F
DL- 8	Short Period Z Seismic	Every Even Word Except 2, 24, 46, 56	Every	1 mμ to 10μ

Engineering Measurements

8 channels of Engineering Measurements included in ALSEP Word 33

Symbol	Location/Measurement	Analog Channel	Sensor Range	Decimal PCM	
AL- 1	LP Ampl Gain (X and Y)	23	0 db	0-0.4V	0-21
			-10db	0.6-1.4	31-72
			-20db	1.6-2.4	82-122
			-30db	2.6-4.0	133-204
AL- 2	LP Ampl Gain (Z)	38	0 db	0-0.4V	0-21
			-10db	0.6-1.4	31-72
			-20db	1.6-2.4	82-122
			-30db	2.6-4.0	133-204
AL- 3	Level Direction and Speed	53	+low	0-0.4V	0-21
			-low	0.6-1.4	31-72
			+high	1.6-2.4	82-122
			-high	2.6-4.0	133-204
AL- 4	SP Ampl Gain (Z)	68	0 db	0-0.4V	0-21
			-10db	0.6-1.4	31-72
			-20db	1.6-2.4	82-122
			-30db	2.6-4.0	133-204
AL- 5	Leveling Mode and Coarse Sensor Mode	24	Automatic, coarse sensor out	0-0.4V	0-21
			Forced, coarse sensor out	0.6-1.4	31-72
			Automatic, coarse sensor in	1.6-2.4	82-122
			Forced, coarse sensor in	2.6-4.0	133-204
AL- 6	Thermal Control	39	Automatic Mode ON	0-0.4V	0-21
			Automatic Mode OFF	0.6-1.4	31-72
			Forced Mode ON	1.6-2.4	82-122
			Forced Mode OFF	2.6-4.0	133-204
AL- 7	Calibration Status LP & SP	54	All ON	0-0.4V	0-21
			LP - ON, SP - OFF	0.6-1.4	31-72
			LP - OFF, SP - ON	1.6-2.4	82-122
			All OFF	2.6-4.0	133-204
AL- 8	Uncage Status	69	Caged	0-0.4V	0-21
			Arm	0.6-1.4	31-72
			Uncage	1.6-2.4	82-122

TABLE 6-XI.-- LSM MEASUREMENTS

Scientific Measurements

Symbol	Location/Measurement	ALSEP Word	Frame	Range
DM-25	LSM X-Axis Field	17,49	Every	±50,±100,±200 gamma
DM-26	LSM Y-Axis Field	19,51	Every	±50,±100,±200 gamma
DM-27	LSM Z-Axis Field	21,53	Every	±50,±100,±200 gamma

These data are in Words 17, 19, 21, 49, 51, 53 and have the following format:

2 <sup>9</sup>	2 <sup>8</sup>	2 <sup>7</sup>	2 <sup>6</sup>	2 <sup>5</sup>	2 <sup>4</sup>	2 <sup>3</sup>	2 <sup>2</sup>	2 <sup>1</sup>	2 <sup>0</sup>
*Polarity Bit	Science Data								

\*0 = Plus 1, 1 = Minus

Engineering Measurements

Housekeeping is located in ALSEP Word 5 which is subcommutated over 16 frames as follows:

Bit in Word 5	2 <sup>9</sup>	2 <sup>8</sup>	2 <sup>7</sup>	2 <sup>6</sup>	2 <sup>5</sup>	2 <sup>4</sup>	2 <sup>3</sup>	2 <sup>2</sup>	2 <sup>1</sup>	2 <sup>0</sup>
Meaning	F	A1	A2	A3	A4	A5	A6	A7	B1	B2
		Engineering Data							Status Bits	

Where B1, B2 are bistable status data

A1, ....., A7 are bits derived from analog measurements

F locates the subcommutation start, F = 1 is Frame 1 of the subcommutation and F = 0 elsewhere.

Symbol	Location/Measurement	ALSEP Word	Frame	Sensor Range	
DM-1	Sensor X Temp	5	1,9	-30°C to +65°C	
DM-2	Sensor Y Temp	5	2,10	-30°C to +65°C	
DM-3	Sensor Z Temp	5	3,11	-30°C to +65°C	
DM-4	Base Temp	5	4,12	-30°C to +65°C	
DM-5	Internal Temp	5	5,13	-30°C to +65°C	
DM-6	Level Sensor 1	5	6,14	-15° to +15° (arc)	
DM-7	Level Sensor 2	5	7,15	-15° to +15° (arc)	
DM-8	Supply Voltage	5	8,16	0 to +6.25Vdc	
DM-9	X Flip Position	5	1	Discrete	2 status bits
DM-10	Y Flip Position	5	2	Discrete	2 status bits
DM-11	Z Flip Position	5	3	Discrete	2 status bits
DM-12	X Gimbal Position	5	4	Discrete	1 status bit
DM-13	Y Gimbal Position	5	4	Discrete	1 status bit
DM-14	Z Gimbal Position	5	5	Discrete	1 status bit
DM-15	Thermal Control State	5	5	Discrete	1 status bit
DM-16	Measurement Range	5	7	Discrete	2 status bits
DM-17	X Offset Field	5	9,10	Discrete	3 status bits
DM-18	Y Offset Field	5	10,11	Discrete	3 status bits
DM-19	Z Offset Field	5	12,13	Discrete	3 status bits
DM-20	Scientific/Calibrate Mode	5	13	Discrete	1 status bit
DM-21	Offset Axis Address	5	14	Discrete	2 status bits
DM-22	Filter ON/OFF Status	5	15	Discrete	1 status bit
DM-23	Flip/Cal inhibit Status	5	15	Discrete	1 status bit
DM-24	Filler Bits	5	16	Discrete	2 status bits
DM-28	Heater ON/OFF	5	6	Discrete	1 status bit
DM-29	Filler Bits	5	6,8	Discrete	3 status bits
DM-30	Frame Number	5	(Derived from F in Frame 1)		

TABLE 6-XII.- LSM 16 POINT ENGINEERING SUBCOMMUTATION FORMAT AND ENGINEERING STATUS  
BIT STRUCTURE LOCATED IN ALSEP MAIN FRAME, WORD 5

Frame Mark Bit	Engineering Parameter	Status Parameter	Subcommutation Frame	B <sub>1</sub>	B <sub>2</sub>	Status		
1	Sensor X Temp	X-axis Flip Position	1	0	0	Not at 0°, 90°, or 180° position		
		X-axis Flip Position	1	0	1	0° position		
		X-axis Flip Position	1	1	0	90° position		
		X-axis Flip Position	1	1	1	180° position		
0	Sensor Y Temp	Y-axis Flip Position	2	0	0	Not at 0°, 90°, or 180° position		
		Y-axis Flip Position	2	0	1	0° position		
		Y-axis Flip Position	2	1	0	90° position		
		Y-axis Flip Position	2	1	1	180° position		
0	Sensor Z Temp	Z-axis Flip Position	3	0	0	Not at 0°, 90°, or 180° position		
		Z-axis Flip Position	3	0	1	0° position		
		Z-axis Flip Position	3	1	0	90° position		
		Z-axis Flip Position	3	1	1	180° position		
0	Base Temp	X-axis Gimbal Position	4	1		Pre Site Survey Position		
		X-axis Gimbal Position	4	0		Post Site Survey Position		
		Y-axis Gimbal Position	4		1	Pre Site Survey Position		
		Y-axis Gimbal Position	4		0	Post Site Survey Position		
0	Internal Temp	Z-axis Gimbal Position	5	1		Pre Site Survey Position		
		Z-axis Gimbal Position	5	0		Post Site Survey Position		
		Temp Control State	5		1	X-axis Control		
		Temp Control State	5		0	Y-axis Control/OFF		
0	Level Sensor 1	Heater Power Status	6	1	1	Heater ON		
		Heater Power Status	6	1	0	Heater OFF		
0	Level Sensor 2	Measurement Range	7	0	0	50 y Range		
		Measurement Range	7	1	0	100 y Range		
		Measurement Range	7	1	1	200 y Range		
		Measurement Range	7	0	1	Error		
0	Supply Voltage 1	Filler Bits	8	1	1	Not used		
0	Sensor X Temp	X-axis Field Offset	9	0	1	0% offset		
0	Sensor Y Temp	X-axis Field Offset	10	1	1	0% offset		
		X-axis Field Offset	9	1	0	-25% offset		
		X-axis Field Offset	10	0		-25% offset		
		X-axis Field Offset	9	1	0	-50% offset		
		X-axis Field Offset	10	1		-50% offset		
		X-axis Field Offset	9	1	1	-75% offset		
		X-axis Field Offset	10	0		-75% offset		
		X-axis Field Offset	9	0	0	+75% offset		
		X-axis Field Offset	10	0		+75% offset		
		X-axis Field Offset	9	0	0	+50% offset		
		X-axis Field Offset	10	1		+50% offset		
		X-axis Field Offset	9	0	1	+25% offset		
		X-axis Field Offset	10	0		+25% offset		
		Y-axis Field Offset	10		0	0% offset		
		Y-axis Field Offset	11	1	1	0% offset		
		0	Sensor Z Temp	Y-axis Field Offset	10	1	1	-25% offset
0	Base Temp	Y-axis Field Offset	11	0	0	-25% offset		
		Y-axis Field Offset	10	1		-50% offset		
		Y-axis Field Offset	11	0	1	-50% offset		
		Y-axis Field Offset	10	0	1	-75% offset		
		Y-axis Field Offset	11	1	0	-75% offset		
		Y-axis Field Offset	10	0	0	+75% offset		
		Y-axis Field Offset	11	0	0	+75% offset		
		Y-axis Field Offset	10	0	0	+50% offset		
		Y-axis Field Offset	11	0	1	+50% offset		
		Y-axis Field Offset	10	0	0	+25% offset		
		Y-axis Field Offset	11	1	0	+25% offset		
		0	Internal Temp	Z-axis Field Offset	12	0	1	0% offset
		0	Internal Temp	Z-axis Field Offset	13	1	1	0% offset
				Z-axis Field Offset	12	0	0	-25% offset
				Z-axis Field Offset	13	0		-25% offset
				Z-axis Field Offset	12	1	0	-50% offset
Z-axis Field Offset	13			1		-50% offset		
Z-axis Field Offset	12			1	1	-75% offset		
Z-axis Field Offset	13			0		-75% offset		
Z-axis Field Offset	12			0	0	+75% offset		
Z-axis Field Offset	13			0		+75% offset		
Z-axis Field Offset	12			0	0	+50% offset		
Z-axis Field Offset	13			1		+50% offset		
Z-axis Field Offset	12			0	1	+25% offset		
Z-axis Field Offset	13			0		+25% offset		
0	Level Sensor 1			Offset Axis Address	14	0	0	Not at X, Y, or Z
0	Level Sensor 1			Offset Axis Address	14	1	0	X-axis position
				Offset Axis Address	14	0	1	Y-axis position
		Offset Axis Address	14	1	1	Z-axis position		
		Offset Axis Address	14	1	1	Z-axis position		
0	Level Sensor 2	Filter Status	15	1		Filter bypassed		
		Filter Status	15	0		Filter not bypassed		
		Flip/Cal Inhibit Status	15		1	Calibration Inhibited		
		Flip/Cal Inhibit Status	15		0	Calibration not inhibited		
0	Supply Voltage 1	Filler Bits	16	0	0	Not used		

NOTE: The SWS uses ALSEP Words 7, 23, 39 and 55 (in that order) to convey experiment data. The data is organized into 16 sequences of 186 words per sequence. Since the position of any element of data (Word) is indeterminate with respect to ALSEP Frames and Words, the channel designation is determined internally from information carried in the data. Therefore, in the following data, channel designation is not used but the data is identified by the SWS Word and by the first two bits (FB) which have been provided for Word identification within the sequence; and the sequence is identified by the Least Significant Bits (LSB) of Word 184 lying in the sequence being identified.

Basic Sequence, Repeated 16 times per cycle

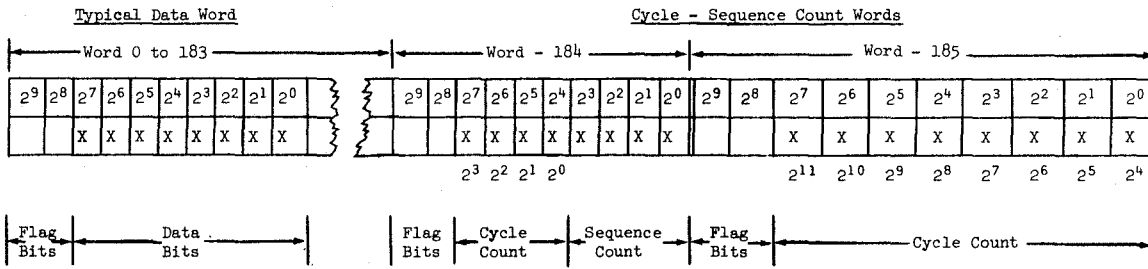
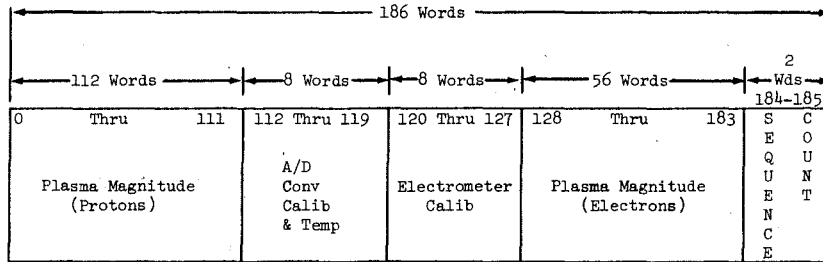

Flag Bits: 00 Scientific Data Word  
01 Calibration Data Word  
10 Sequence Counter Word

Figure 6-4.- SWS word format.

TABLE 6-XIII.- SWS MEASUREMENTS

SWS Sequences	Symbol	Location/Name	Flag Bit (FB)	SWS Word	Sensor Range
<u>Science Data</u>					
Plasma Magnitude (Positive Ions)					
Subcommutated as follows: a reading is made of the sum of the outputs of the 7 Faraday cups and then there are 7 consecutive readings of the individual Faraday cups. This set of 8 is repeated for 14 different settings of the analyzer plate voltage.					
<u>SWS Proton Flux</u>					
0-15; dc HiV Cal and ac HiV Cal in Sequence 14 and 15	DY- 1	Positive Ions - Sum - Lev 1	00	0	Log 0.4 to 6200 pA
	DY- 2	Positive Ions - Cup 1 - Lev 1	00	1	Log 0.4 to 6200 pA
	DY- 3	Positive Ions - Cup 2 - Lev 1	00	2	Log 0.4 to 6200 pA
	DY- 4	Positive Ions - Cup 3 - Lev 1	00	3	Log 0.4 to 6200 pA
	DY- 5	Positive Ions - Cup 4 - Lev 1	00	4	Log 0.4 to 6200 pA
	DY- 6	Positive Ions - Cup 5 - Lev 1	00	5	Log 0.4 to 6200 pA
	DY- 7	Positive Ions - Cup 6 - Lev 1	00	6	Log 0.4 to 6200 pA
	DY- 8	Positive Ions - Cup 7 - Lev 1	00	7	Log 0.4 to 6200 pA
	DY- 9	Positive Ions - Sum - Lev 2	00	8	Log 0.4 to 6200 pA
	DY-10	Positive Ions - Cup 1 - Lev 2	00	9	Log 0.4 to 6200 pA
	DY-11	Positive Ions - Cup 2 - Lev 2	00	10	Log 0.4 to 6200 pA
	DY-12	Positive Ions - Cup 3 - Lev 2	00	11	Log 0.4 to 6200 pA
	DY-13	Positive Ions - Cup 4 - Lev 2	00	12	Log 0.4 to 6200 pA
	DY-14	Positive Ions - Cup 5 - Lev 2	00	13	Log 0.4 to 6200 pA
	DY-15	Positive Ions - Cup 6 - Lev 2	00	14	Log 0.4 to 6200 pA
	DY-16	Positive Ions - Cup 7 - Lev 2	00	15	Log 0.4 to 6200 pA
	DY-17	Positive Ions - Sum - Lev 3	00	16	Log 0.4 to 6200 pA
	DY-18	Positive Ions - Cup 1 - Lev 3	00	17	Log 0.4 to 6200 pA
	DY-19	Positive Ions - Cup 2 - Lev 3	00	18	Log 0.4 to 6200 pA
	DY-20	Positive Ions - Cup 3 - Lev 3	00	19	Log 0.4 to 6200 pA
	DY-21	Positive Ions - Cup 4 - Lev 3	00	20	Log 0.4 to 6200 pA
	DY-22	Positive Ions - Cup 5 - Lev 3	00	21	Log 0.4 to 6200 pA
	DY-23	Positive Ions - Cup 6 - Lev 3	00	22	Log 0.4 to 6200 pA
	DY-24	Positive Ions - Cup 7 - Lev 3	00	23	Log 0.4 to 6200 pA
	DY-25	Positive Ions - Sum - Lev 4	00	24	Log 0.4 to 6200 pA
	DY-26	Positive Ions - Cup 1 - Lev 4	00	25	Log 0.4 to 6200 pA
	DY-27	Positive Ions - Cup 2 - Lev 4	00	26	Log 0.4 to 6200 pA
	DY-28	Positive Ions - Cup 3 - Lev 4	00	27	Log 0.4 to 6200 pA
	DY-29	Positive Ions - Cup 4 - Lev 4	00	28	Log 0.4 to 6200 pA
	DY-30	Positive Ions - Cup 5 - Lev 4	00	29	Log 0.4 to 6200 pA
	DY-31	Positive Ions - Cup 6 - Lev 4	00	30	Log 0.4 to 6200 pA
	DY-32	Positive Ions - Cup 7 - Lev 4	00	31	Log 0.4 to 6200 pA
	DY-33	Positive Ions - Sum - Lev 5	00	32	Log 0.4 to 6200 pA
	DY-34	Positive Ions - Cup 1 - Lev 5	00	33	Log 0.4 to 6200 pA
	DY-35	Positive Ions - Cup 2 - Lev 5	00	34	Log 0.4 to 6200 pA
	DY-36	Positive Ions - Cup 3 - Lev 5	00	35	Log 0.4 to 6200 pA
	DY-37	Positive Ions - Cup 4 - Lev 5	00	36	Log 0.4 to 6200 pA
	DY-38	Positive Ions - Cup 5 - Lev 5	00	37	Log 0.4 to 6200 pA
	DY-39	Positive Ions - Cup 6 - Lev 5	00	38	Log 0.4 to 6200 pA
	DY-40	Positive Ions - Cup 7 - Lev 5	00	39	Log 0.4 to 6200 pA
	DY-41	Positive Ions - Sum - Lev 6	00	40	Log 0.4 to 6200 pA
	DY-42	Positive Ions - Cup 1 - Lev 6	00	41	Log 0.4 to 6200 pA
	DY-43	Positive Ions - Cup 2 - Lev 6	00	42	Log 0.4 to 6200 pA
	DY-44	Positive Ions - Cup 3 - Lev 6	00	43	Log 0.4 to 6200 pA
	DY-45	Positive Ions - Cup 4 - Lev 6	00	44	Log 0.4 to 6200 pA
	DY-46	Positive Ions - Cup 5 - Lev 6	00	45	Log 0.4 to 6200 pA
	DY-47	Positive Ions - Cup 6 - Lev 6	00	46	Log 0.4 to 6200 pA
	DY-48	Positive Ions - Cup 7 - Lev 6	00	47	Log 0.4 to 6200 pA
	DY-49	Positive Ions - Sum - Lev 7	00	48	Log 0.4 to 6200 pA
	DY-50	Positive Ions - Cup 1 - Lev 7	00	49	Log 0.4 to 6200 pA
	DY-51	Positive Ions - Cup 2 - Lev 7	00	50	Log 0.4 to 6200 pA
	DY-52	Positive Ions - Cup 3 - Lev 7	00	51	Log 0.4 to 6200 pA
	DY-53	Positive Ions - Cup 4 - Lev 7	00	52	Log 0.4 to 6200 pA
	DY-54	Positive Ions - Cup 5 - Lev 7	00	53	Log 0.4 to 6200 pA
	DY-55	Positive Ions - Cup 6 - Lev 7	00	54	Log 0.4 to 6200 pA
	DY-56	Positive Ions - Cup 7 - Lev 7	00	55	Log 0.4 to 6200 pA
	DY-57	Positive Ions - Sum - Lev 8	00	56	Log 0.4 to 6200 pA
	DY-58	Positive Ions - Cup 1 - Lev 8	00	57	Log 0.4 to 6200 pA
	DY-59	Positive Ions - Cup 2 - Lev 8	00	58	Log 0.4 to 6200 pA
	DY-60	Positive Ions - Cup 3 - Lev 8	00	59	Log 0.4 to 6200 pA
	DY-61	Positive Ions - Cup 4 - Lev 8	00	60	Log 0.4 to 6200 pA

TABLE 6-XIII.- SWS MEASUREMENTS - Continued

SWS Sequences	Symbol	Location/Name	Flag Bit (FB)	SWS Word	Sensor Range	
0-15; dc HiV Cal and ac HiV Cal in Sequence 14 and 15	DY-62	Positive Ions - Cup 5 - Lev 8	00	61	Log 0.4 to 6200 pA	
	DY-63	Positive Ions - Cup 6 - Lev 8	00	62	Log 0.4 to 6200 pA	
	DY-64	Positive Ions - Cup 7 - Lev 8	00	63	Log 0.4 to 6200 pA	
	DY-65	Positive Ions - Sum - Lev 9	00	64	Log 0.4 to 6200 pA	
	DY-66	Positive Ions - Cup 1 - Lev 9	00	65	Log 0.4 to 6200 pA	
	DY-67	Positive Ions - Cup 2 - Lev 9	00	66	Log 0.4 to 6200 pA	
	DY-68	Positive Ions - Cup 3 - Lev 9	00	67	Log 0.4 to 6200 pA	
	DY-69	Positive Ions - Cup 4 - Lev 9	00	68	Log 0.4 to 6200 pA	
	DY-70	Positive Ions - Cup 5 - Lev 9	00	69	Log 0.4 to 6200 pA	
	DY-71	Positive Ions - Cup 6 - Lev 9	00	70	Log 0.4 to 6200 pA	
	DY-72	Positive Ions - Cup 7 - Lev 9	00	71	Log 0.4 to 6200 pA	
	DY-73	Positive Ions - Sum - Lev 10	00	72	Log 0.4 to 6200 pA	
	DY-74	Positive Ions - Cup 1 - Lev 10	00	73	Log 0.4 to 6200 pA	
	DU-75	Positive Ions - Cup 2 - Lev 10	00	74	Log 0.4 to 6200 pA	
	DY-76	Positive Ions - Cup 3 - Lev 10	00	75	Log 0.4 to 6200 pA	
	DY-77	Positive Ions - Cup 4 - Lev 10	00	76	Log 0.4 to 6200 pA	
	DY-78	Positive Ions - Cup 5 - Lev 10	00	77	Log 0.4 to 6200 pA	
	DY-79	Positive Ions - Cup 6 - Lev 10	00	78	Log 0.4 to 6200 pA	
	DY-80	Positive Ions - Cup 7 - Lev 10	00	79	Log 0.4 to 6200 pA	
	DY-81	Positive Ions - Sum - Lev 11	00	80	Log 0.4 to 6200 pA	
	DY-82	Positive Ions - Cup 1 - Lev 11	00	81	Log 0.4 to 6200 pA	
	DY-83	Positive Ions - Cup 2 - Lev 11	00	82	Log 0.4 to 6200 pA	
	DY-84	Positive Ions - Cup 3 - Lev 11	00	83	Log 0.4 to 6200 pA	
	DY-85	Positive Ions - Cup 4 - Lev 11	00	84	Log 0.4 to 6200 pA	
	DY-86	Positive Ions - Cup 5 - Lev 11	00	85	Log 0.4 to 6200 pA	
	DY-87	Positive Ions - Cup 6 - Lev 11	00	86	Log 0.4 to 6200 pA	
	DY-88	Positive Ions - Cup 7 - Lev 11	00	87	Log 0.4 to 6200 pA	
	DY-89	Positive Ions - Sum - Lev 12	00	88	Log 0.4 to 6200 pA	
	DY-90	Positive Ions - Cup 1 - Lev 12	00	89	Log 0.4 to 6200 pA	
	DY-91	Positive Ions - Cup 2 - Lev 12	00	90	Log 0.4 to 6200 pA	
	DY-92	Positive Ions - Cup 3 - Lev 12	00	91	Log 0.4 to 6200 pA	
	DY-93	Positive Ions - Cup 4 - Lev 12	00	92	Log 0.4 to 6200 pA	
	DY-94	Positive Ions - Cup 5 - Lev 12	00	93	Log 0.4 to 6200 pA	
	DY-95	Positive Ions - Cup 6 - Lev 12	00	94	Log 0.4 to 6200 pA	
	DY-96	Positive Ions - Cup 7 - Lev 12	00	95	Log 0.4 to 6200 pA	
	DZ- 1	Positive Ions - Sum - Lev 13	00	96	Log 0.4 to 6200 pA	
	DZ- 2	Positive Ions - Cup 1 - Lev 13	00	97	Log 0.4 to 6200 pA	
	DZ- 3	Positive Ions - Cup 2 - Lev 13	00	98	Log 0.4 to 6200 pA	
	DZ- 4	Positive Ions - Cup 3 - Lev 13	00	99	Log 0.4 to 6200 pA	
	DZ- 5	Positive Ions - Cup 4 - Lev 13	00	100	Log 0.4 to 6200 pA	
	DZ- 6	Positive Ions - Cup 5 - Lev 13	00	101	Log 0.4 to 6200 pA	
	DZ- 7	Positive Ions - Cup 6 - Lev 13	00	102	Log 0.4 to 6200 pA	
	DZ- 8	Positive Ions - Cup 7 - Lev 13	00	103	Log 0.4 to 6200 pA	
	DZ- 9	Positive Ions - Sum - Lev 14	00	104	Log 0.4 to 6200 pA	
	DZ-10	Positive Ions - Cup 1 - Lev 14	00	105	Log 0.4 to 6200 pA	
	DZ-11	Positive Ions - Cup 2 - Lev 14	00	106	Log 0.4 to 6200 pA	
	DZ-12	Positive Ions - Cup 3 - Lev 14	00	107	Log 0.4 to 6200 pA	
	DZ-13	Positive Ions - Cup 4 - Lev 14	00	108	Log 0.4 to 6200 pA	
	DZ-14	Positive Ions - Cup 5 - Lev 14	00	109	Log 0.4 to 6200 pA	
	DZ-15	Positive Ions - Cup 6 - Lev 14	00	110	Log 0.4 to 6200 pA	
	DZ-16	Positive Ions - Cup 7 - Lev 14	00	111	Log 0.4 to 6200 pA	
			Plasma Magnitude (Electrons)		128-183	Log 0.4 to 6200 pA
			Subcommutated in a manner similar to above except that here the set of 8 is repeated for 7 different settings of the analyzer plate voltage.			
			<u>SWS Electron Flux</u>			
	DZ-17		Electrons - Sum - Lev 15	00	128	Log 0.4 to 6200 pA
	DZ-18		Electrons - Cup 1 - Lev 15	00	129	Log 0.4 to 6200 pA
	DZ-19		Electrons - Cup 2 - Lev 15	00	130	Log 0.4 to 6200 pA
	DZ-20		Electrons - Cup 3 - Lev 15	00	131	Log 0.4 to 6200 pA
	DZ-21		Electrons - Cup 4 - Lev 15	00	132	Log 0.4 to 6200 pA
	DZ-22		Electrons - Cup 5 - Lev 15	00	133	Log 0.4 to 6200 pA
	DZ-23		Electrons - Cup 6 - Lev 15	00	134	Log 0.4 to 6200 pA
	DZ-24		Electrons - Cup 7 - Lev 15	00	135	Log 0.4 to 6200 pA
	DZ-25		Electrons - Sum - Lev 16	00	136	Log 0.4 to 6200 pA
	DZ-26		Electrons - Cup 1 - Lev 16	00	137	Log 0.4 to 6200 pA

TABLE 6-XIII.-- SWS MEASUREMENTS - Continued

SWS Sequences	Symbol	Location/Name	Flag Bit (FB)	SWS Word	Sensor Range
0-15; dc	DZ-27	Electrons - Cup 2 - Lev 16	00	138	Log 0.4 to 6200 pA
HiV Cal and	DZ-28	Electrons - Cup 3 - Lev 16	00	139	Log 0.4 to 6200 pA
ac HiV Cal	DZ-29	Electrons - Cup 4 - Lev 16	00	140	Log 0.4 to 6200 pA
in Sequence	DZ-30	Electrons - Cup 5 - Lev 16	00	141	Log 0.4 to 6200 pA
14 and 15	DZ-31	Electrons - Cup 6 - Lev 16	00	142	Log 0.4 to 6200 pA
	DZ-32	Electrons - Cup 7 - Lev 16	00	143	Log 0.4 to 6200 pA
	DZ-33	Electrons - Sum - Lev 17	00	144	Log 0.4 to 6200 pA
	DZ-34	Electrons - Cup 1 - Lev 17	00	145	Log 0.4 to 6200 pA
	DZ-35	Electrons - Cup 2 - Lev 17	00	146	Log 0.4 to 6200 pA
	DZ-36	Electrons - Cup 3 - Lev 17	00	147	Log 0.4 to 6200 pA
	DZ-37	Electrons - Cup 4 - Lev 17	00	148	Log 0.4 to 6200 pA
	DZ-38	Electrons - Cup 5 - Lev 17	00	149	Log 0.4 to 6200 pA
	DZ-39	Electrons - Cup 6 - Lev 17	00	150	Log 0.4 to 6200 pA
	DZ-40	Electrons - Cup 7 - Lev 17	00	151	Log 0.4 to 6200 pA
	DZ-41	Electrons - Sum - Lev 18	00	152	Log 0.4 to 6200 pA
	DZ-42	Electrons - Cup 1 - Lev 18	00	153	Log 0.4 to 6200 pA
	DZ-43	Electrons - Cup 2 - Lev 18	00	154	Log 0.4 to 6200 pA
	DZ-44	Electrons - Cup 3 - Lev 18	00	155	Log 0.4 to 6200 pA
	DZ-45	Electrons - Cup 4 - Lev 18	00	156	Log 0.4 to 6200 pA
	DZ-46	Electrons - Cup 5 - Lev 18	00	157	Log 0.4 to 6200 pA
	DZ-47	Electrons - Cup 6 - Lev 18	00	158	Log 0.4 to 6200 pA
	DZ-48	Electrons - Cup 7 - Lev 18	00	159	Log 0.4 to 6200 pA
	DZ-49	Electrons - Sum - Lev 19	00	160	Log 0.4 to 6200 pA
	DZ-50	Electrons - Cup 1 - Lev 19	00	161	Log 0.4 to 6200 pA
	DZ-51	Electrons - Cup 2 - Lev 19	00	162	Log 0.4 to 6200 pA
	DZ-52	Electrons - Cup 3 - Lev 19	00	163	Log 0.4 to 6200 pA
	DZ-53	Electrons - Cup 4 - Lev 19	00	164	Log 0.4 to 6200 pA
	DZ-54	Electrons - Cup 5 - Lev 19	00	165	Log 0.4 to 6200 pA
	DZ-55	Electrons - Cup 6 - Lev 19	00	166	Log 0.4 to 6200 pA
	DZ-56	Electrons - Cup 7 - Lev 19	00	167	Log 0.4 to 6200 pA
	DZ-57	Electrons - Sum - Lev 20	00	168	Log 0.4 to 6200 pA
	DZ-58	Electrons - Cup 1 - Lev 20	00	169	Log 0.4 to 6200 pA
	DZ-59	Electrons - Cup 2 - Lev 20	00	170	Log 0.4 to 6200 pA
	DZ-60	Electrons - Cup 3 - Lev 20	00	171	Log 0.4 to 6200 pA
	DZ-61	Electrons - Cup 4 - Lev 20	00	172	Log 0.4 to 6200 pA
	DZ-62	Electrons - Cup 5 - Lev 20	00	173	Log 0.4 to 6200 pA
	DZ-63	Electrons - Cup 6 - Lev 20	00	174	Log 0.4 to 6200 pA
	DZ-64	Electrons - Cup 7 - Lev 20	00	175	Log 0.4 to 6200 pA
	DZ-65	Electrons - Sum - Lev 21	00	176	Log 0.4 to 6200 pA
	DZ-66	Electrons - Cup 1 - Lev 21	00	177	Log 0.4 to 6200 pA
	DZ-67	Electrons - Cup 2 - Lev 21	00	178	Log 0.4 to 6200 pA
	DZ-68	Electrons - Cup 3 - Lev 21	00	179	Log 0.4 to 6200 pA
	DZ-69	Electrons - Cup 4 - Lev 21	00	180	Log 0.4 to 6200 pA
	DZ-70	Electrons - Cup 5 - Lev 21	00	181	Log 0.4 to 6200 pA
	DZ-71	Electrons - Cup 6 - Lev 21	00	182	Log 0.4 to 6200 pA
	DZ-72	Electrons - Cup 7 - Lev 21	00	183	Log 0.4 to 6200 pA



TABLE 6-XIII.- SWS MEASUREMENTS - Continued

SWS Sequence	Symbol	Location/Name	Flag Bit (FB)	SWS Word	LSB's Word 184	Sensor Range
<u>Engineering Data</u>						
<u>Sequence Counter</u>						
0-15	{ DW- 1	LSB (1 bit per sequence)	10	184	All	0-256
	{ DW- 2	MSB (1 bit per 256 sequences)	10	185	All	0-256
<u>A/D Converter Calibration, Repeated Every Other SWS Sequence</u>						
0						
2						
4	DW- 3	9 mV + 2%	01	112, 117	0	Log 0.6 to 10,000 mV
6	DW- 4	90 mV + 2%	01	113	0	Log 0.6 to 10,000 mV
8	DW- 5	900 mV + 2%	01	114, 118	0	Log 0.6 to 10,000 mV
10	DW- 6	3000 mV + 2%	01	115	0	Log 0.6 to 10,000 mV
12	DW- 7	9000 mV + 2%	01	116, 119	0	Log 0.6 to 10,000 mV
14						
1	DW-11	Temperature Sensor Mod 100	01	112	1	-50 to +150°C
3	DW-12	Temperature Sensor Mod 200	01	113	1	-50 to +150°C
5	DW-13	Temperature Sensor Mod 300	01	114	1	-50 to +150°C
7	DW-14	Temperature Sensor Cup Assembly	01	115	1	-185 to +150°C
9	DW-15	Sun Angle Sensor	01	116	1	One Value
11	DW-16	Programer Voltage	01	117	1	0 to 9 V
13	DW-17	Step Generator Voltage	01	118	1	0 to 9 V
15	DW-18	Modulation Monitor	01	119	1	PCM counts
<u>Current Calibrate, Repeated Every Fourth SWS Sequence</u>						
<u>PCM Count</u>						
0 4 8 12  1 5 9 13  2 6 10 14  3 7 11 15	{ DW-19	0 Ampere	01	120	00	014 + 6
	{ DW-20	0 Ampere Cup 1	01	121	00	016 + 4
	{ DW-21	0 Ampere Cup 2	01	122	00	016 + 4
	{ DW-22	0 Ampere Cup 3	01	123	00	016 + 4
	{ DW-23	0 Ampere Cup 4	01	124	00	016 + 4
	{ DW-24	0 Ampere Cup 5	01	125	00	016 + 4
	{ DW-25	0 Ampere Cup 6	01	126	00	016 + 4
	{ DW-26	0 Ampere Cup 7	01	127	00	016 + 4
	{ DW-27	7x5.76x10 <sup>-12</sup> Ampere	01	120	01	037 + 6
	{ DW-28	5.76x10 <sup>-12</sup> Ampere Cup 1	01	121	01	019 + 4
	{ DW-29	5.76x10 <sup>-12</sup> Ampere Cup 2	01	122	01	019 + 4
	{ DW-30	5.76x10 <sup>-12</sup> Ampere Cup 3	01	123	01	019 + 4
	{ DW-31	5.76x10 <sup>-12</sup> Ampere Cup 4	01	124	01	019 + 4
	{ DW-32	5.76x10 <sup>-12</sup> Ampere Cup 5	01	125	01	019 + 4
	{ DW-33	5.76x10 <sup>-12</sup> Ampere Cup 6	01	126	01	019 + 4
	{ DW-34	5.76x10 <sup>-12</sup> Ampere Cup 7	01	127	01	019 + 4
	{ DW-35	7x5.76x10 <sup>-11</sup> Ampere	01	120	10	119 + 4
	{ DW-36	5.76x10 <sup>-11</sup> Ampere Cup 1	01	121	10	050 + 4
	{ DW-37	5.76x10 <sup>-11</sup> Ampere Cup 2	01	122	10	050 + 4
	{ DW-38	5.76x10 <sup>-11</sup> Ampere Cup 3	01	123	10	050 + 4
	{ DW-39	5.76x10 <sup>-11</sup> Ampere Cup 4	01	124	10	050 + 4
	{ DW-40	5.76x10 <sup>-11</sup> Ampere Cup 5	01	125	10	050 + 4
	{ DW-41	5.76x10 <sup>-11</sup> Ampere Cup 6	01	126	10	050 + 4
	{ DW-42	5.76x10 <sup>-11</sup> Ampere Cup 7	01	127	10	050 + 4
	{ DW-43	7x5.76x10 <sup>-9</sup> Ampere	01	120	11	254 + 1
	{ DW-44	5.76x10 <sup>-9</sup> Ampere Cup 1	01	121	11	246 + 3
	{ DW-45	5.76x10 <sup>-9</sup> Ampere Cup 2	01	122	11	246 + 3
{ DW-46	5.76x10 <sup>-9</sup> Ampere Cup 3	01	123	11	246 + 3	
{ DW-47	5.76x10 <sup>-9</sup> Ampere Cup 4	01	124	11	246 + 3	
{ DW-48	5.76x10 <sup>-9</sup> Ampere Cup 5	01	125	11	246 + 3	
{ DW-49	5.76x10 <sup>-9</sup> Ampere Cup 6	01	126	11	246 + 3	
{ DW-50	5.76x10 <sup>-9</sup> Ampere Cup 7	01	127	11	246 + 3	
<u>dc HiV Calibrate, Repeated Once Every 16 SWS Sequences</u>						
<u>PCM Count</u>						
						<u>Low Gain</u>
						<u>High Gain</u>
14	{ DW-51	Level #1 (Proton)	01	0	1110	11 + 10
	{ DW-52	Level #2	01	8	1110	13 + 7
	{ DW-53	Level #3	01	16	1110	31 + 5
	{ DW-54	Level #4	01	24	1110	51 + 4

TABLE 6-XIII.- SWS MEASUREMENTS - Concluded

SWS Sequences	Symbol	Location/Name	Flag Bit (FB)	SWS Word	LSB's Word 184	PCM Count	
						Low Gain	High Gain
14	DW-55	Level #5	01	32	1110	68 ± 4	95 ± 4
	DW-56	Level #6	01	40	1110	86 ± 4	112 ± 4
	DW-57	Level #7	01	48	1110	103 ± 4	130 ± 4
	DW-58	Level #8	01	56	1110	119 ± 4	163 ± 4
	DW-59	Level #9	01	64	1110	136 ± 4	163 ± 4
	DW-60	Level #10	01	72	1110	153 ± 4	180 ± 4
	DW-61	Level #11	01	80	1110	170 ± 4	197 ± 4
	DW-62	Level #12	01	88	1110	188 ± 4	215 ± 4
	DW-63	Level #13	01	96	1110	205 ± 4	231 ± 4
	DW-64	Level #14	01	104	1110	223 ± 4	247 ± 4
	DW-65	Level #15 (Electron)	01	128	1110	016 ± 10	047 ± 10
	DW-66	Level #16	01	136	1110	046 ± 7	075 ± 7
	DW-67	Level #17	01	144	1110	082 ± 5	110 ± 5
	DW-68	Level #18	01	152	1110	117 ± 4	144 ± 4
	DW-69	Level #19	01	160	1110	152 ± 4	178 ± 4
	DW-70	Level #20	01	168	1110	187 ± 4	214 ± 4
DW-71	Level #21	01	176	1110	222 ± 4	250 ± 4	
as HiV Calibrate, Repeated Once Every 16 SWS Sequences							
15	DW-72	Level #1 (Proton)	01	0	1111	031 ± 3	052 ± 3
	DW-73	Level #2	01	8	1111	044 ± 3	064 ± 3
	DW-74	Level #3	01	16	1111	055 ± 3	076 ± 3
	DW-75	Level #4	01	24	1111	069 ± 3	090 ± 3
	DW-76	Level #5	01	32	1111	082 ± 3	104 ± 3
	DW-77	Level #6	01	40	1111	095 ± 3	119 ± 3
	DW-78	Level #7	01	48	1111	111 ± 3	135 ± 3
	DW-79	Level #8	01	56	1111	126 ± 3	150 ± 3
	DW-80	Level #9	01	64	1111	141 ± 3	166 ± 3
	DW-81	Level #10	01	72	1111	157 ± 3	182 ± 3
	DW-82	Level #11	01	80	1111	173 ± 3	199 ± 3
	DW-83	Level #12	01	88	1111	190 ± 3	217 ± 3
	DW-84	Level #13	01	96	1111	207 ± 3	233 ± 3
	DW-85	Level #14	01	104	1111	224 ± 3	248 ± 3
	DW-86	Level #15 (Electron)	01	128	1111	038 ± 3	058 ± 3
	DW-87	Level #16	01	136	1111	063 ± 3	086 ± 3
DW-88	Level #17	01	144	1111	092 ± 3	116 ± 3	
DW-89	Level #18	01	152	1111	123 ± 3	148 ± 3	
DW-90	Level #19	01	160	1111	155 ± 3	181 ± 3	
DW-91	Level #20	01	168	1111	189 ± 3	215 ± 3	
DW-92	Level #21	01	176	1111	224 ± 3	249 ± 3	

TABLE 6-XIV.- LIMITS OF SWS ENGINEERING DATA

Symbol	Location/Name	Red Line Low	Nominal Low	Nominal	Nominal High	Redline High
DW-3	9mV A/D Calibration	1mV	8mV	9mV	10mV	20mV
DW-4	90mV A/D Calibration	50mV	80mV	90mV	100mV	150mV
DW-5	900mV A/D Calibration	500mV	800mV	900mV	1000mV	1500mV
DW-6	3000mV A/D Calibration	1650mV	2650mV	3000mV	3300mV	5000mV
DW-7	9000mV A/D Calibration	5000mV	8000mV	9000mV	9800mV	10,500mV
DW-11	Temperature, Mod 100	-25°C	-10°C	+25°C	+80°C	+100°C
DW-12	Temperature, Mod 200	-25°C	-10°C	+25°C	+80°C	+100°C
DW-13	Temperature, Mod 300	-25°C	-10°C	+25°C	+80°C	+100°C
DW-14	Temperature, Sensor Cup Assembly	-150°C	-101°C	+25°C	+93°C	+120°C
DW-15	Sun Angle Sensor	-1V	-.1V	0V	5.0V	9.8V
DW-16	Programmer Voltage	4.0V	4.6V	4.95V	5.1V	6.0V
DW-17	Step Generator Voltage	.60V	.85V	.88V	.91V	1.2V
DW-18	Modulation Monitor	120 PCM	144 PCM	152 PCM	158 PCM	187 PCM

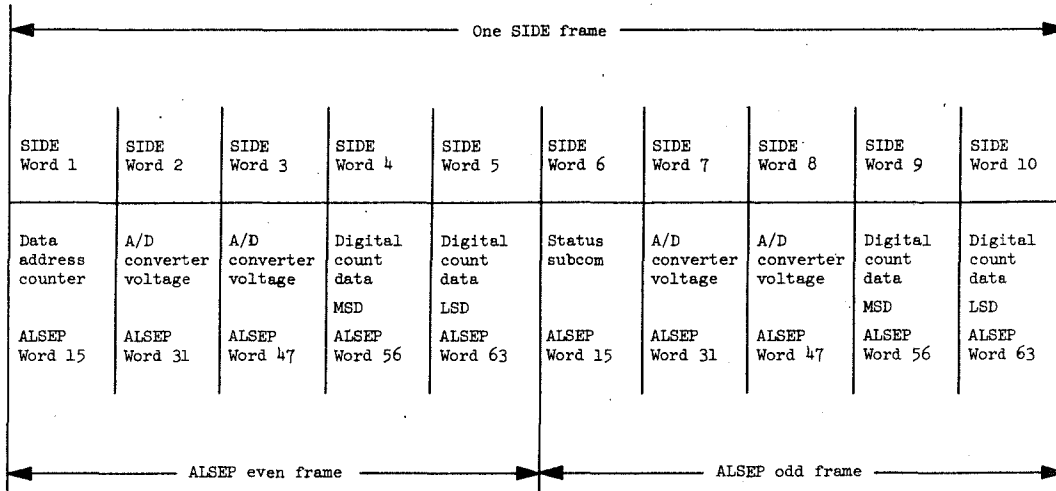

- SIDE Word 1 - Provides identification of selected step in measurement program (SIDE frame count), a parity check of SIDE data in previous ALSEP frame, and even frame identification
- Word 2 - CCGE data and housekeeping data, subcommutated
- Word 3 - Voltage on high-energy curved-plate analyzer
- Word 4 and Word 5 - Count data from high-energy curved-plate analyzer
- Word 6 - Various data subcommutated, such as command mode, command waiting for execution, range of electrometer, and ground plane grid voltage step; also, parity check of SIDE data in previous ALSEP frame and odd frame identification
- Word 7 - Velocity filter voltage
- Word 8 - Voltage on low-energy curved-plate analyzer
- Word 9 and Word 10 - Count data from low-energy curved-plate analyzer

Figure 6-5.- SIDE word format.

TABLE 6-XV.- SIDE/CCGE MEASUREMENTS

Symbol	Location/Name	SIDE Frames	Sensor Range
Following measurements carried in ALSEP Word 15 even, SIDE Word 1 and in indicated SIDE Frames.			
DI-1	*SIDE Frame Counter	All	0-127 *7 bits 4 to 10 inclusive
Following measurements carried in ALSEP Word 31 even, SIDE Word 2 and in indicated SIDE Frames.			
DI-2	+5 volts analog	0,32,64,96	5 V ± 0.15 V
DI-3	CCGE Science Data	1,3,5,7,9,41,73,105,121-127	
DI-4	Temp 1 (CCIG)	2,34,66,98	100 to 400°K
DI-5	Temp 2 (200 Blivet)	4,36,68,100	-90 to +125°C
DI-6	Temp 3 (500 Blivet)	6,38,70,102	-90 to +125°C
DI-7	4.5 kV	8,40,72,104	3.72 to 5.45 kV
DI-8	CCGE Range	10,24,42,56,74,88,106,120	Range 1 6.9 to 9.0 V Range 2 4.2 to 5.7 V Range 3 2.2 to 3.2 V
DI-9	Temp 4 (100 Blivet)	11,43,75,107	-50 to +90°C
DI-10	Temp 5 (300 Blivet)	12,44,76,108	-50 to +90°C
DI-11	GND Plane voltage	13,15,29,31,45,47,61,63,69 77,79,93,95,109,111	
DI-12	Solar Cell	14,78	15 mV to 600 mV
DI-13	+60 volts	16,48,80,112	.15 to 150 V
DI-14	+30 volts	17,49,81,113	.15 to 150 V
DI-15	+5 volts digital	18,50,82,114	15 mV to 15 V
DI-16	Ground	19,51,83,115	0 to 18 mV
DI-17	-5 volts	20,52,84,116	-15 mV to -15 V
DI-18	-30 volts	21,53,85,117	-.15 to -150 V
DI-19	Temp 6 (800 Blivet)	22,54,86,118	-50 to +90°C
DI-20	-3.5 kV	23,55,87,119	-2.9 to -4.25 kV
DI-21	+1.0 volt cal.	27,59,91	15 mV to 15 V
DI-22	+30 mV cal.	25,57,89	15 mV to 15 V
DI-23	+A/D Ref. voltage	26,58,90	15 mV to 15 V
DI-24	Dust Cover and Seal	67,71	Preset 3.125 to 5.5 V Seal Only 1.875 to 3.125 Dust Cover Only .625 to 1.875 Cover and Seal 0 to .625
DI-25	-A/D Ref. volt	30,62,94	-15 mV to -15 V
DI-26	-1.0 volt cal.	37,101	-15 mV to -15 V
DI-27	-12 volt cal.	39,103	-15 mV to -15 V
DI-28	+12 volt cal.	28,60,92	15 mV to 15 V
DI-29	Pre Reg Duty Factor	65	68% to 100%
DI-30	-30 mV cal.	46,110	-15 mV to -15 V
DF-29	One Time Command Register Status	33,35,97,99	Preset 0 to .625V Seal Only .625 to 1.875V Dust Cover 1.875 to 3.125V Dust Cover and Seal 3.125 to 5.5V

\*See note on Page 6-27 for measurement content.

TABLE XV.- SIDE/COGE MEASUREMENTS - Continued

Symbol	Location/Name	SIDE Frame	Nominal Value
Following measurements carried in ALSEP Word 47 even, SIDE Word 3 and in indicated SIDE Frames.			
			<u>Voltage</u>
DI-40	HECPA Stepper Voltage	1,21,41,61,81,101	+437.5V
DI-41	HECPA Stepper Voltage	2,22,42,62,82,102	406.25V
DI-42	HECPA Stepper Voltage	3,23,43,63,83,103	375.0V
DI-43	HECPA Stepper Voltage	4,24,44,64,84,104	343.75V
DI-44	HECPA Stepper Voltage	5,25,45,65,85,105	312.5V
DI-45	HECPA Stepper Voltage	6,26,46,66,86,106	281.25V
DI-46	HECPA Stepper Voltage	7,27,47,67,87,107	250.0V
DI-47	HECPA Stepper Voltage	8,28,48,68,88,108	218.75V
DI-48	HECPA Stepper Voltage	9,29,49,69,89,109	187.5V
DI-49	HECPA Stepper Voltage	10,30,50,70,90,110	156.25V
DI-50	HECPA Stepper Voltage	11,31,51,71,91,111	125.0V
DI-51	HECPA Stepper Voltage	12,32,52,72,92,112	93.75V
DI-52	HECPA Stepper Voltage	13,33,53,73,93,113	62.5V
DI-53	HECPA Stepper Voltage	14,34,54,74,94,114	31.25V
DI-54	HECPA Stepper Voltage	15,35,55,75,95,115	12.5V
DI-55	HECPA Stepper Voltage	16,36,56,76,96,116	8.75V
DI-56	HECPA Stepper Voltage	17,37,57,77,97,117	6.25V
DI-57	HECPA Stepper Voltage	18,38,58,78,98,118	3.75V
DI-58	HECPA Stepper Voltage	19,39,59,79,99,119	2.5V
DI-59	HECPA Stepper Voltage	20,40,60,80,100,120	1.25V
DI-60	HECPA Stepper Voltage	0,121,122,123,124,125 126,127	0 V
Following measurements carried in ALSEP Word 56 even, SIDE Word 4 and in indicated SIDE Frames.			
DI-61	HE Data - MSD*	All	0 to 999 decimal
	*MSD - Most significant data.		
Following measurements carried in ALSEP Word 63 even, SIDE Word 5 and in indicated SIDE Frames.			
DI-62	HE Data - LSD**	All	0 to 999 decimal
	**LSD - Least significant data.		

Calibration counts are downlinked in the following SIDE frames:			
SIDE Frame	Calibration Rate Number	SIDE Word 4 5 (DI-61) (DI-62)	SIDE Word 9 10 (DF-5) (DF-6)
120	1	Science data	000 002 ±2
121	2	000 002 ±2	000 154 ±4
122	3	000 154 ±4	019 775 ±400
123	4	019 775 ±400	632 800 ±1400
124	1	632 800 ±1400	000 002 ±2
125	2	000 002 ±2	000 154 ±4
126	3	000 154 ±4	019 775 ±400
127	4	019 775 ±400	632 800 ±1400
000		632 800 ±1400	Science data

TABLE 6-XV.- SIDE/CCGE MEASUREMENTS - Continued

Symbol	Location/Name	SIDE Frame	Decimal Count
Following measurements carried in ALSEP Word 15 odd, SIDE Word 6, and in indicated SIDE Frames, bits 4 to 10 inclusive.*			
DI-63	Ground Plane Step	0,2,4,6,8,10,12,14,16 18,20,22,24,26,28,30 32,34,36,38,40,42,44,46,48 50,52,54,56,58,60,62,64, 66,68,70,72,74,76,78,80 82,84,86,88,90,92,94,96, 98,100,102,104,106,108,110 112,114,116,118	24 steps 0 - 11 16 - 27
DI-64	Command Register	1,5,13,17,21,29,33,37,45,49 53,61,65,69,77,81,85,93,97 101,109,113,117,125	0 to 15
DI-65	Mode Register	3,11,15,19,23,27,31,35,43,47 51,55,59,63,67,75,79,83,87 91,95,99,107,111,115,119	0 to 14
DI-66	Dust Cover and Seal	7,39,71,103	Dust Cover and Seal Blown -0 Seal Only -1 Dust Cover Only -2 Reset -3
DI-67	CCGE Electrometer Range	9,25,41,57,73,89,105	Range #1 - 0 Range #2 - 2 Range #3 - 3
DI-68	Cal Rate #1	120,124	0
DI-69	Cal Rate #2	121	1
DI-70	Cal Rate #3	122,126	2
DI-71	Cal Rate #4	123,127	3

\*SIDE Words 1 and 6 measurement content shown below

2 <sup>9</sup>	2 <sup>8</sup>	2 <sup>7</sup>	2 <sup>6</sup>	2 <sup>5</sup>	2 <sup>4</sup>	2 <sup>3</sup>	2 <sup>2</sup>	2 <sup>1</sup>	2 <sup>0</sup>
P	F <sub>1</sub>	F <sub>2</sub>	A <sub>1</sub>	A <sub>2</sub>	A <sub>3</sub>	A <sub>4</sub>	A <sub>5</sub>	A <sub>6</sub>	A <sub>7</sub>

P Parity

F Frame ID

A Data (LSB in A<sub>7</sub>)

DF-7           SIDE Parity           In SIDE Word 1 and 6,  
all frames

"1" odd number of ones  
in previous ALSEP frame.

DF-8           SIDE Frame ID           In SIDE Word 1 and 6,  
all frames.

"0" even number of ones  
in previous ALSEP frame.

00 even ALSEP frame.  
11 odd ALSEP frame.

TABLE 6-XV.- SIDE/CCGE MEASUREMENTS - Continued

Symbol	Location/Name	SIDE Frame		Nominal Value
		Normal Mode	Reset #9	Voltage
Following measurements carried in ALSEP Word 31 odd, SIDE Word 7 and in indicated SIDE Frames.				
DI-72	Velocity Filter Voltage	0	0,60	14.5 V
DI-73	Velocity Filter Voltage	1	1,61	13.2
DI-74	Velocity Filter Voltage	2	2,62	11.9
DI-75	Velocity Filter Voltage	3	3,63	10.7
DI-76	Velocity Filter Voltage	4	4,64	9.6
DI-77	Velocity Filter Voltage	5	5,65	8.5
DI-78	Velocity Filter Voltage	6	6,66	7.25
DI-79	Velocity Filter Voltage	7	7,67	6.65
DI-80	Velocity Filter Voltage	8	8,68	5.8
DI-81	Velocity Filter Voltage	9	9,69	5.0
DI-82	Velocity Filter Voltage	10		4.3
DI-83	Velocity Filter Voltage	11		3.65
DI-84	Velocity Filter Voltage	12		3.2
DI-85	Velocity Filter Voltage	13		2.57
DI-86	Velocity Filter Voltage	14		2.12
DI-87	Velocity Filter Voltage	15		1.75
DI-88	Velocity Filter Voltage	16		1.45
DI-89	Velocity Filter Voltage	17		1.20
DI-90	Velocity Filter Voltage	18		1.04
DI-91	Velocity Filter Voltage	19		0.94
DI-92	Velocity Filter Voltage	20	10,70	8.35
DI-93	Velocity Filter Voltage	21	11,71	7.6
DI-94	Velocity Filter Voltage	22	12,72	6.85
DI-95	Velocity Filter Voltage	23	13,73	6.2
DI-96	Velocity Filter Voltage	24	14,74	5.5
DI-97	Velocity Filter Voltage	25	15,75	4.93
DI-98	Velocity Filter Voltage	26	16,76	4.18
DI-99	Velocity Filter Voltage	27	17,77	3.83
DJ-0	Velocity Filter Voltage	28	18,78	3.34
DJ-1	Velocity Filter Voltage	29	19,79	2.8
DJ-2	Velocity Filter Voltage	30		2.48
DJ-3	Velocity Filter Voltage	31		2.10
DJ-4	Velocity Filter Voltage	32		1.85
DJ-5	Velocity Filter Voltage	33		1.48
DJ-6	Velocity Filter Voltage	34		1.23
DJ-7	Velocity Filter Voltage	35		1.01
DJ-8	Velocity Filter Voltage	36		0.84
DJ-9	Velocity Filter Voltage	37		0.695
DJ-10	Velocity Filter Voltage	38		0.60
DJ-11	Velocity Filter Voltage	39		0.54
DJ-12	Velocity Filter Voltage	40	20,80	4.82
DJ-13	Velocity Filter Voltage	41	21,81	4.39
DJ-14	Velocity Filter Voltage	42	22,82	3.97
DJ-15	Velocity Filter Voltage	43	23,83	3.57
DJ-16	Velocity Filter Voltage	44	24,84	3.19
DJ-17	Velocity Filter Voltage	45	25,85	2.85
DJ-18	Velocity Filter Voltage	46	26,86	2.44

TABLE 6-XV.- SIDE/CCGE MEASUREMENTS - Continued

Symbol	Location/Name	SIDE Frame		Nominal Value
		Normal Mode	Reset @	Voltage
DJ-19	Velocity Filter Voltage	47	27,87	2.21 V
DJ-20	Velocity Filter Voltage	48	28,88	1.93
DJ-21	Velocity Filter Voltage	49	29,89	1.67
DJ-22	Velocity Filter Voltage	50		1.43
DJ-23	Velocity Filter Voltage	51		1.22
DJ-24	Velocity Filter Voltage	52		1.07
DJ-25	Velocity Filter Voltage	53		0.85
DJ-26	Velocity Filter Voltage	54		0.71
DJ-27	Velocity Filter Voltage	55		0.59
DJ-28	Velocity Filter Voltage	56		0.484
DJ-29	Velocity Filter Voltage	57		0.402
DJ-30	Velocity Filter Voltage	58		0.345
DJ-31	Velocity Filter Voltage	59		0.312
DJ-32	Velocity Filter Voltage	60	30,90	2.78
DJ-33	Velocity Filter Voltage	61	31,91	2.53
DJ-34	Velocity Filter Voltage	62	32,92	2.29
DJ-35	Velocity Filter Voltage	63	33,93	2.06
DJ-36	Velocity Filter Voltage	64	34,94	1.85
DJ-37	Velocity Filter Voltage	65	35,95	1.65
DJ-38	Velocity Filter Voltage	66	36,96	1.40
DJ-39	Velocity Filter Voltage	67	37,97	1.78
DJ-40	Velocity Filter Voltage	68	38,98	1.12
DJ-41	Velocity Filter Voltage	69	39,99	0.965
DJ-42	Velocity Filter Voltage	70		0.825
DJ-43	Velocity Filter Voltage	71		0.70
DJ-44	Velocity Filter Voltage	72		0.615
DJ-45	Velocity Filter Voltage	73		0.494
DJ-46	Velocity Filter Voltage	74		0.409
DJ-47	Velocity Filter Voltage	75		0.337
DJ-48	Velocity Filter Voltage	76		0.278
DJ-49	Velocity Filter Voltage	77		0.232
DJ-50	Velocity Filter Voltage	78		0.20
DJ-51	Velocity Filter Voltage	79		0.180
DJ-52	Velocity Filter Voltage	80	40,100	1.61
DJ-53	Velocity Filter Voltage	81	41,101	1.46
DJ-54	Velocity Filter Voltage	82	42,102	1.32
DJ-55	Velocity Filter Voltage	83	43,103	1.19
DJ-56	Velocity Filter Voltage	84	44,104	1.07
DJ-57	Velocity Filter Voltage	85	45,105	0.95
DJ-58	Velocity Filter Voltage	86	46,106	0.81
DJ-59	Velocity Filter Voltage	87	47,107	0.74
DJ-60	Velocity Filter Voltage	88	48,108	0.65
DJ-61	Velocity Filter Voltage	89	49,109	0.55
DJ-62	Velocity Filter Voltage	90		0.477
DJ-63	Velocity Filter Voltage	91		0.405
DJ-64	Velocity Filter Voltage	92		0.355
DJ-65	Velocity Filter Voltage	93		0.285
DJ-66	Velocity Filter Voltage	94		0.236



TABLE 6-XV.- SIDE/CCGE MEASUREMENTS - Continued

Symbol	Location/Name	SIDE Frame		Nominal Value
		Normal Mode	Reset @9	Voltage
DJ-67	Velocity Filter Voltage	95		0.195
DJ-68	Velocity Filter Voltage	96		0.160
DJ-69	Velocity Filter Voltage	97		0.134
DJ-70	Velocity Filter Voltage	98		0.115
DJ-71	Velocity Filter Voltage	99		0.104
DJ-72	Velocity Filter Voltage	100	50,110	0.93
DJ-73	Velocity Filter Voltage	101	51,111	0.85
DJ-74	Velocity Filter Voltage	102	52,112	0.765
DJ-75	Velocity Filter Voltage	103	53,113	0.685
DJ-76	Velocity Filter Voltage	104	54,114	0.615
DJ-77	Velocity Filter Voltage	105	55,115	0.55
DJ-78	Velocity Filter Voltage	106	56,116	0.465
DJ-79	Velocity Filter Voltage	107	57,117	0.425
DJ-80	Velocity Filter Voltage	108	58,118	0.372
DJ-81	Velocity Filter Voltage	109	59,119	0.321
DJ-82	Velocity Filter Voltage	110		0.275
DJ-83	Velocity Filter Voltage	111		0.234
DJ-84	Velocity Filter Voltage	112		0.205
DJ-85	Velocity Filter Voltage	113		0.165
DJ-86	Velocity Filter Voltage	114		0.136
DJ-87	Velocity Filter Voltage	115		0.112
DJ-88	Velocity Filter Voltage	116		0.093
DJ-89	Velocity Filter Voltage	117		0.077
DJ-90	Velocity Filter Voltage	118		0.067
DJ-91	Velocity Filter Voltage	119		0.060
DJ-92	Velocity Filter Voltage	120	120	14.5
DJ-93	Velocity Filter Voltage	121	121	13.2
DJ-94	Velocity Filter Voltage	122	122	11.9
DJ-95	Velocity Filter Voltage	123	123	10.7
DJ-96	Velocity Filter Voltage	124	124	9.6
DJ-97	Velocity Filter Voltage	125,126,127	125,126,127	>16.1
Following measurements carried in ALSEP Word 47 odd, SIDE Word 8 and in indicated SIDE Frames.				
		Normal Mode	Reset Vel Filter @9	Voltage
DJ-98	LECPA Stepper Voltage	0-19	0-9,60-69	12.15 V
DJ-99	LECPA Stepper Voltage	20-39	10-19,70-79	4.050
DF-0	LECPA Stepper Voltage	40-59	20-29,80-89	1.35
DF-1	LECPA Stepper Voltage	60-79	30-39,90-99	0.450
DF-2	LECPA Stepper Voltage	80-99	40-49,100-109	0.150
DF-3	LECPA Stepper Voltage	100-119	50-59,110-119	0.050
DF-4	LECPA Stepper Voltage	120-127	120-127	0 V
Following measurements carried in ALSEP Word 56 odd, SIDE Word 9 and in indicated SIDE Frames.				
DF-5	LE Data - MSD	All		0 to 999 decimal
Following measurements carried in ALSEP Word 63 odd, SIDE Word 10 and in indicated SIDE Frames.				
DF-6	LE Data - LSD	All		0 to 999 decimal
Two SIDE measurements are included in ALSEP Housekeeping Word 33				
		Channel		
AI-1	LE Count Rate	70		0 to $1.4 \times 10^6$ counts/sec
AI-2	HE Count Rate	85		0 to $1.4 \times 10^6$ counts/sec

Heat Flow Word	Bit Position										ALSEP Frames
	1	2	3	4	5	6	7	8	9	10	
0	$R_2$	$R_1$	0	$P_4$	$P_3$	$P_2$	$P_1$	$2^{12}$	$2^{11}$	$2^{10}$	0
	$2^9$	$2^8$	$2^7$	$2^6$	$2^5$	$2^4$	$2^3$	$2^2$	$2^1$	$2^0$	1
1	$R_2$	$R_1$	$M_1$	$M_2$	$M_3$	0	0	$2^{12}$	$2^{11}$	$2^{10}$	2
	$2^9$	$2^8$	$2^7$	$2^6$	$2^5$	$2^4$	$2^3$	$2^2$	$2^1$	$2^0$	3
2	$R_2$	$R_1$	$H_4$	$H_3$	$H_2$	$H_1$	0	$2^{12}$	$2^{11}$	$2^{10}$	4
	$2^9$	$2^8$	$2^7$	$2^6$	$2^5$	$2^4$	$2^3$	$2^2$	$2^1$	$2^0$	5
3	$R_2$	$R_1$	0	0	0	0	0	$2^{12}$	$2^{11}$	$2^{10}$	6
	$2^9$	$2^8$	$2^7$	$2^6$	$2^5$	$2^4$	$2^3$	$2^2$	$2^1$	$2^0$	7

## Notes:

1. It takes two ALSEP main frames to downlink one heat flow word. It takes four heat flow words to obtain one measurement except in Thermocouple Group Probe 1 and 2. In Thermocouple Group Probe 1 and 2 each heat flow word contains a single measurement.
2. Measurement DH-90:  $M_1$ ,  $M_2$ , and  $M_3$  identifies mode.
3. Measurement DH-91:  
 $P_4$ ,  $P_3$ ,  $P_2$ , and  $P_1$  are measurement identification in gradient mode and low conductivity mode.
4. Measurement DH-92:  
 $R_2$  and  $R_1$  are the binary equivalent of heat flow word and identify the analog parameters (13-bits) that are used in the calculation to derive the engineering units for a measurement number.
5. Measurement DH-93:  
 $H_4$ ,  $H_3$ ,  $H_2$ , and  $H_1$  identify the conductivity heater status. In the high conductivity mode it identifies the measurement numbers also.
6. Measurement DH-94:  
Filler bits (shown as zeros in above chart).

Figure 6-6. - HFE word format.

\*

TABLE 6-XVI.- HFE MEASUREMENTS, MODE 1 AND 2 GRADIENT AND LOW CONDUCTIVITY

SYMBOL	LOCATION/MEASUREMENT	FRAME	RANGE
DH-1	$\Delta T_{11}$ H Temp Grad High Sens	0-7	$\pm 2^{\circ}\text{C}$
DH-2	$\Delta T_{12}$ H Temp Grad High Sens	8-15	$\pm 2^{\circ}\text{C}$
DH-3	$\Delta T_{21}$ H Temp Grad High Sens	90-97	$\pm 2^{\circ}\text{C}$
DH-4	$\Delta T_{22}$ H Temp Grad High Sens	98-105	$\pm 2^{\circ}\text{C}$
DH-5	$\Delta T_{11}$ L Temp Grad Low Sens	180-187	$\pm 20^{\circ}\text{C}$
DH-6	$\Delta T_{12}$ L Temp Grad Low Sens	188-195	$\pm 20^{\circ}\text{C}$
DH-7	$\Delta T_{21}$ L Temp Grad Low Sens	270-277	$\pm 20^{\circ}\text{C}$
DH-8	$\Delta T_{22}$ L Temp Grad Low Sens	278-285	$\pm 20^{\circ}\text{C}$
DH-9	T <sub>11</sub> Probe, Ambient Temp	360-367	200 to 250°K
DH-10	T <sub>12</sub> Probe, Ambient Temp	368-375	200 to 250°K
DH-11	T <sub>21</sub> Probe, Ambient Temp	450-457	200 to 250°K
DH-12	T <sub>22</sub> Probe, Ambient Temp	458-465	200 to 250°K
DH-13	Ref T <sub>1</sub> , Temp Ref Junction	540-547	-20 to +60°C
* DH-14, 24, 34, 44	TC <sub>1</sub> Group Probe Cable Temp	548-555	90 to 350°K
DH-15	Ref T <sub>2</sub> , Temp Ref Junction	630-637	-20 to +60°C
* DH-16, 26, 36, 46	TC <sub>2</sub> Group Probe Cable Temp	638-645	90 to 350°K

\*See Table 8-1 for these measurements.

TABLE 6-XVII.- HFE MEASUREMENTS, MODE 3, HIGH CONDUCTIVITY

SYMBOL	LOCATION/MEASUREMENT	FRAME	RANGE	H-BITS	PROBE	BRIDGE	HEATER STATUS
DH-50	Differential Temp	0-7		0000	1	1	Off
DH-51	Ambient Temp	8-15		0000	1	1	Off
DH-52	Differential Temp	0-7		0001	1	1	H <sub>12</sub> On
DH-53	Ambient Temp	8-15		0001	1	1	H <sub>12</sub> On
DH-60	Differential Temp	0-7		0010	1	2	Off
DH-61	Ambient Temp	8-15		0010	1	2	Off
DH-62	Differential Temp	0-7		0011	1	2	H <sub>14</sub> On
DH-63	Ambient Temp	8-15		0011	1	2	H <sub>14</sub> On
DH-56	Differential Temp	0-7		0100	1	1	Off
DH-57	Ambient Temp	8-15		0100	1	1	Off
DH-58	Differential Temp	0-7		0101	1	1	H <sub>11</sub> On
DH-59	Ambient Temp	8-15		0101	1	1	H <sub>11</sub> On
DH-66	Differential Temp	0-7		0110	1	2	Off
DH-67	Ambient Temp	8-15		0110	1	2	Off
DH-68	Differential Temp	0-7		0111	1	2	H <sub>13</sub> On
DH-69	Ambient Temp	8-15		0111	1	2	H <sub>13</sub> On
DH-70	Differential Temp	0-7		1000	2	1	Off
DH-71	Ambient Temp	8-15		1000	2	1	Off
DH-72	Differential Temp	0-7		1001	2	1	H <sub>22</sub> On
DH-73	Ambient Temp	8-15		1001	2	1	H <sub>22</sub> On
DH-80	Differential Temp	0-7		1010	2	2	Off
DH-81	Ambient Temp	8-15		1010	2	2	Off
DH-82	Differential Temp	0-7		1011	2	2	H <sub>24</sub> On
DH-83	Ambient Temp	8-15		1011	2	2	H <sub>24</sub> On
DH-76	Differential Temp	0-7		1100	2	1	Off
DH-77	Ambient Temp	8-15		1100	2	1	Off
DH-78	Differential Temp	0-7		1101	2	1	H <sub>21</sub> On
DH-79	Ambient Temp	8-15		1101	2	1	H <sub>21</sub> On
DH-86	Differential Temp	0-7		1110	2	2	Off
DH-87	Ambient Temp	8-15		1110	2	2	Off
DH-88	Differential Temp	0-7		1111	2	2	H <sub>23</sub> On
DH-89	Ambient Temp	8-15		1111	2	2	H <sub>23</sub> On

TABLE 6-XVIII.- HFE MEASUREMENTS, ANALOG

SYMBOL	LOCATION/MEASUREMENT	CHANNEL	RANGE	DECIMAL PCM
AH-1	Supply Voltage #1	29	0 to +5 Volts	
AH-2	Supply Voltage #2	45	0 to -5 Volts	
AH-3	Supply Voltage #3	55	0 to +15 Volts	
AH-4	Supply Voltage #4	74	0 to -15 Volts	
AH-5	Not Assigned			
AH-6	Low Cond Heater Power Status	57	2 to 2.5 Volts On otherwise Off	102-128 Htr On 3-101 Htr Off
AH-7	High Cond Heater Power Status	75	2 to 2.5 Volts On otherwise Off	102-128 Htr On 3-101 Htr Off

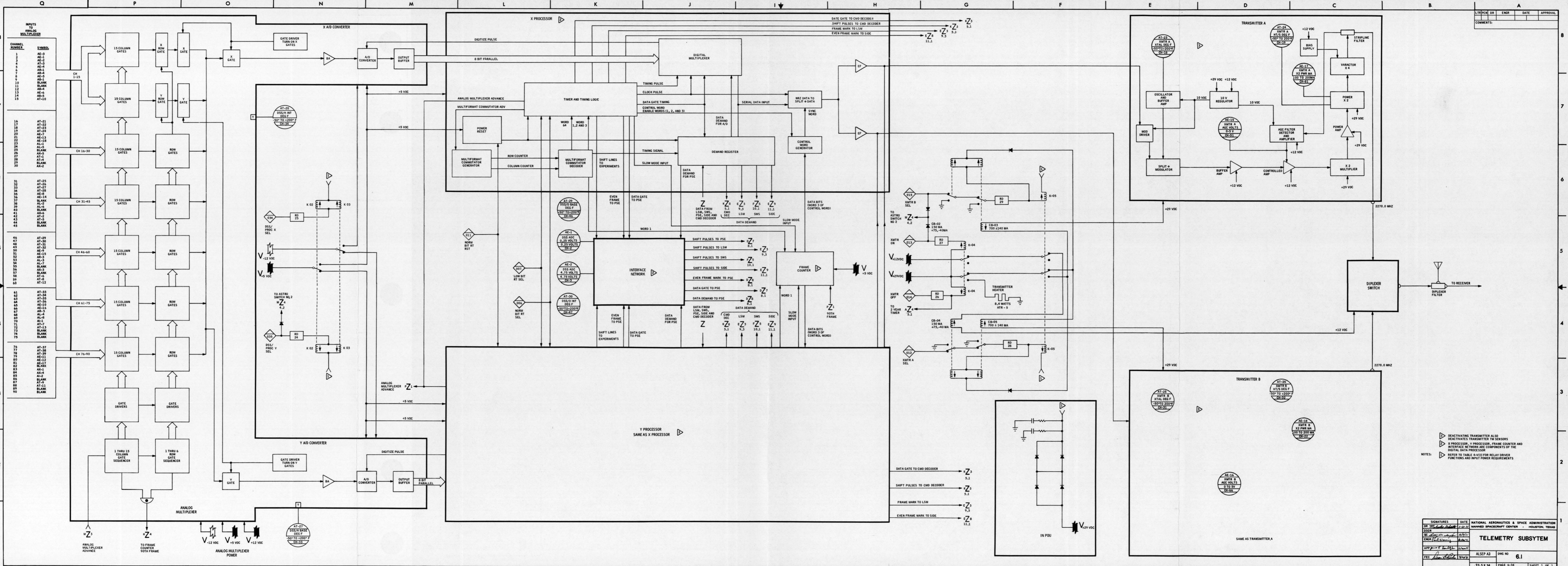

NOTES:  
 DEACTIVATING TRANSMITTER ALSO DEACTIVATES TRANSMITTER TM SENSORS  
 X PROCESSOR, Y PROCESSOR, FRAME COUNTER AND INTERFACE NETWORK ARE COMPONENTS OF THE DIGITAL DATA PROCESSOR  
 REFER TO TABLE 4-VIII FOR RELAY DRIVER FUNCTIONS AND INPUT POWER REQUIREMENTS

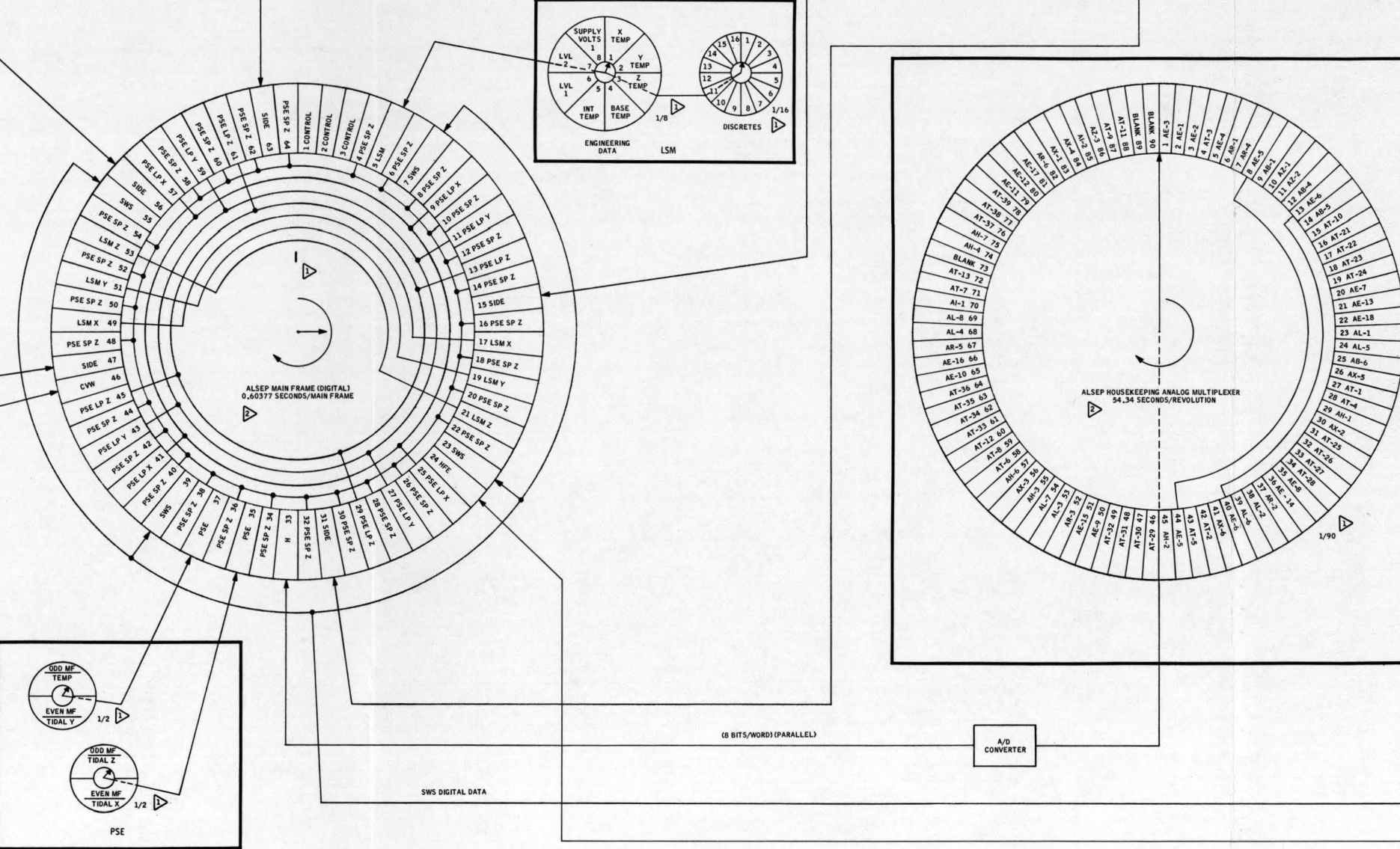
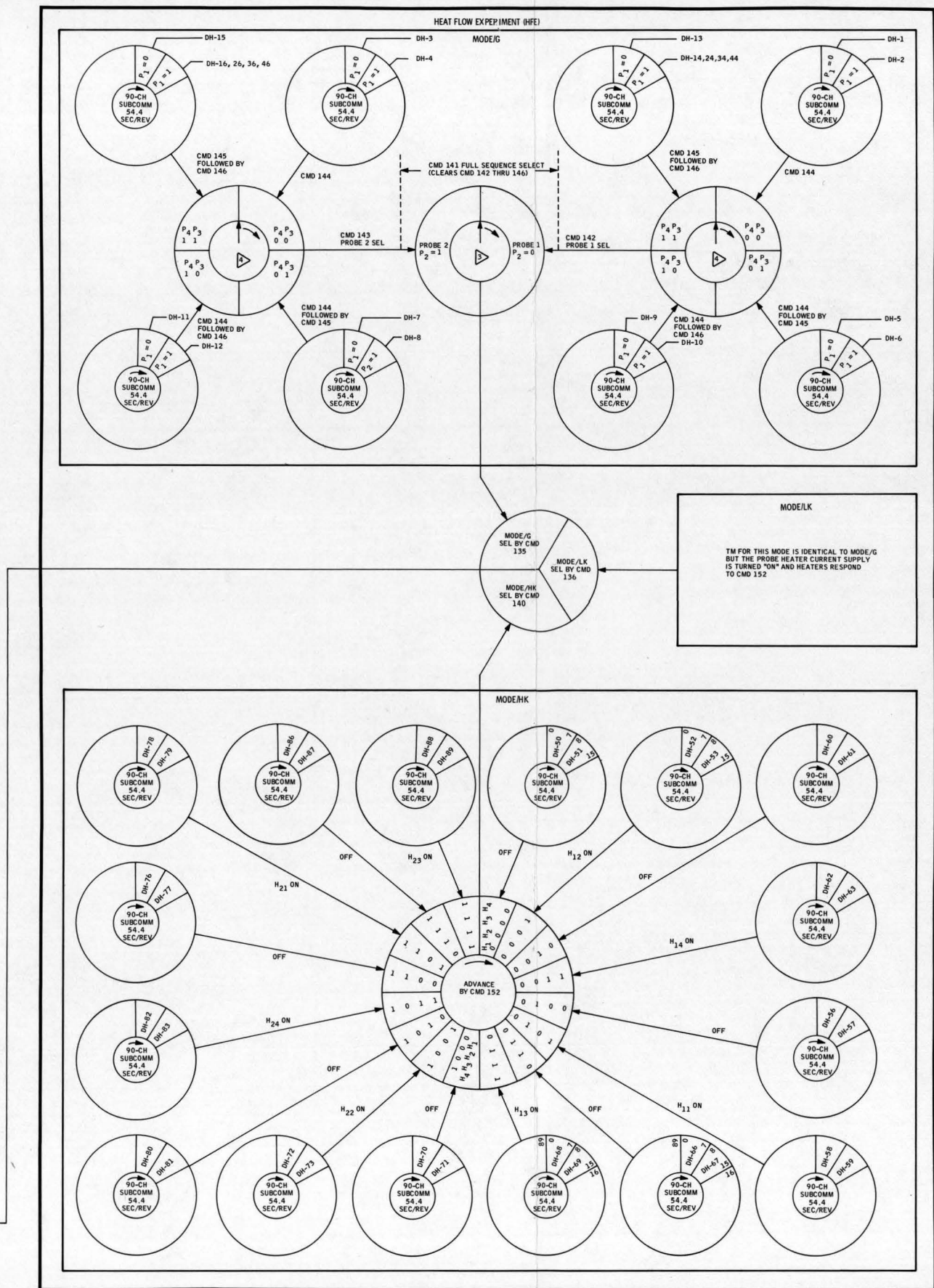
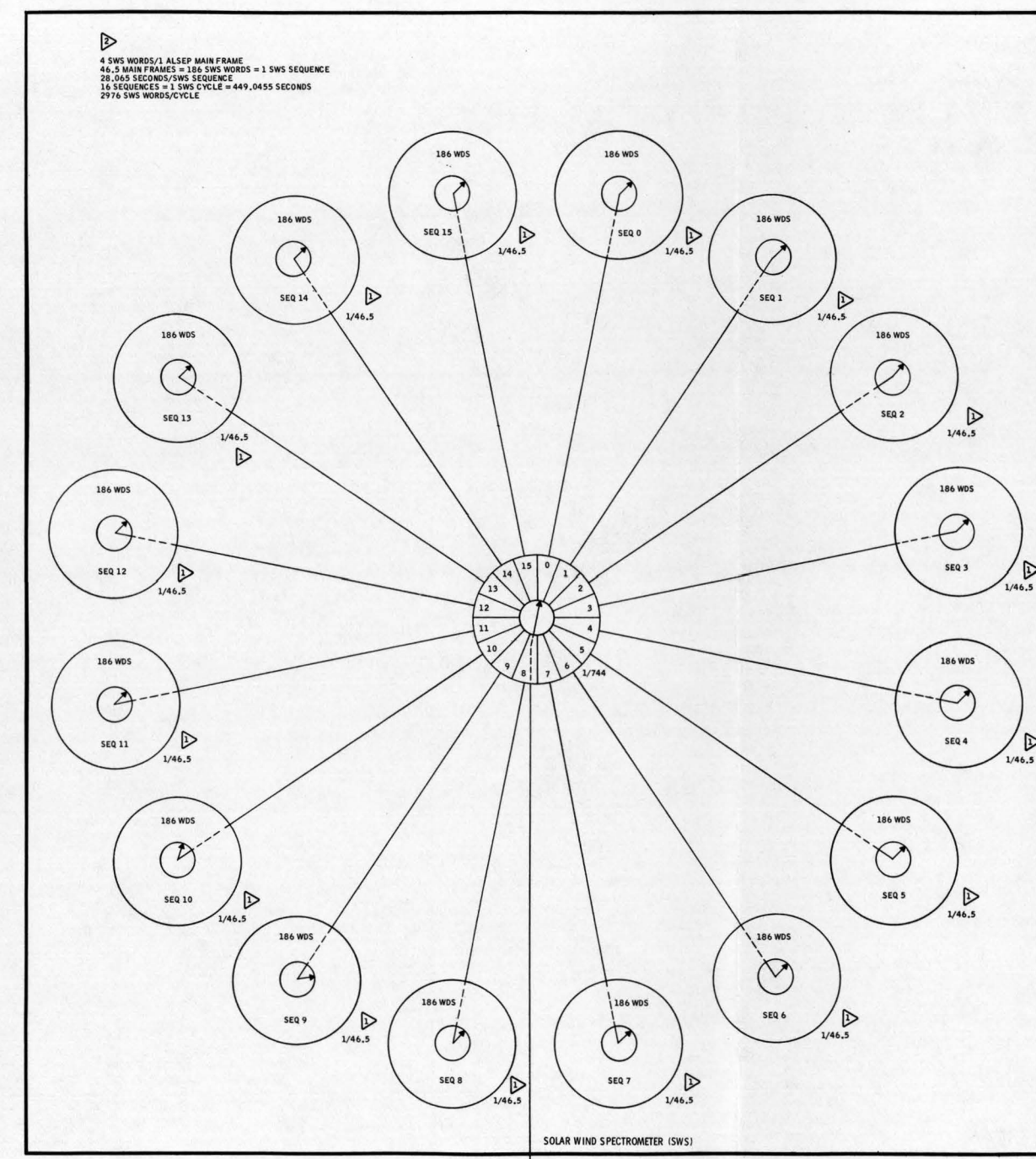
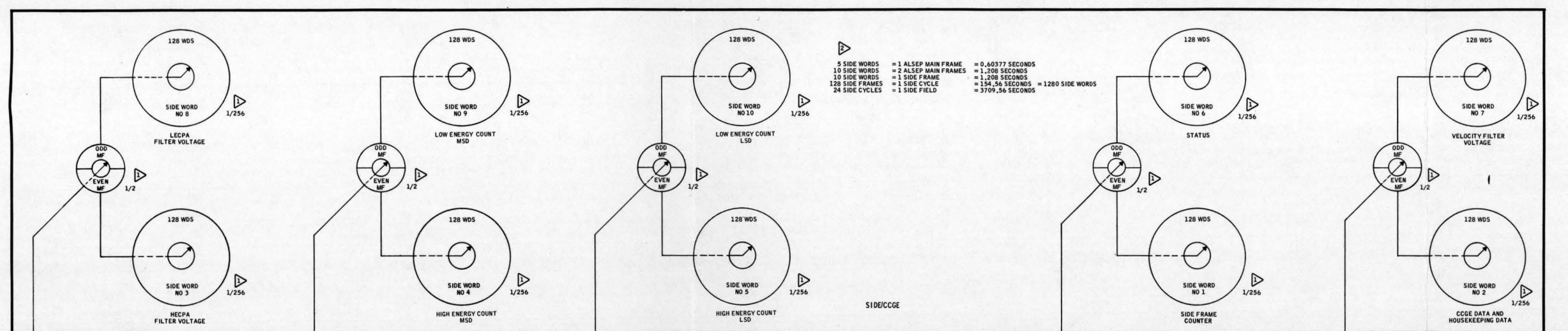

CMD	CMD	SUBCOMM	MEASUREMENT	SUBCOMM
141	144	0	0	DH-1 THRU 4
142	144	0	0	DH-1 AND 2
143	144	0	0	DH-3 AND 4
141	144	1	0	DH-5 THRU 8
142	144	1	0	DH-5 AND 6
143	144	1	0	DH-7 AND 8
141	144	1	1	DH-9 THRU 12
142	144	1	0	DH-9 AND 10
143	144	1	0	DH-11 AND 12
141	145	1	1	DH-13 AND 15, 16-44, 16-46
142	145	1	1	DH-13 AND 14, 24, 34, 44
143	145	1	1	DH-15 AND 16, 26, 36, 46

NOTES:  
 1. NUMBERS ARE RELATIONS TO ALSEP MAIN FRAME RATE.  
 2. EXAMPLE: WHEN THE ALSEP MAIN FRAME COMPLETES ONE REVOLUTION ALSEP HOUSEKEEPING ANALOG MIX TURNS 1/90 OF A REVOLUTION.  
 3. WHEN CMD 141 IS EXECUTED, THE SUBCOMM RATE IS 54.34 SEC/REV. BOTH PROBES ARE SAMPLED.  
 4. WHEN CMD 142 IS EXECUTED, THE SUBCOMM RATE IS LOCKED IN THE "1" STATE. ONLY PROBE 1 IS BEING SAMPLED.  
 5. WHEN CMD 143 IS EXECUTED, THE SUBCOMM RATE IS LOCKED IN THE "1" STATE. ONLY PROBE 2 IS BEING SAMPLED. THE SUBCOMM RATE IN EITHER OF THESE TWO STATES IS 217.556 SEC/REV.  
 6. TIMES ARE FOR NORMAL BIT RATE (1066 SPS)

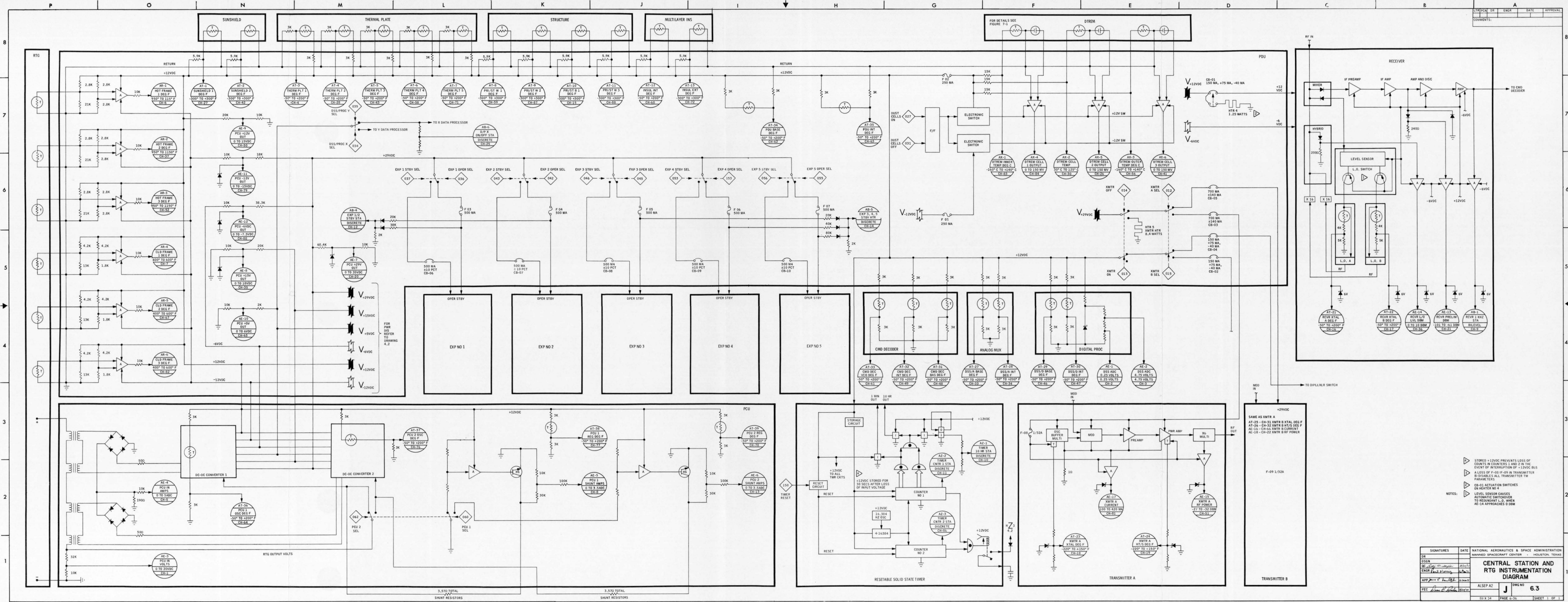

DATE	ENGR	DR	TR	APPROVAL

NOTES:

- STORAGE - 12VDC PREVENTS LOSS OF COUNTS IN COUNTERS 1 AND 2 IN THE EVENT OF INTERRUPTION OF +12VDC BUS
- A LOSS OF F-09 IN TRANSMITTER B DISABLES ALL TRANSMITTER TM PARAMETERS
- LEVEL SENSOR SWITCHES AUTOMATIC SWITCHOVER TO REDUNDANT L.O. WHEN AE-14 APPROACHES 0 DBM

SIGNATURES		DATE	NATIONAL AERONAUTICS & SPACE ADMINISTRATION MANNED SPACECRAFT CENTER - HOUSTON, TEXAS
DR			
DSGN			
ENGR			
APP			
FEC			

**CENTRAL STATION AND RTG INSTRUMENTATION DIAGRAM**

ALSEP A2  
DWG NO 6.3  
SHEET 1 OF 1

SECTION 7

DTREM SUBSYSTEM (M-515)

7.1 SYSTEM OBJECTIVES

The dust, thermal, and radiation engineering measurements package (DTREM) is used for the following:

- A. To measure radiation damage to three solar cells by monitoring the degradation in their voltage output
- B. To measure dust accumulation caused by the LM ascent
- C. To measure reflected infrared energy to obtain the lunar surface "brightness" temperature

7.2 EQUIPMENT DESCRIPTION

The DTREM sensor package is mounted on the top surface of the central station sunshield with the outer temperature sensor (AX-3) nominally facing west. Three solar cells are mounted on a cell mounting plate facing vertical (refer to Figure 7-1). Number one cell has no filter; the second cell, intentionally damaged by radiation (irradiated) preflight, has a 6-mil blue filter; and the third cell has a 6-mil blue filter installed.

The temperature (AX-2) of the cells is monitored by a sensor mounted on the underside of the cell mounting plate. An inner temperature sensor (AX-1) and an outer temperature sensor (AX-3) are mounted on a vertical wall of the sensor package and are used to determine the lunar surface temperature.

The solar cells and temperature sensors are connected to a printed circuit board in the PDU through an H-film cable. The circuit board contains three amplifiers for signal conditioning the solar cell outputs, logic circuits necessary to switch



power (by ground commands) to the cell amplifiers, and the wiring necessary to route operating voltage to the temperature sensors. Note that the temperature sensor operating voltage is not switched (refer to Drawing 7.1).

### 7.3 EXPERIMENT OPERATION

The solar cell voltages should vary between 0 and 75 millivolts during the lunar day with the variation caused primarily by sun angle and cell temperature. The cell outputs will be corrected for sun angle and temperature and the remaining variables will be due to the relatively long-term radiation damage and the somewhat shorter-term degradation from dust accumulation caused by the LM ascent.

The cell temperature should range between approximately 30° and 125° C during the lunar day. During lunar night, the temperature readings (AX-1, AX-2, and AX-3) and the cell outputs (AX-4, AX-5, and AX-6) will be off scale.

The particle energy thresholds for cell damage with a 6-mil blue filter are 4.3 Mev and 175 kev for positively charged and negatively charged particles respectively. For the unfiltered cell (Cell 1) the thresholds are 60 kev and 170 kev for positive and negative particles. It is expected that the major cause of cell damage will be from solar flares, and cell degradation must be correlated with flare activity.

Since Cell 2 has been intentionally degraded a known amount by a known particle energy level, it will serve as a quasi-standard cell by which the degradation of Cells 1 and 3 will be measured.

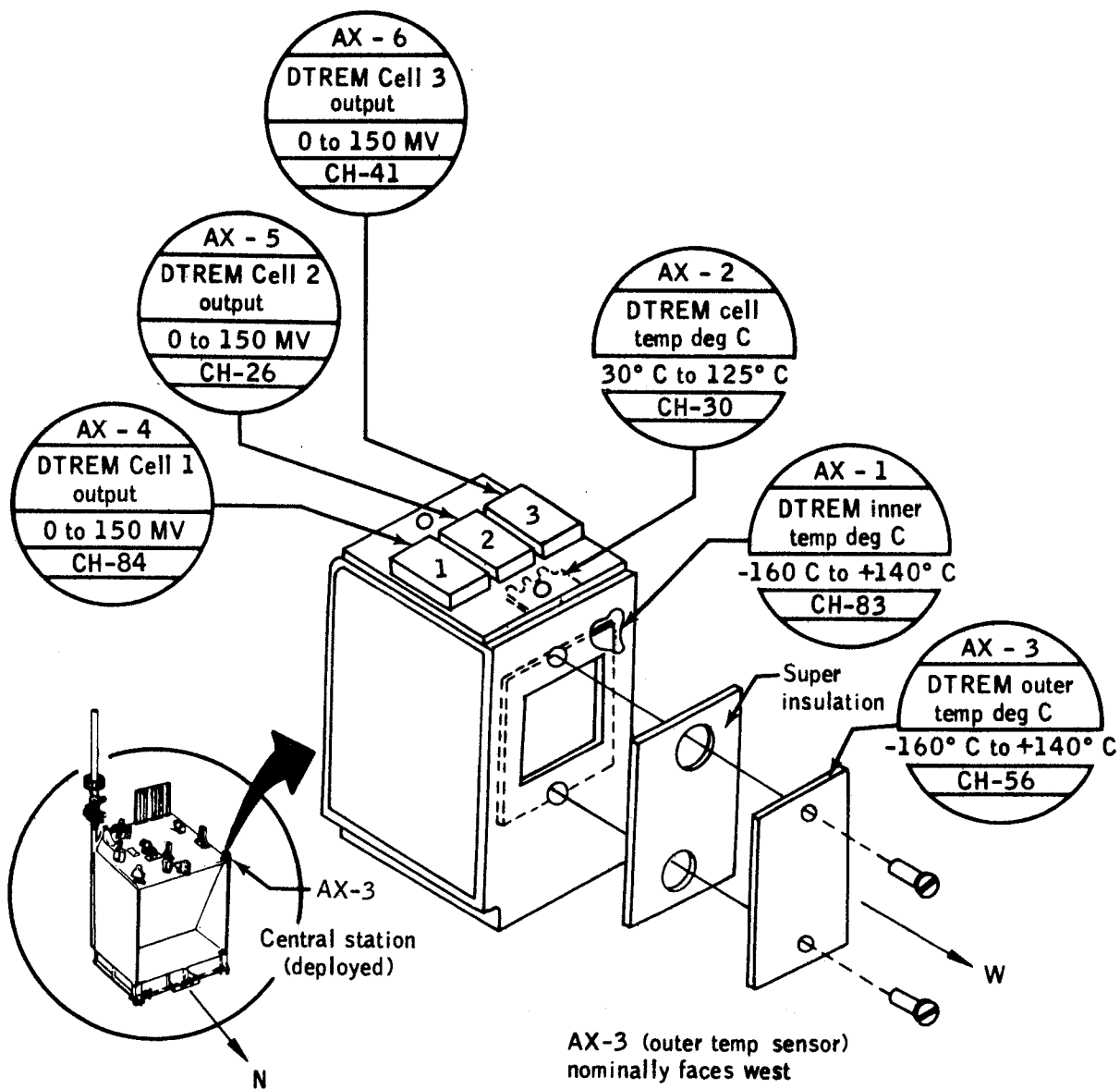

- Cell 1 No filter
- Cell 2 Irradiated cell, 6 mil blue filter
- Cell 3 6 Mil blue filter

Figure 7-1. - DTREM.

A					
LTR	PCN	DR	ENG	DATE	APPROVAL
COMMENTS:					

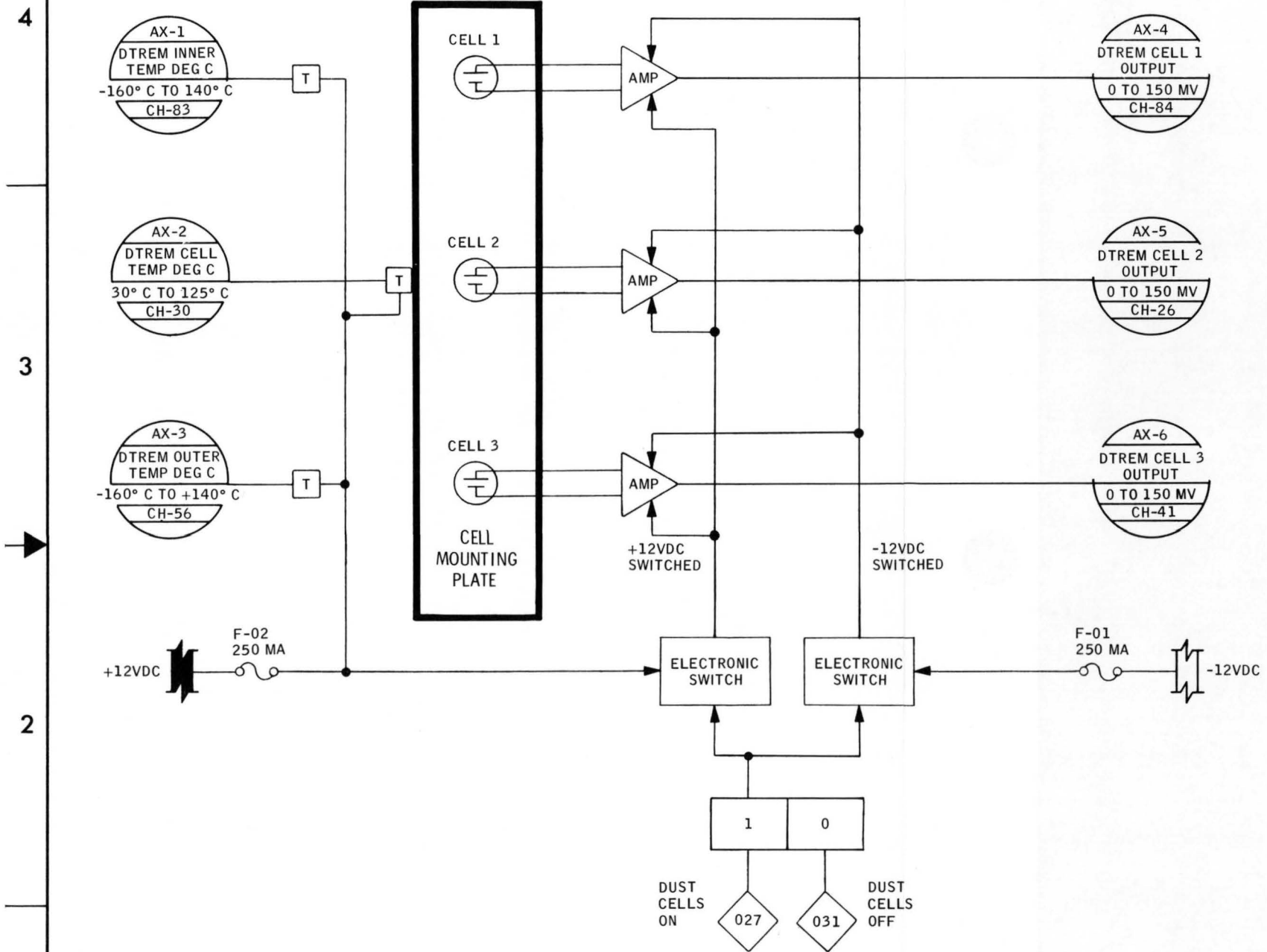

NOTE: 1.

VOLTAGE BUS	POWER	CIRCUIT PROTECTION
-12	100 MW	F-01 250 MA
+12	153 MW	F-02 250 MA

A BLOWN FUSE F-01 WILL PERMANENTLY DISABLE THE DTREM, RESULTING IN LOSS OF PHOTOELECTRIC CELL VOLTAGE TM PARAMETERS AX-4, AX-5, AND AX-6

A BLOWN FUSE F-02 WILL PERMANENTLY DISABLE THE DTREM, RESULTING IN LOSS OF PHOTOELECTRIC CELL VOLTAGE TM PARAMETERS AX-4, AX-5, AND AX-6 AND TEMPERATURE TM PARAMETERS AX-1, AX-2, AND AX-3

SIGNATURES		DATE	NATIONAL AERONAUTICS & SPACE ADMINISTRATION MANNED SPACECRAFT CENTER • HOUSTON, TEXAS		
DR	<i>Fanto</i>	1/20/71	<h1>DTREM SCHEMATIC</h1>		
DSGN					
QC	<i>John M. Taylor</i>	2/17/71			
ENGR	<i>Paul Nervis</i>	11/10/71			
APP	<i>James E. Saulted</i>	11/10/71			
FEC	<i>Dean B. Fisher</i>	3/20/71	ALSEP A2	SIZE <b>C</b>	DWG NO <b>7.1</b>
			22 X 17	PAGE 7-4	SHEET 1 OF 1

\*

SECTION 8

PASSIVE SEISMIC EXPERIMENT (S-031)

8.1 SYSTEM DESCRIPTION

The passive seismic experiment (PSE) provides data on lunar seismic activity and the properties of the lunar interior. The PSE does this by monitoring the long-period, low-frequency and the short-period, high-frequency energy associated with lunar quakes as well as measuring the direction and the distance to the seismic epicenters.

Physically, the PSE consists of two parts, both included in one package. The long-period instrument, which contains three seismometers (one vertical and two horizontal, placed orthogonally to each other), measures long-period, low-frequency seismic energy with a period of 250 to 0.3 seconds. This instrument measures the distance and direction to a seismic quake, as well as the long-term tidal deformations of the moon. The short-period instrument functions as a velocity transducer which measures short-period (5 to 0.04 seconds), high-frequency (up to 25 cycles per second) seismic energy with very high sensitivity. The instrument consists of a moving-magnet mass built so that a transducer can measure the velocity of the magnet. The displacements and the velocity of these instruments are measured, amplified, and filtered in a series of electronic circuits which produce an output signal to the central station data processor.

When the PSE is deployed by the crew, it must be leveled to within  $\pm 5$  degrees. Within the instrument case, the seismic elements are mounted on gimbals having leveling motors which can level from an initial tilt as great as 5 degrees. By using a combination of "coarse-level" sensors and the horizontal

\*  
seismometers, the PSE can be leveled on command to within 3 arc-seconds.

The PSE will normally be leveled using the auto leveling mode (refer to Table 8-I for the preset conditions) with the forced mode as a backup method. The coarse sensors (utilized only in the X and Y axes) will be commanded in for the initial leveling sequence. The coarse sensors are effective in the auto mode only and provide the X- or Y-axis leveling motor drive signals when there exists an off level condition greater than 8 arc-minutes. At this point the axes' tidal outputs provide the leveling motor drive signals to control leveling to the final level condition.

TABLE 8-I.- PSE PRESET CONDITIONS

["Preset" is defined as the logic condition initialized by activation of the experiment]

Command	Function	Presets to	Lunar deployment condition
037	EXP 1 STBY SEL		Exp in stby
063	PSE/XY GAIN CH	-30 dB	
064	PSE/Z GAIN CH	-30 dB	
065	PSE/SP CAL CH	Off	
066	PSE/LP CAL CH	Off	
067	PSE/SP GAIN CH	-30 dB	
070	LVL MTRX ON/OFF	Off	
071	LVL MTRY ON/OFF	Off	
072	LVL MTRZ ON/OFF	Off	
073	UNCAGE ARM/FIRE	Caged	
074	LVL DIR POS/NEG	Pos	
075	LVL SPEED HI/LO	Low	
076	PSE T CTL CH	Auto on	
101	PSE FILT IN/OUT	Out	
102	LVL SNSR IN/OUT	Out	
103	PSE LVL MDE A/F	Auto	

TABLE 8-II.- PSE LEVELING RATES

Condition	X or Y	Z
Power mode		
High speed	152 to 305 $\mu$ rad/sec	20 to 40 mgal/sec
Low speed	5.1 to 17.7 $\mu$ rad/sec	0.67 to 2.34 mgal/sec
Automatic mode		
Coarse sensor in (off level >8 arc-min)	152 to 305 $\mu$ rad/sec	No coarse sensor on Z-axis. Use forced mode.
Coarse sensor out (tidal output saturated)	3.8 to 7.6 $\mu$ rad/sec	0.5 to 1.0 mgal/sec
Coarse sensor out (tidal data unsaturated)	0 to 3.8 $\mu$ rad/sec	0 to 1.0 mgal/sec

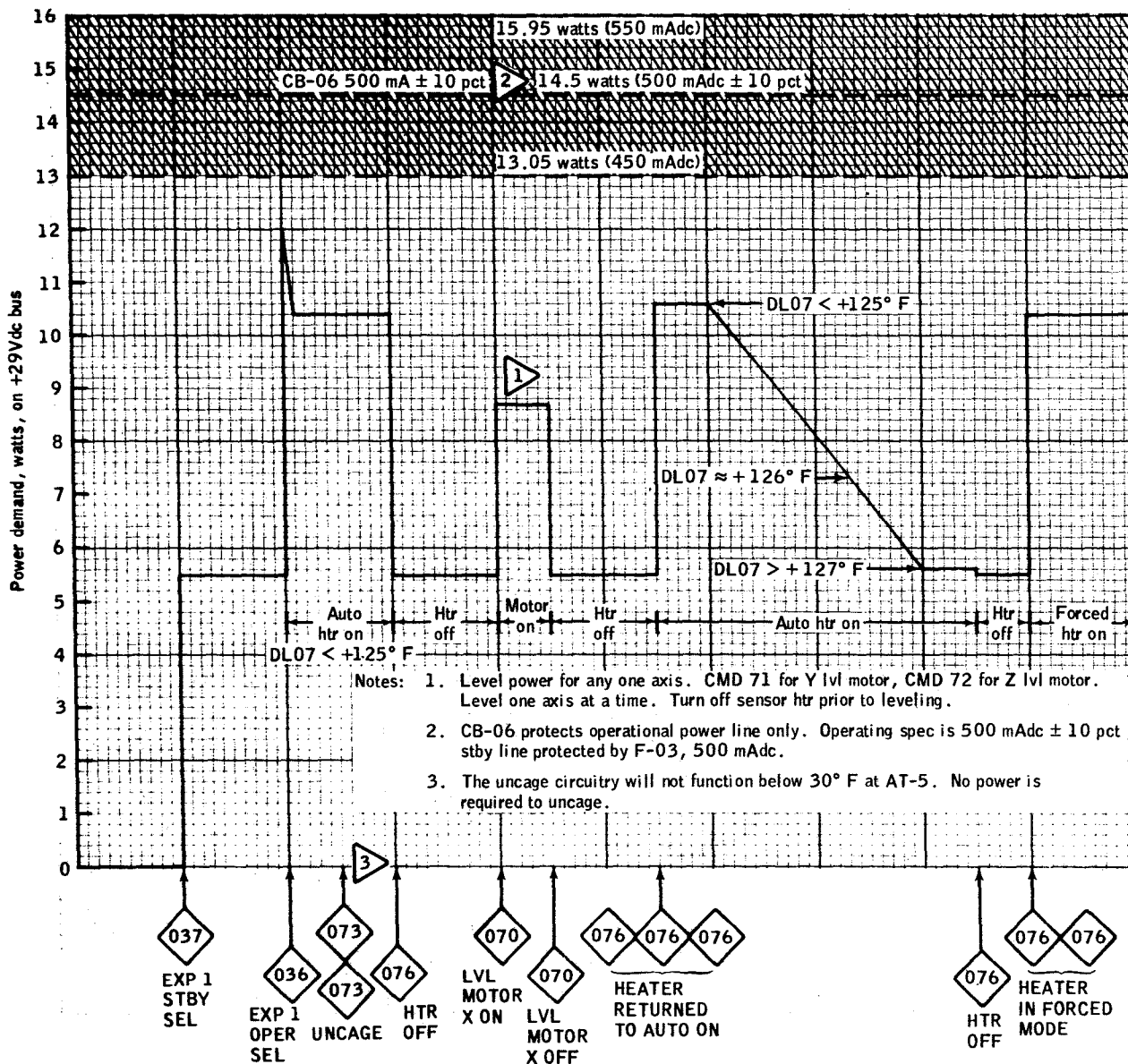
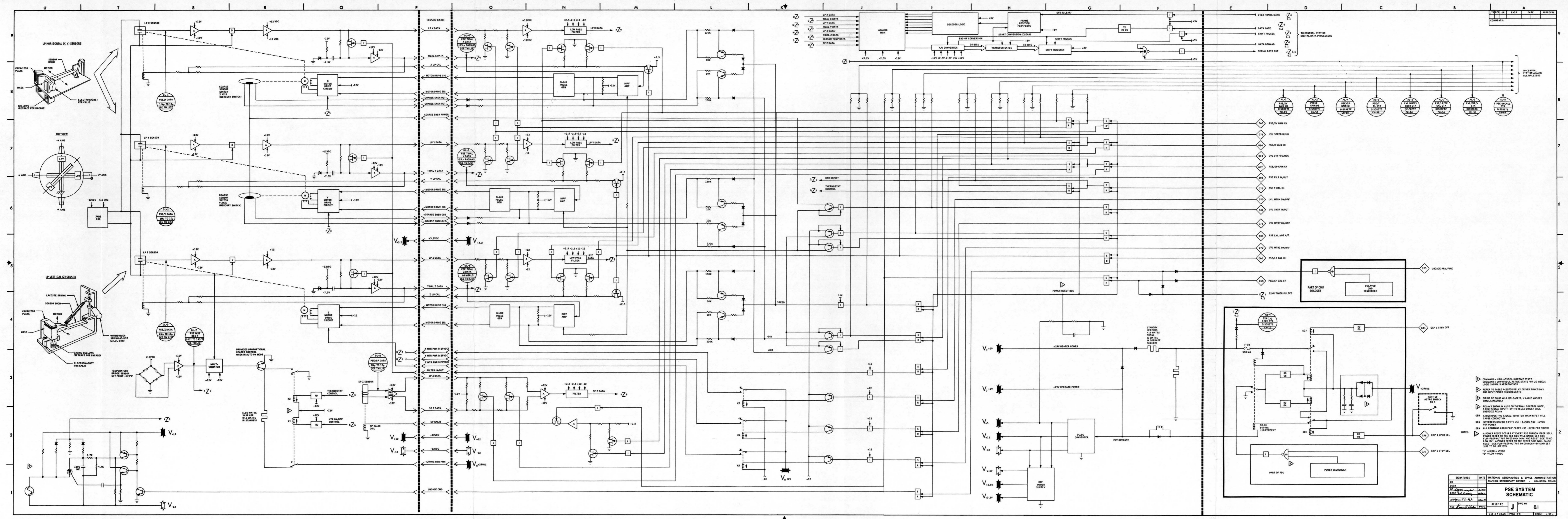

Figure 8-1. - PSE power profile.



DATE	ENGR	APPROVAL

SIGNATURES	DATE	NATIONAL AERONAUTICS & SPACE ADMINISTRATION
SE: [Signature]		MANAGED SPACECRAFT CENTER HOUSTON, TEXAS
DES: [Signature]		
APP: [Signature]		
REC: [Signature]		

**PSE SYSTEM SCHEMATIC**  
 ALSEP A2  
 8.1  
 115-5 X 50-25 PAGE 5-5 SHEET 1 OF 1

- NOTES:**
- COMMAND = HIGH (+5VDC), INACTIVE STATE COMMAND = LOW (0VDC), ACTIVE STATE FOR 50 MSEC
  - REFER TO TABLE 4-B FOR RELAY DRIVER FUNCTIONS AND INPUT POWER REQUIREMENTS
  - FIRING OF SQUIDS WILL RELEASE X, Y AND Z MASSES SIMULTANEOUSLY
  - RELAYS SHOWN IN AUTO ON THERMAL CONTROL MODE, A HIGH SIGNAL INPUT (+5V) TO RELAY DRIVER WILL ENERGIZE RELAY
  - A HIGH POSITIVE SIGNAL INPUT TO AN N PET WILL CAUSE CONVERSION
  - INVERTERS DRIVING N PETS USE +3.2VDC AND -12VDC FOR POWER
  - ALL COMMAND LOGIC FLIP-FLOPS USE +5VDC FOR POWER
  - A POWER RESET OCCURS IF EVERY FIVE THERMAL DRIVER RELAY POWER RESET TO THE SET SIDE WILL CAUSE SET SIDE FLIP-FLOP INPUT TO GO HIGH (+5V) AND RESET SIDE GO LOW (0V). A POWER RESET TO THE RESET SIDE WILL CAUSE RESET SIDE FLIP-FLOP INPUT TO GO HIGH (+5V) AND SET SIDE TO GO LOW (0V).
  - "H" = HIGH = +5VDC
  - "L" = LOW = 0VDC



SECTION 9

LUNAR SURFACE MAGNETOMETER EXPERIMENT (S034)

9.1 SYSTEM DESCRIPTION

The lunar surface magnetometer (LSM) experiment provides data pertaining to the magnitude and temporal variations of the lunar surface equatorial magnetic field vector. The LSM does this by monitoring both the dc level and time variations of the magnetic field.

Physically, the LSM consists of three magnetic sensors, each mounted in a sensor head located at the end of three mutually perpendicular axes. The sensor electronics assembly converts the incident magnetic field intensity along the axes of the respective flux gate sensors into analog voltages. The axes extend equal distances above a central structure, the electronics/gimbal-flip unit (EGFU), which houses both the experiment electronics and the gimbal-flip unit. The experiment electronics and the gimbal-flip unit. The experiment electronics are further subdivided into three functional categories: scientific data processing, engineering and status data processing, and output data buffer (see Drawing 9.3). The gimbal-flip unit houses the flipper drive motors which provide the motive power for 90 and 180-degree rotation (flipping) of the sensors and the release mechanism for the spring-driven 90-degree rotation (gimbaling) of the sensor axes. Instrument support and stability is achieved via three lunar support legs attached to the EGFU.

When the LSM is deployed by the crew, it must be leveled to within  $\pm 3$  degrees. No command capability exists in the LSM for leveling.

The temperature of the magnetic sensors is monitored and provided as data output. The LSM heaters actuation temperature is 35° C (95° F).

TABLE 9-1.- LSM PRESET CONDITIONS

["Preset" is defined as the initialized logic condition due to activation of the LSM experiment]

Command	Function	Presets to	Lunar deployment condition
043	EXP 2 STBY SEL		Exp in stby
123	LSM RANGE STEPS	±200 gamma	
124	LSM FLD O/S CH	0 percent	
125	LSM O/S ADD CH	Neutral	
127	FLIP/CAL INHIB	Inhibit	
131	FLIP/CAL GO	No-go	
132	LSM FILT IN/OUT	In	
133	SITE SURVEY XYZ	No-go	
134	LSM T CTL XYO	X	

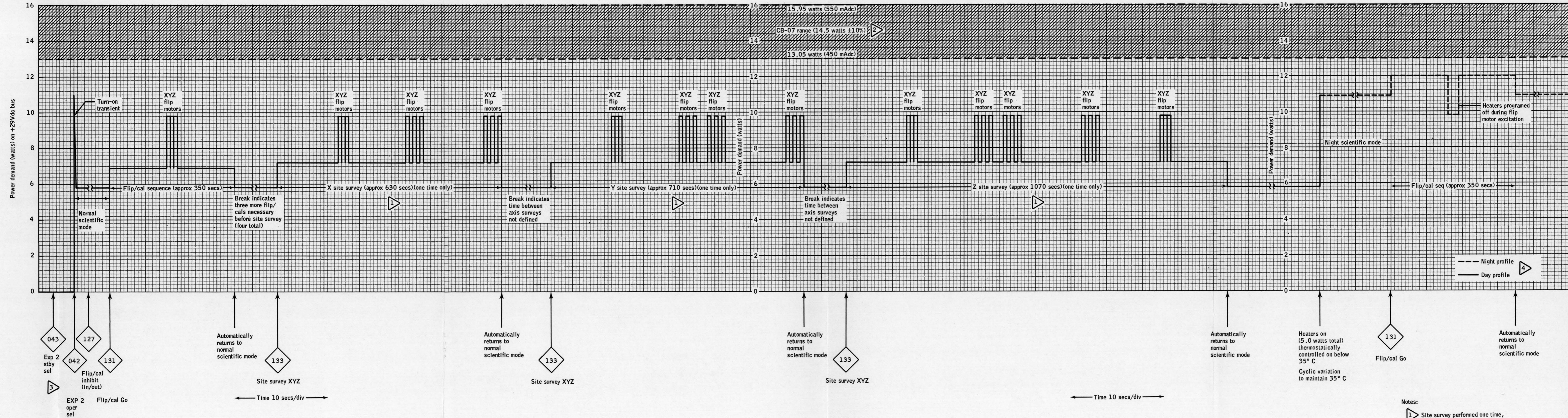

- Notes:
- 1 Site survey performed one time, during lunar day
  - 2 CB-07 protects operational power line. Operating spec is 500 mA ±10%
  - 3 LSM has no standby power demand
  - 4 Temperature assumed to be above +35° C. If below, add 5 watts for heater power. Heaters automatically programmed off during flip motor on time

Figure 9-1.- LSM power profile.

\*

## 9.2 FLIP-CALIBRATION SEQUENCE (See Drawing 9.1)

The purpose of the flip-cal sequence is to prevent permanent magnetization of the sensors due to lunar magnetic fields. The flip-cal sequence further inserts calibration rasters of known levels to provide baseline data with which to compare lunar magnetic fields.

The flip-cal sequence can be initiated by Ground Command 131 (FLIP/CAL GO), or by an automatically generated command via the ALSEP timer at the ninth 18-hour pulse plus 1 minute and every 18 hours thereafter.

The flip-cal sequence can be inhibited by means of Ground Command 127 (FLIP/CAL INHIB), which prevents the initiation of the flip-cal sequence from either ground command or ALSEP timer-generated command.

The sequence, once initiated, is completely controlled by the LSM flip-cal programmer and cannot be terminated by ground command. The sequence is completed in approximately 350 seconds.

The programmer causes all necessary events to occur in the following order:

- A. Upon receipt of the flip-cal command, two calibration rasters are applied to all sensors (X, Y, and Z) simultaneously for 160 seconds (refer to Drawing 9.1).
- B. The programmer then flips all sensors sequentially 180 degrees and applies reverse field offset bias to each sensor.
- C. Upon completion of the flip action of the three sensors (30 seconds total, 10 seconds per sensor), the programmer applies two more calibration rasters to all three sensors simultaneously for 160 seconds.

\*

ALSEP A2  
BASIC

D. Following the last calibration raster, the programmer stops the flip-cal sequence generator, at which time the LSM is in the normal scientific mode.

The result of the flip-cal sequence is that the sensors are now oriented diametrically opposite in direction, with field offset bias of opposite polarity to that prior to the initiation of the flip-cal sequence.

GAMMA RANGE	SENSOR POSITION	% OFFSET						
		0	+25	+50	+75	-75	-50	-25
50	0° OR 90°	+50	+62.5	+75	+87.5	+12.5	+25	+37.5
	180°	-50	-62.5	-75	-87.5	-12.5	-25	-37.5
100	0° OR 90°	+100	+125	+150	+175	+25	+50	+75
	180°	-100	-125	-150	-175	-25	-50	-75
200	0° OR 90°	+200	+250	+300	+350	+50	+100	+150
	180°	-200	-250	-300	-350	-50	-100	-150

LSM EFFECTIVE RANGES AS A FUNCTION OF OFFSET AND SENSOR POSITION

SENSOR POSITION			
DM-9	DM-10	DM-11	Z
01 (0°)	✓	✓	✓
10 (90°)	✓	✓	✓
00 (FAIL)			

SENSOR POSITION			
DM-9	DM-10	DM-11	Z
01 (0°)	✓	✓	✓
10 (90°)	✓	✓	✓
11 (180°)	✓	✓	✓
00 (FAIL)			

SENSOR POSITION			
DM-9	DM-10	DM-11	Z
01 (0°)	✓	✓	✓
10 (90°)	✓	✓	✓
11 (180°)	✓	✓	✓
00 (FAIL)			

SENSOR POSITION			
DM-9	DM-10	DM-11	Z
01 (0°)	✓	✓	✓
10 (90°)	✓	✓	✓
11 (180°)	✓	✓	✓
00 (FAIL)			

SENSOR POSITION			
DM-9	DM-10	DM-11	Z
01 (0°)	✓	✓	✓
10 (90°)	✓	✓	✓
11 (180°)	✓	✓	✓
00 (FAIL)			

SCIENTIFIC ORIENTATION AFTER FLIP CAL SEQ NO 1 (180 DEGREES)

SENSOR POSITION			
DM-9	DM-10	DM-11	Z
01 (0°)	✓	✓	✓
10 (90°)	✓	✓	✓
11 (180°)	✓	✓	✓
00 (FAIL)			

SCIENTIFIC ORIENTATION AFTER FLIP CAL SEQ NO 2 (0 DEGREES)

SENSOR POSITION			
DM-9	DM-10	DM-11	Z
01 (0°)	✓	✓	✓
10 (90°)	✓	✓	✓
11 (180°)	✓	✓	✓
00 (FAIL)			

SCIENTIFIC ORIENTATION AFTER FLIP CAL SEQ NO 3 (180 DEGREES)

SENSOR POSITION			
DM-9	DM-10	DM-11	Z
01 (0°)	✓	✓	✓
10 (90°)	✓	✓	✓
11 (180°)	✓	✓	✓
00 (FAIL)			

SCIENTIFIC ORIENTATION AFTER FLIP CAL SEQ NO 4 (0 DEGREES)

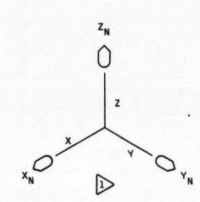

INITIAL SCIENTIFIC ORIENTATION (0 DEGREES)

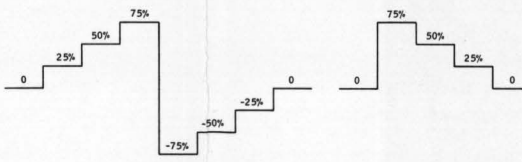

FIELD OFFSET  
ANY OF THE ABOVE OFFSET STEPS CAN BE SELECTED FOR ANY OF THE 3 AXES. STEPS LISTED IN PERCENT OF RANGE SELECTED.

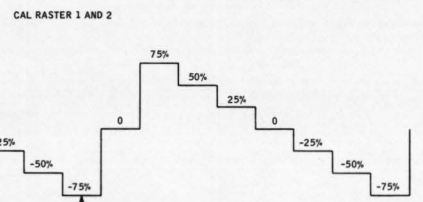

CAL RASTER 1 AND 2  
CAL STEPS APPROX 10 SEC DURATION EACH STEP. STEPS LISTED IN PERCENT OF RANGE SELECTED.

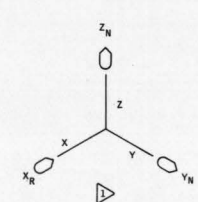

FLIP X AXIS REVERSE FIELD OFFSET. NEW OFFSET X<sub>r</sub>

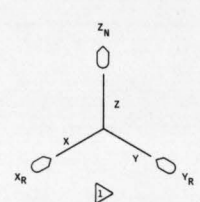

FLIP Y AXIS REVERSE FIELD OFFSET. NEW OFFSET Y<sub>r</sub>

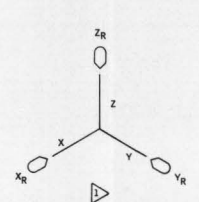

FLIP Z AXIS REVERSE FIELD OFFSET. NEW OFFSET Z<sub>r</sub>

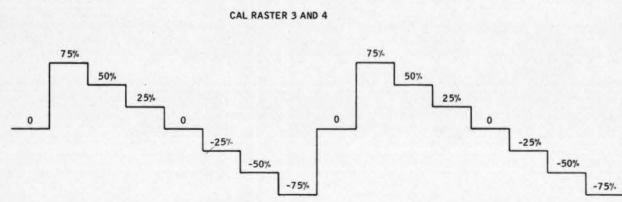

FLIP X AXIS REVERSE FIELD OFFSET. NEW OFFSET X<sub>r</sub>

FLIP Y AXIS REVERSE FIELD OFFSET. NEW OFFSET Y<sub>r</sub>

FLIP Z AXIS REVERSE FIELD OFFSET. NEW OFFSET Z<sub>r</sub>

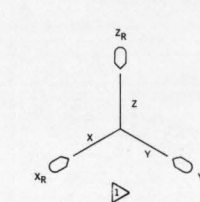

SCIENTIFIC ORIENTATION AFTER FLIP CAL SEQ NO 1 (180 DEGREES)



SCIENTIFIC ORIENTATION AFTER FLIP CAL SEQ NO 2 (0 DEGREES)

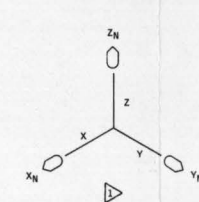

SCIENTIFIC ORIENTATION AFTER FLIP CAL SEQ NO 3 (180 DEGREES)

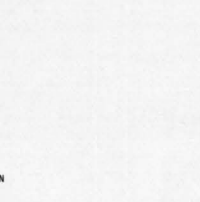

SCIENTIFIC ORIENTATION AFTER FLIP CAL SEQ NO 4 (0 DEGREES)

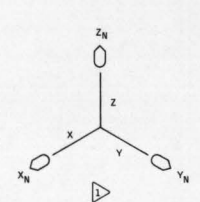

SCIENTIFIC ORIENTATION AFTER FLIP CAL SEQ NO 4 (0 DEGREES)

READY FOR X-AXIS SITE SURVEY

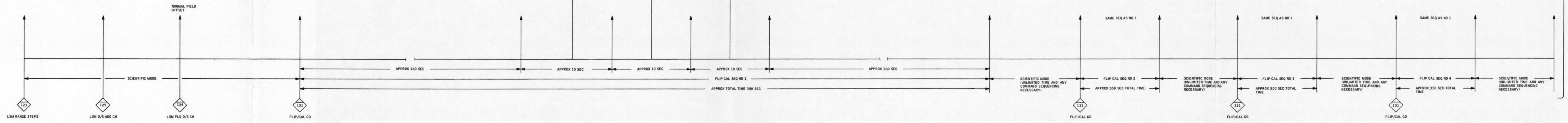

NOTE:  
X<sub>n</sub> = X AXIS FIELD OFFSET NORMAL  
X<sub>r</sub> = X AXIS FIELD OFFSET REVERSED  
Y<sub>n</sub> = Y AXIS FIELD OFFSET NORMAL  
Y<sub>r</sub> = Y AXIS FIELD OFFSET REVERSED  
Z<sub>n</sub> = Z AXIS FIELD OFFSET NORMAL  
Z<sub>r</sub> = Z AXIS FIELD OFFSET REVERSED

SIGNATURES	DATE	NATIONAL AERONAUTICS & SPACE ADMINISTRATION
DR	7/1/70	MANHATTAN SPACECRAFT CENTER - HOUSTON, TEXAS
ENGR	7/1/70	
APPROVED	7/1/70	
FEC	7/1/70	

LSM FLIP CALIBRATION SEQUENCE

\*

### 9.3 SITE-SURVEY SEQUENCE (Refer to Drawing 9.2)

The site-survey sequence is performed upon completion of the first four flip-cal sequences and will be performed only once during the life of the instrument. The purpose of the site-survey sequence is to measure local accretions of nickel-iron or stony-iron meteoric debris.

#### 9.3.1 X-Axis Site Survey Sequence

Initiation of Ground Command 133 (SITE SURVEY XYZ) simultaneously applies power to the site-survey programmer and to the flip-cal programmer. Once the sequence is initiated, it cannot be terminated by ground command. The site-survey is completed in approximately 630 seconds.

Upon receipt of the site-survey command, the programmer is sequenced to an idle state. The programmer then sequences the sensors through a normal flip-cal sequence. Upon completion of the flip-cal sequence, the programmer flips all sensors sequentially so that they are surveying the X-axis and applies the X field offset bias to each sensor. On completion of the flip action, the programmer places the instrument into X site survey state. Upon completion of site survey, the programmer sequentially flips all sensors back to the previous position and reverses and reinstates the previous field offset bias to each sensor.

#### 9.3.2 Y-Axis Site Survey Sequence

Upon initiation by Ground Command 133, power is simultaneously applied to both the site survey and flip-cal programmers. Site survey cannot be terminated by ground command and completes its sequence in approximately 710 seconds.

\*

On receipt of the command, the programmer is sequenced to an idle state. The programmer then sequences the sensors through a normal flip-cal sequence, with one exception: during the flip-cal sequence the Y- and Z-axis sensor assemblies are gimbaled (90-degree longitudinal rotation). Upon completion of the flip-cal sequence, the programmer flips all sensors sequentially 180 degrees and applies reverse field offset bias to each sensor. After completion of the 180-degree flip action, the programmer flips all sensors sequentially so that they are surveying the Y-axis and applies the Y field offset bias to each sensor. On completion of the flip action, the programmer places the instrument into Y site survey state. Upon completion of site survey, the programmer sequentially flips all sensors back to the previous position and reverses and reinstates the previous field offset bias to each sensor.

### 9.3.3 Z-Axis Site Survey Sequence

Initiation by Ground Command 133 is identical to the previous site survey initiations. The Z-axis site survey completes its sequence in 1070 seconds. Upon receipt of the site-survey command, the programmer is sequenced to an idle state. The programmer then sequences the sensors through a normal flip-cal sequence, with one exception: during the flip-cal sequence the X-axis sensor assembly is gimbaled (90-degree longitudinal rotation). Upon completion of the flip-cal sequence, the programmer flips all sensors sequentially 180 degrees and applies reverse field offset bias to each sensor. On completion of the 180-degree flip action, the programmer again flips all sensors sequentially so that they are surveying the Z-axis and applies the Z field offset bias to each sensor. On completion of the flip action, the programmer places the instrument into Z site survey state. Upon



\*

completion of site survey, the programmer sequentially flips all sensors back to the previous position and reverses and reinstates the previous field offset bias to each axis. On completion of sensor reinstatement two calibration rasters are applied to all sensors simultaneously. The programmer then flips all sensors sequentially 180 degrees and applies reverse field offset bias to each sensor. The programmer then flips all sensors (X, Y, and Z) simultaneously 180 degrees and applies simultaneously reverse field offset bias to each sensor. Upon completion of the flip action of the three sensors, the programmer applies two more calibration rasters to all three sensors simultaneously. Following the last calibration raster, the programmer stops the site-survey sequence, at which time the LSM is in the normal scientific mode.

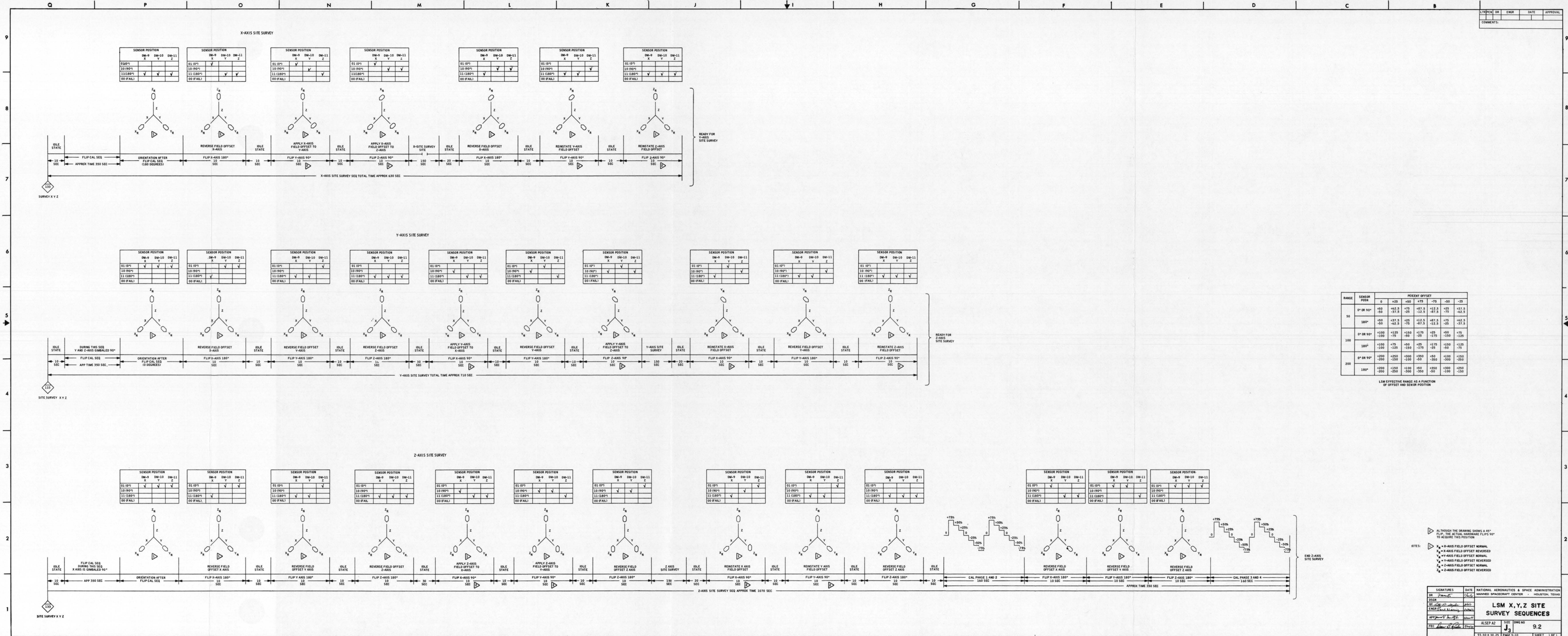

RANGE	SENSOR POSN	RECENT OFFSET						
		0	+25	+50	+75	-75	-50	-25
50	0° OR 90°	+50	+62.5	+75	+87.5	+112.5	+125	+137.5
	180°	-50	-62.5	-75	-87.5	-112.5	-125	-137.5
100	0° OR 90°	+100	+125	+150	+175	+225	+250	+275
	180°	-100	-125	-150	-175	-225	-250	-275
200	0° OR 90°	+200	+250	+300	+350	+450	+500	+550
	180°	-200	-250	-300	-350	-450	-500	-550

LSM EFFECTIVE RANGE AS A FUNCTION OF OFFSET AND SENSOR POSITION

- NOTES:
- ▲ ALTHOUGH THE DRAWING SHOWS A 45° FLIP, THE ACTUAL HARDWARE FLIPS 90° TO ACQUIRE THIS POSITION
  - ▽ X-AXIS FIELD OFFSET NORMAL
  - ▾ X-AXIS FIELD OFFSET REVERSED
  - Y-AXIS FIELD OFFSET NORMAL
  - Y-AXIS FIELD OFFSET REVERSED
  - Z-AXIS FIELD OFFSET NORMAL
  - ▻ Z-AXIS FIELD OFFSET REVERSED

SIGNATURES	DATE	NATIONAL AERONAUTICS & SPACE ADMINISTRATION
DR	ENGR	MANNED SPACECRAFT CENTER - HOUSTON, TEXAS
DISG		
ENGR		
APPROVED		
FEC		

**LSM X, Y, Z SITE SURVEY SEQUENCES**

ALSEP A2     SIZE J3     DWG NO 9.2  
93.50 X 30.25     PAGE 1-10     SHEET 1 OF 1

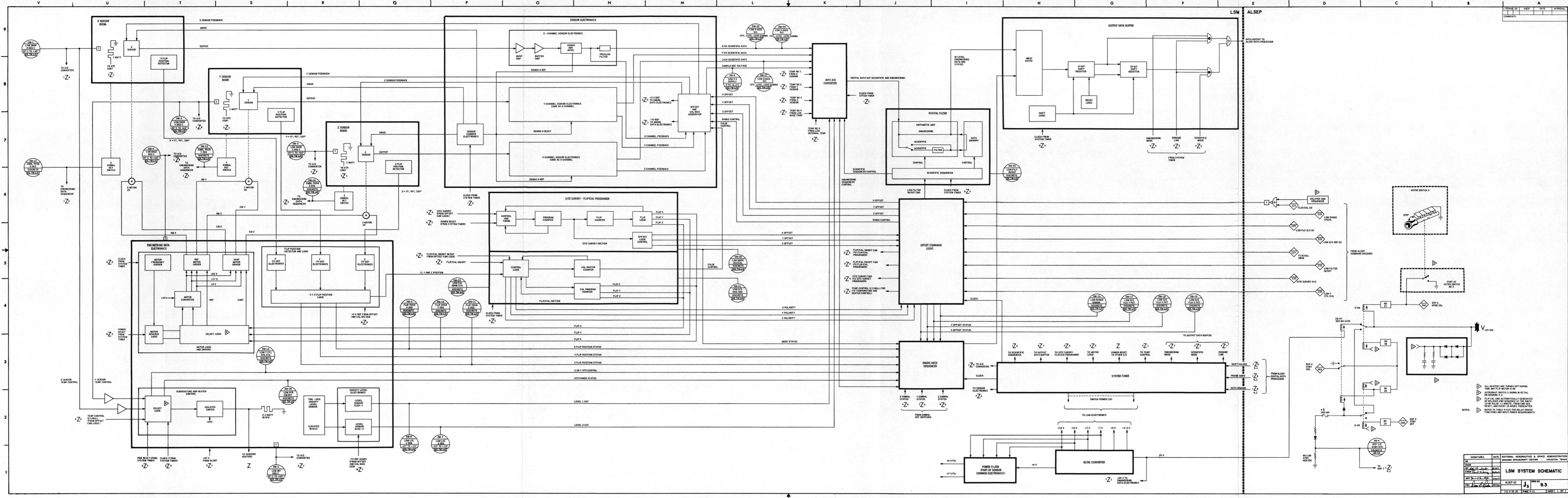

DATE	APPROVAL

DATE	NATIONAL AERONAUTICS & SPACE ADMINISTRATION

**LSM SYSTEM SCHEMATIC**

REV: 1.0  
 DATE: 12/15/73  
 DRAWN BY: J.S.  
 CHECKED BY: J.S.  
 TITLE: LSM SYSTEM SCHEMATIC

NOTES:

- ALL HEATERS ARE TURNED OFF DURING TIME ANY FLIP MOTOR IS ON.
- ALTERNATE SWITCHES 3 SHOWN IN DETAIL ON DRAWING 4.2.
- FLIP CAL. CMD. IS AUTOMATICALLY GENERATED BY DELAYED CMD SEQUENCE AT THE START OF THE FLIP. 15 MINUTE FROM CMD SEC. RESET, AND EVERY 15 HOURS THEREAFTER REFER TO TABLE 4-11 FOR DELAY SEQUENCE FUNCTIONS AND INPUT POWER REQUIREMENTS.

\*

SECTION 10  
SOLAR WIND SPECTROMETER EXPERIMENT (S-035)

10.1 SYSTEM DESCRIPTION

The solar wind spectrometer (SWS) experiment provides data pertaining to certain properties of the solar wind plasma as it exists at the lunar surface. It measures temporal and directional variations in the flux and energy of positive ions and electrons that strike the lunar surface.

The basic sensor in the SWS is a Faraday cup which measures the charged particle flux by collecting these ions and using a very sensitive current amplifier to determine the resulting current flow. The SWS contains seven of these cups arranged in a uniformly geometric fashion that allows flux measurements to be taken above the horizon. This also allows measurement of the angular distribution of the ion flux. One cup is oriented to face vertically, and the remaining six cups are arranged around this vertical cup such that the normals between any two adjacent cups are at an angle of approximately 1 radian.

The operation of the SWS in measuring the charged particles of the solar wind may be classified into five functional activities. These functions are sequencing, sensor excitation, measurement, data handling, and power supply.

A. Sequencing - The sequencing function controls internal handling and processing and generates the internal commands for sequencing various data, calibration, and housekeeping inputs. The sequencing function controls the following:

1. The preamplifier switch that connects any one, or all, of the preamplifiers to the input of the current measurement chain

\*

2. The voltage applied by the sensor excitation function to the modulator grids of the sensors to select the proper polarity and energy band of particles to be measured
  3. Solid-state switches so that the gain of the current measuring chain, the magnitude of critical voltages, temperatures, and calibration data for the analog-to-digital converter can be read into the telemetry to check circuit operation and changes in calibration
- B. Sensor excitation - The sensor excitation function is a high-voltage generator which produces a set of discrete dc voltage outputs between approximately -1000 and +8000 Vdc and a set of discrete square-wave ac voltages with half amplitudes between approximately 5 and 1400 Vac. Under the control of the sequencing function, it applies combinations of these voltages to the sensor-cup modulator grid in such a way as to cover the expected solar wind energy regions for protons and electrons. Two distinct sets of voltages can be selected by a ground command which change the amplifier's gain by the factor 1.68.
- C. Measurement - The measurement function includes the particle sensors, temperature sensors, sun sensor, and signal chain. The signal chain is a series of electronic circuits which amplify and demodulate the currents from the seven sensor collectors. Under control of the sequencing function, the signal chain selects the collector current to be measured or linearly sums all seven currents.
- D. Data handling - The data handling function accepts analog measurement data, performs analog-to-digital conversion, and provides the data to the ALSEP DSS upon demand.

\*

E. Power supply - The power supply converts the ALSEP bus power of 29-volt regulated dc into the appropriate dc voltages needed for the SWS. It includes a dc-to-ac inverter, rectifier, control circuits, and transformer. It provides dc isolation for the SWS from the ALSEP power lines.

The SWS operational heater actuation temperature is 20° C (68° F).

The SWS is initialized the low-gain mode. To place the instrument in the high-gain mode, transmit Command 122 (SWS CVR GO) three times within 10 seconds. This causes the electron and proton measurement voltage levels to increase by a factor of 1.68 over the low-gain mode. To return to low gain, place SWS to standby select, then to operate select.

10-4

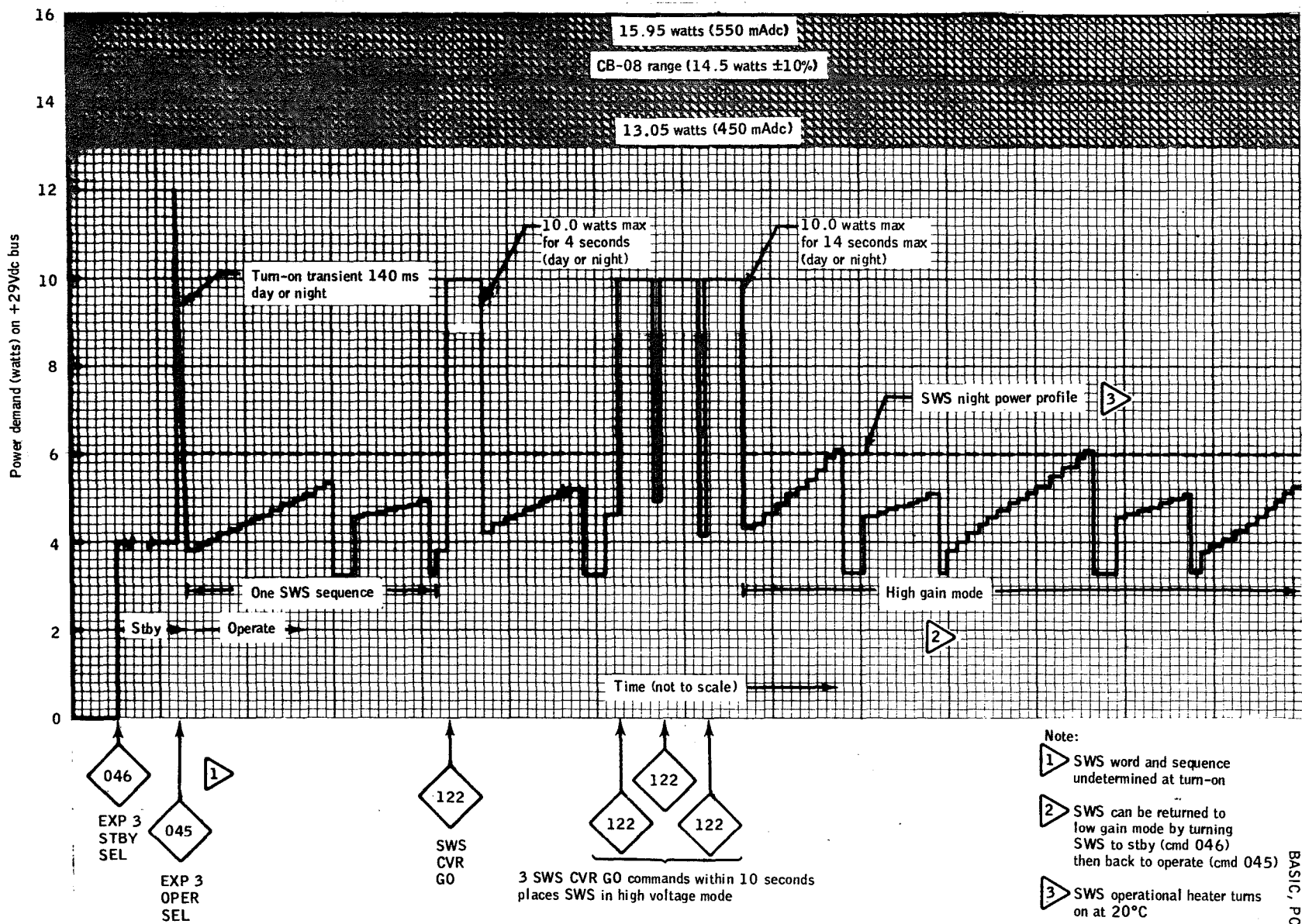
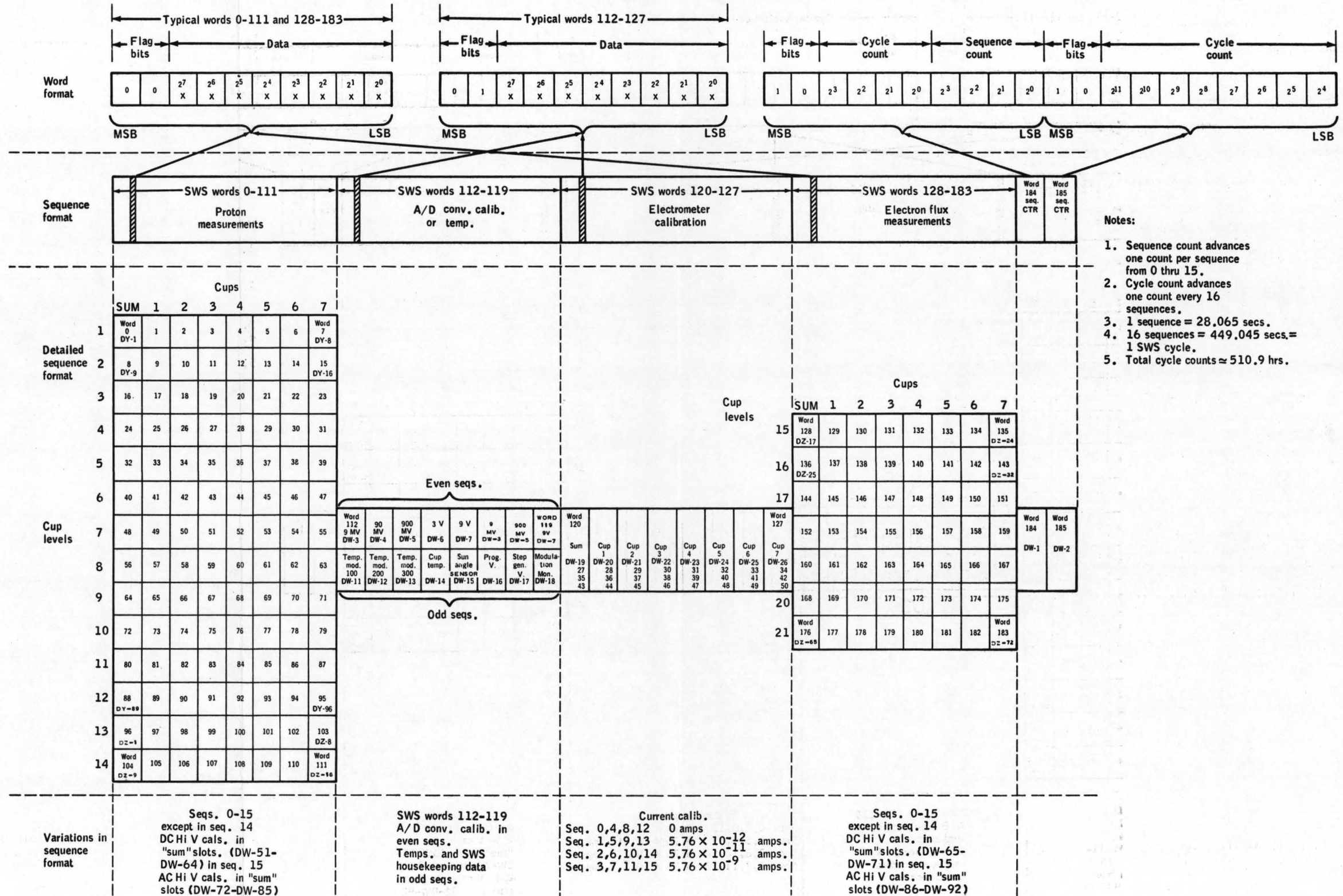

Figure 10-1. - SWS power profile.



- Notes:**
1. Sequence count advances one count per sequence from 0 thru 15.
  2. Cycle count advances one count every 16 sequences.
  3. 1 sequence = 28.065 secs.
  4. 16 sequences = 449.045 secs. = 1 SWS cycle.
  5. Total cycle counts ≈ 510.9 hrs.

Figure 10-2.- SWS telemetry format.



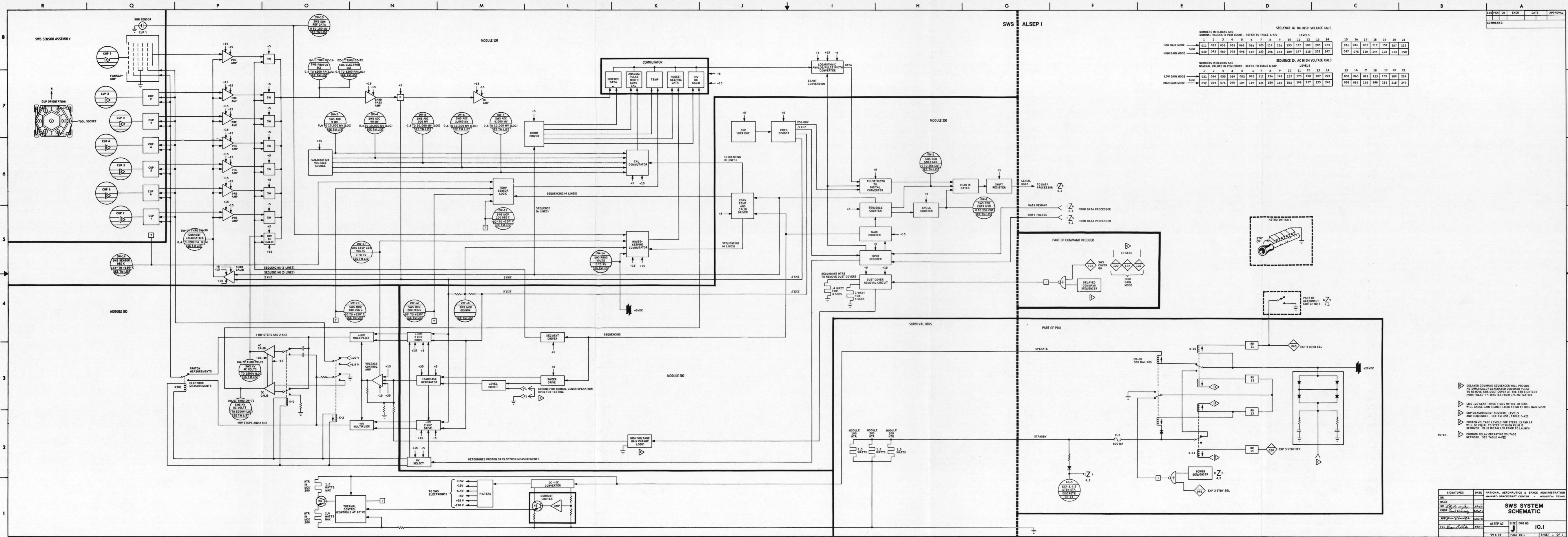

SEQUENCE 14, DC HIGH VOLTAGE CALS

LEVELS	1	2	3	4	5	6	7	8	9	10	11	12	13	14	15	16	17	18	19	20	21
LOW GAIN MODE	011	013	031	051	066	086	103	119	136	153	170	188	205	223	016	046	082	117	152	187	222
HIGH GAIN MODE	030	043	060	078	095	112	130	146	163	180	197	215	231	247	047	075	110	144	178	214	250

SEQUENCE 15, AC HIGH VOLTAGE CALS

LEVELS	1	2	3	4	5	6	7	8	9	10	11	12	13	14	15	16	17	18	19	20	21
LOW GAIN MODE	051	064	055	069	082	095	111	126	141	157	173	190	207	224	038	063	092	123	155	189	224
HIGH GAIN MODE	052	064	076	090	104	119	135	150	166	182	199	217	233	248	058	086	116	148	181	215	249

- NOTES:
- ▷ DELAYED COMMAND SEQUENCER WILL PROVIDE AUTOMATICALLY GENERATED COMMAND PULSE TO REMOVE SWS DUST COVER AT THE FIFTEEN HOUR PULSE + 4 MINUTES FROM C/S ACTIVATION
  - ▷ CMD 122 SENT THREE TIMES WITHIN 10 SECS WILL CAUSE GAIN CHANGE LOGIC TO GO TO HIGH GAIN MODE
  - ▷ CUP MEASUREMENT NUMBERS, LEVELS AND SEQUENCES - SEE TM LIST, TABLE 6-XIII
  - ▷ PROTON VOLTAGE LEVELS FOR STEPS 13 AND 14 WILL BE EQUAL TO STEP 12 WHEN PLUG IS REMOVED. PLUG INSTALLED PRIOR TO LAUNCH
  - ▷ COMMON RELAY OPERATING VOLTAGE NETWORK - SEE TABLE 4-VII

\*

SECTION 11

SUPRATHERMAL ION DETECTOR EXPERIMENT/COLD  
CATHODE GAGE EXPERIMENT (S-036)

11.1 SYSTEM DESCRIPTION

The suprathemal ion detector experiment (SIDE) will provide data pertaining to the density and the temperature of the lunar ionosphere as it exists near the lunar surface. SIDE measurements include ion counts as well as measurement of the velocity and the energy associated with the detected particles. The cold cathode gage experiment (CCGE) will determine the neutral particle density at the lunar surface and any variations in that density associated with solar activity. Specifically, the CCGE will measure the density and temperature of the lunar environment, from which pressure is derived.

The low-energy particle sensor used in the SIDE has a velocity filter composed of crossed electric and magnetic fields followed by a low-energy curved-plate analyzer. The velocity filter passes ions with proper velocities, and the low-energy curved-plate analyzer passes ions with the proper energy. The particles that pass through the curved-plate analyzer are detected and counted. The velocity filter selects ions with velocities ranging from  $4 \times 10^4$  to  $9.35 \times 10^6$  cm/sec. The low-energy curved-plate analyzer covers an energy range of 0.2 to 48.6 eV per unit charge. The instrument also contains a high-energy curved-plate analyzer without a velocity filter that detects and counts solar wind particles in the range from 10 to 3500 eV per unit charge.

In order to overcome electric fields that may be present at the lunar surface, the instrument rests on a ground plane. This ground plane consists of a wire mesh which is spread out on the lunar surface by the crewman. A power supply in the instrument

\*

ALSEP A2  
BASIC

applies voltage between the instrument electronics and the ground plane to investigate and overcome any electric field effects.

The velocity filter, low-energy curved-plate analyzer, high-energy curved-plate analyzer, and ground plane voltages are controlled in steps by the SIDE timing and SIDE frame counter circuits to allow measurements of particle velocity and energy within the given ranges. Relative values of these functions with respect to SIDE frame number are shown in Figures 11-2 through 11-5.

The CCGE consists of a cold cathode ion gage (CCIG) and its associated electronics. These are mounted in the same package as the suprathemal ion detector experiment during the flight to the moon. When the crewman deploys the package, he removes the CCIG and places it a few feet away from the SIDE. An electrical cable connects the CCIG to the SIDE. The ion gage produces an electrical current that is proportional to the measured pressure over the desired pressure range of  $10^{-6}$  to  $10^{-12}$  torr. This current is amplified and read out as the experiment scientific data.

Upon deployment by the crew, the SIDE is to be leveled within  $\pm 5$  degrees. No command capability exists in the SIDE to command leveling.

The SIDE heater actuation temperature is  $0^{\circ} \pm 8^{\circ} \text{ C}$  ( $32^{\circ} \text{ F}$ ).

TABLE 11-I.- SIDE/CCGE PRESET CONDITIONS

Activation will cause the following functions to be preset:

- Velocity Filter Voltage to ON
- HECPA High Voltage to ON
- LECPA High Voltage to ON
- Channeltron High Voltage to ON
- CCIG High Voltage to ON
- Resets all Command Flip-Flops
- Resets SIDE Frame Counter
- Resets Velocity Filter Counter
- Resets HECPA Counter
- Resets LECPA Counter
- Resets Ground Plane Counter,  
Step Programmer ON
- Causes Normal Mode (128 SIDE Frames cycle)  
to be outputted, X10 Accumulation OFF

NOTE

"Preset" is defined as logic condition due to the activation (OPERATE SELECT) of the SIDE/CCGE.

TABLE 11-II.- GROUND PLANE STEPPER SEQUENCE

SIDE/CCGE Cycle Number	DI-63	DI-11
	Ground Plane Step Reading	Ground Plane Voltage (volts)
0	0	0
1	1	+0.6
2	2	+1.2
3	3	+1.8
4	4	+2.4
5	5	+3.6
6	6	+5.4
7	7	+7.8
8	8	+10.2
9	9	+16.2
10	10	+19.8
11	11	+27.6
12	16	0
13	17	-0.6
14	18	-1.2
15	19	-1.8
16	20	-2.4
17	21	-3.6
18	22	-5.4
19	23	-7.8
20	24	-10.2
21	25	-16.2
22	26	-19.8
23	27	-27.6
0	0	0
↓	↓	↓
23	27	-27.6

TABLE 11-III.- SIDE WORD 2 TELEMETRY

Telemetry Point <u>VOLTAGES</u>	SIDE Frame 0	Reset SIDE Frame Counter at 10	Reset SIDE Frame Counter at 39	Reset SIDE Frame Counter at 79
DI2 (+5 V ANALOG)	0	32	64	96
DI7 (+4.5 KV)	8		40,72	104
DI13 (+60 V)		16	48	80,112
DI14 (+30 V)		17	49	81,113
DI15 (+5 V DIGITAL)		18	50	82,114
DI16 (GND)		19	51	83,115
DI17 (-5 V)		20	52	84,116
DI18 (-30 V)		21	53	85,117
DI20 (-3.5 KV)		23	55	87,119
DI21 (+1 V CAL)		27	59	91
DI22 (+30 MV CAL)		25	57	89
DI23 (+A/D REF)		26	58	90
DI25 (-A/D REF)		30	62	94
DI26 (-1 V CAL)		37		101
DI27 (-12 V CAL)		39		103
DI28 (+12 V CAL)		28	60	92
DI30 (-30 MV CAL)			46	110
<u>TEMPERATURES</u>				
DI4 (1-CCIG)	2	34	66	98
DI5 (2-200 BLIVET)	4	36	68	100
DI6 (3-500 BLIVET)	6	38	70	102
DI9 (4-100 BLIVET)		11	43,75	107
DI10 (5-300 BLIVET)		12	44,76	108
DI19 (6-800 BLIVET)		22	54	86,118
<u>DATA &amp; MISC</u>				
DF29 (O/T CMD LOAD)		33,35		97,99
DI3 (CCGE SCIENCE DATA)	1,3,5,7,9		41,73	105,121-127
DI8 (CCGE RANGE)	10	24	42,56,74	88,106,120
DI11 (GND PLANE VOLTS)		13,15,29,31	45,47,61,63,69,77,79	93,95,109,111
DI12 (SOLAR CELL OUTPUT)		14	78	
DI24 (DUST CVR/SEAL)			67,71	
DI29 (PRE/REG PCT)			65	

NOTE

SIDE turn-on will initialize all command registers to their preset state. TM parameters DF-29 (SIDE O/T CMD LOAD), DI-24 (SIDE/A CVR/S STA), and DI-66 (SIDE/D CVR/S STA) will indicate PRESET. The first transmission of any command sequence containing commands 105 and 110, after turn-on, will cause DF-29, DI-24, and DI-66 to indicate that the seal has been broken. The first transmission of any command sequence containing commands 107 and 110, after turn-on, will cause DF-29, DI-24, DI-66 to indicate that the dust cover has been removed. Seal break circuit activation causes no additional power demand. However, the dust cover circuit activation will cause an increase in power demand of 6 watts. The SIDE operational heater power is interrupted during the dust cover circuit activation time (approximately 2.5 seconds) to prevent SIDE circuit breaker CB-09 from actuating. Further transmission of command sequences containing commands 105 and 107 will have no effect on the seal break circuit, dust cover removal circuit, or TM parameters DF-29, DI-24, and DI-66. (Refer to Figure 11-1.)

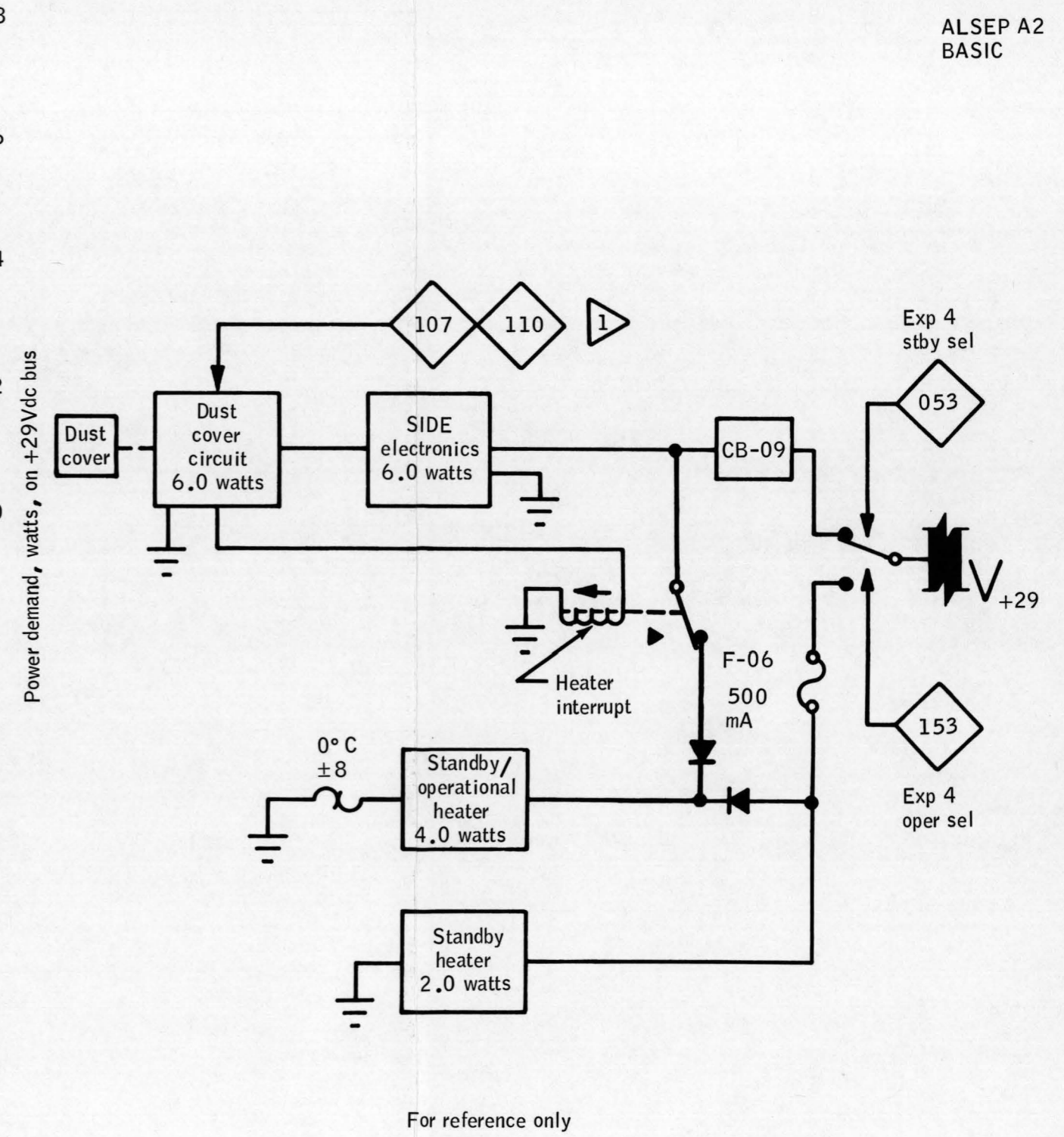
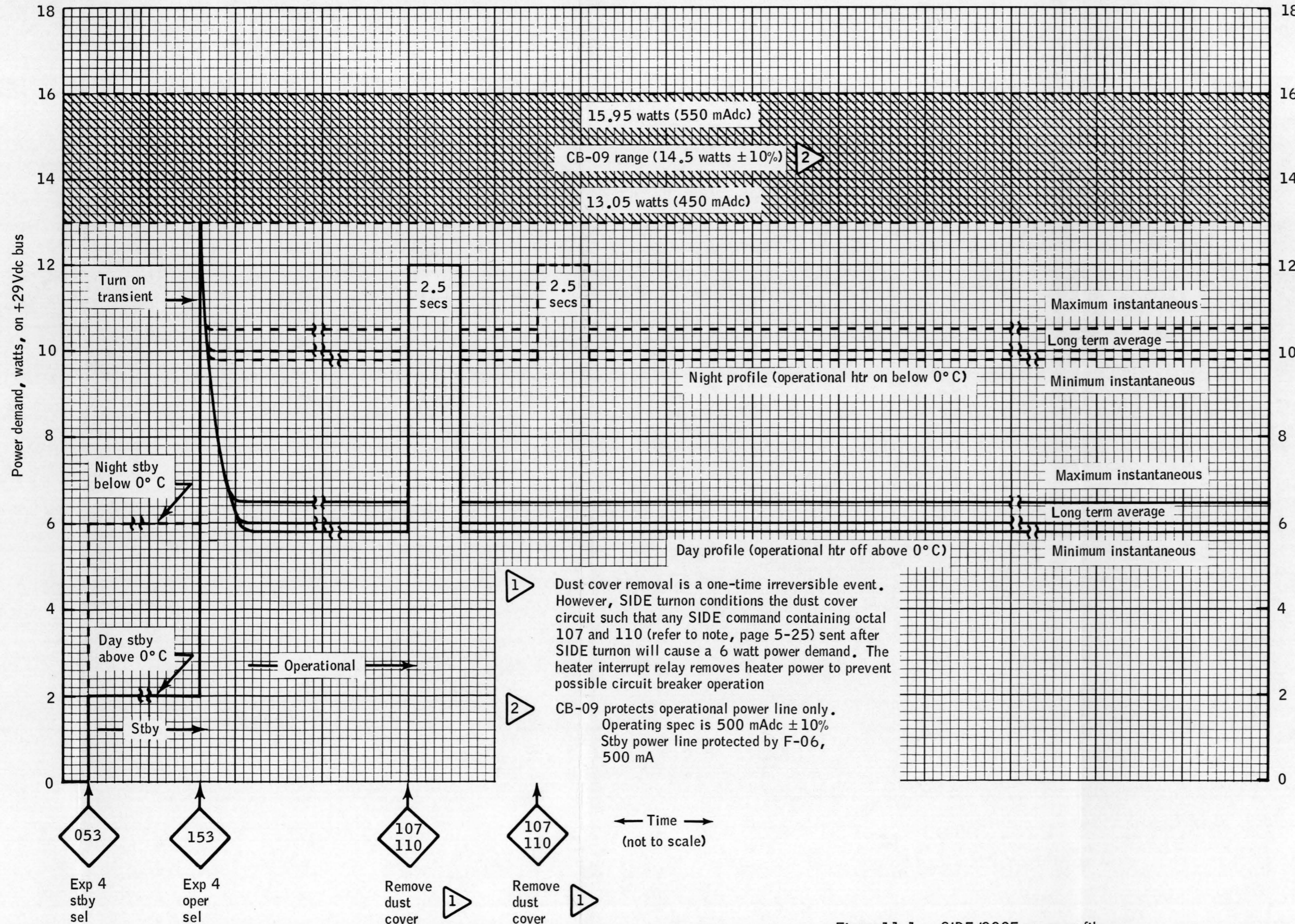

Figure 11-1. - SIDE/CCGE power profile.

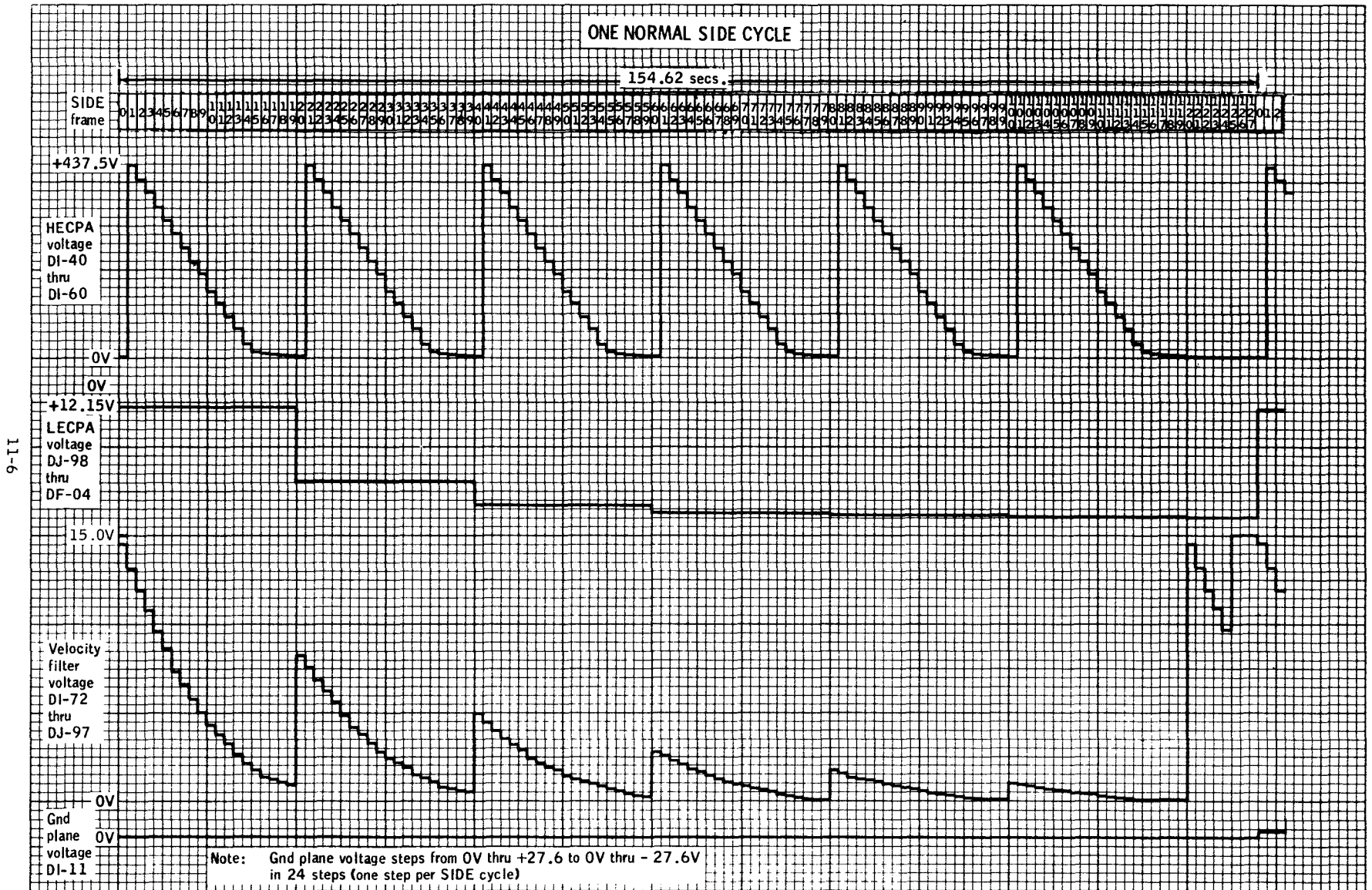

Figure 11-2. - Programed sensor voltage variations (normal cycle).

11-6

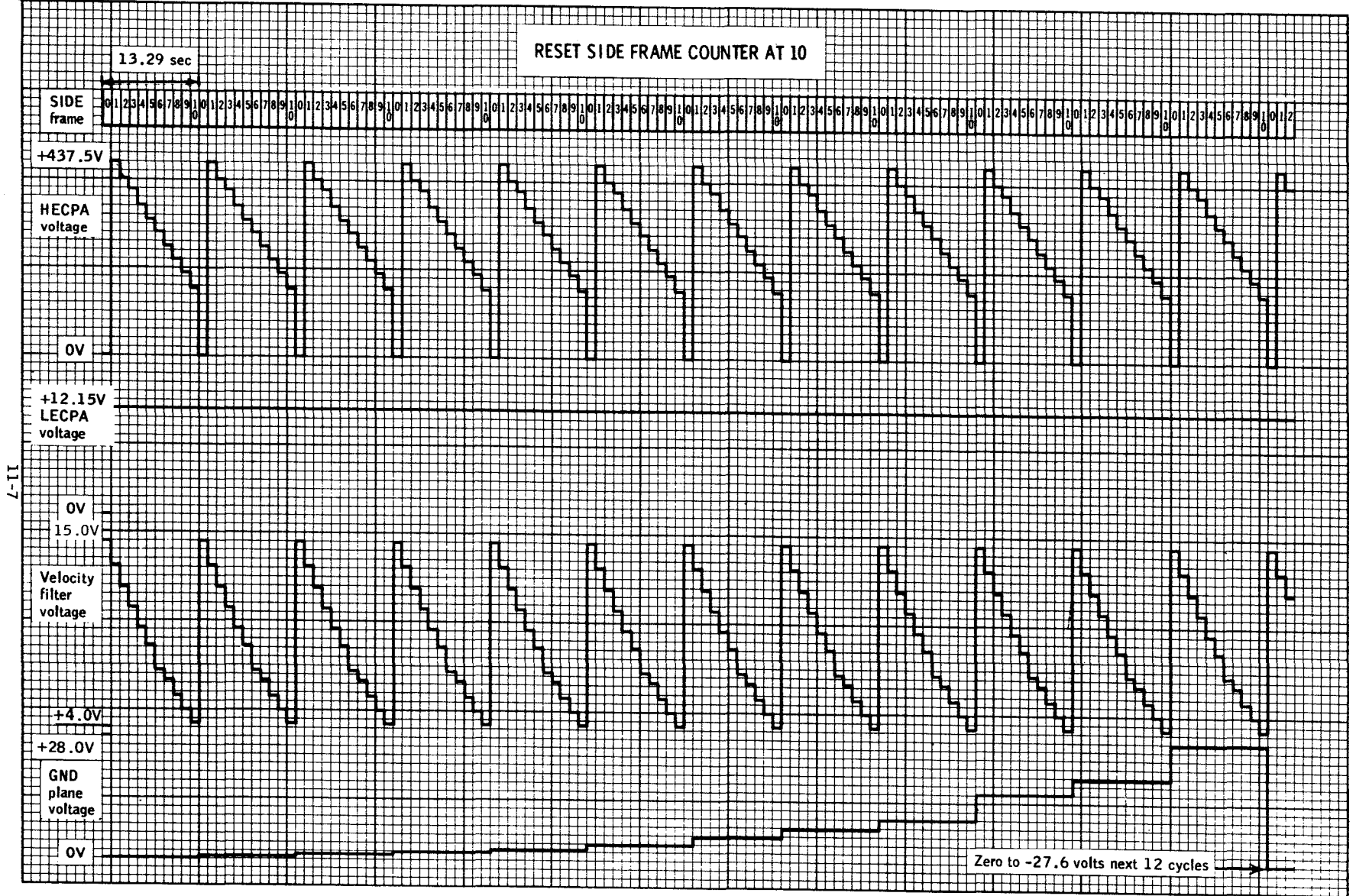

Figure 11-3. - Programed sensor voltage variations (reset at 10).



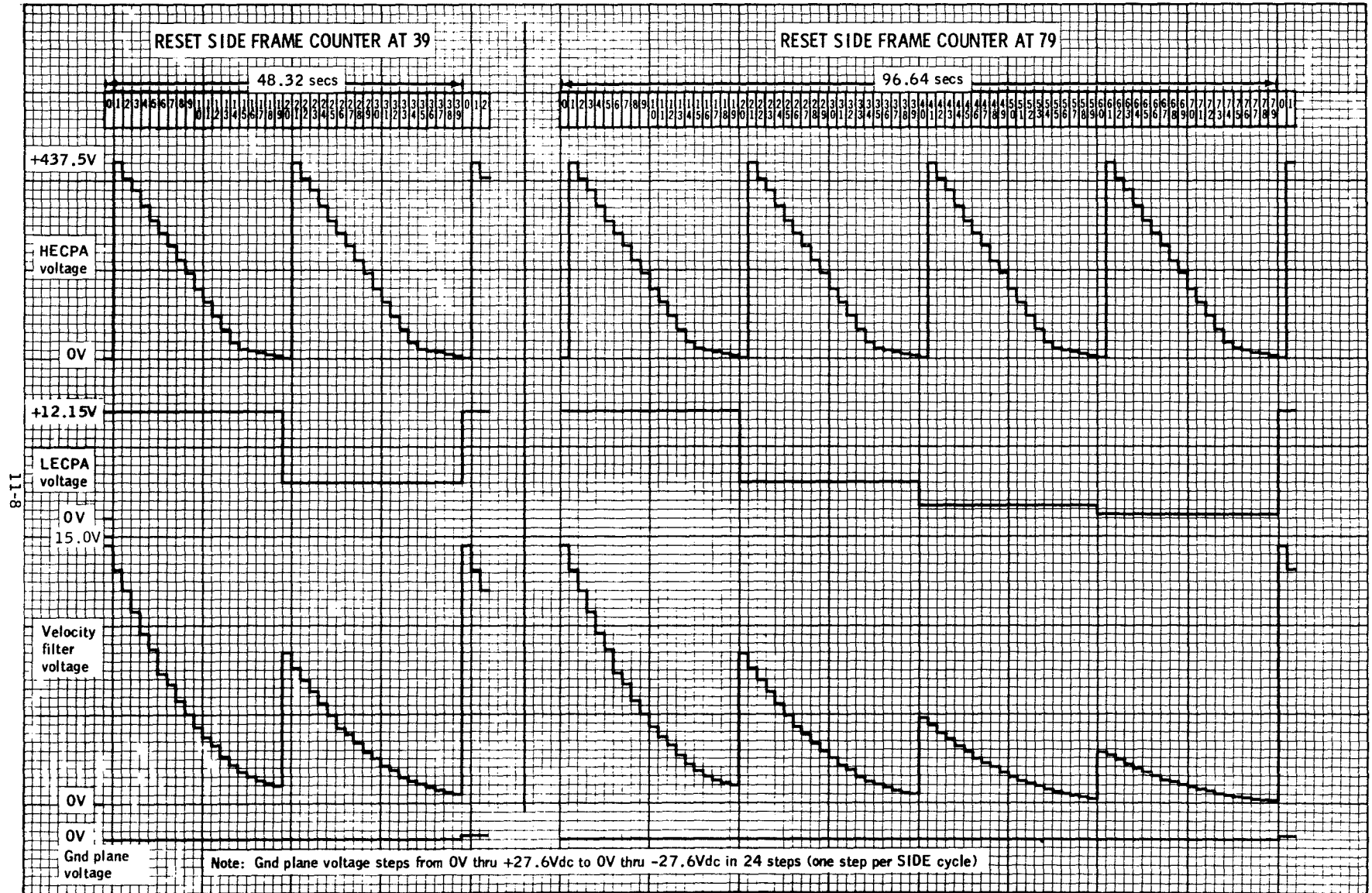

Figure 11-4. - Programed sensor voltage variations (reset at 39 and 79).

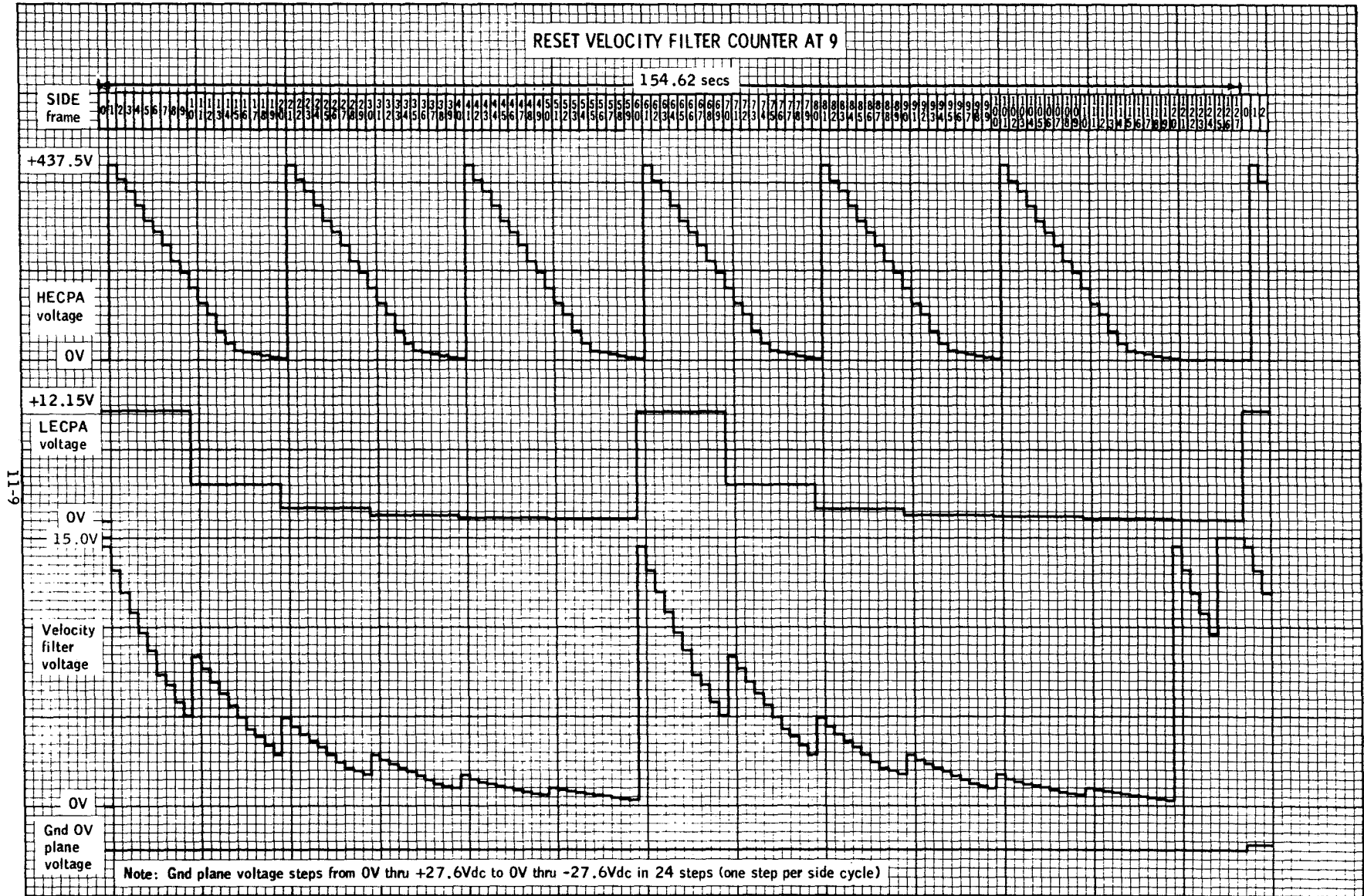
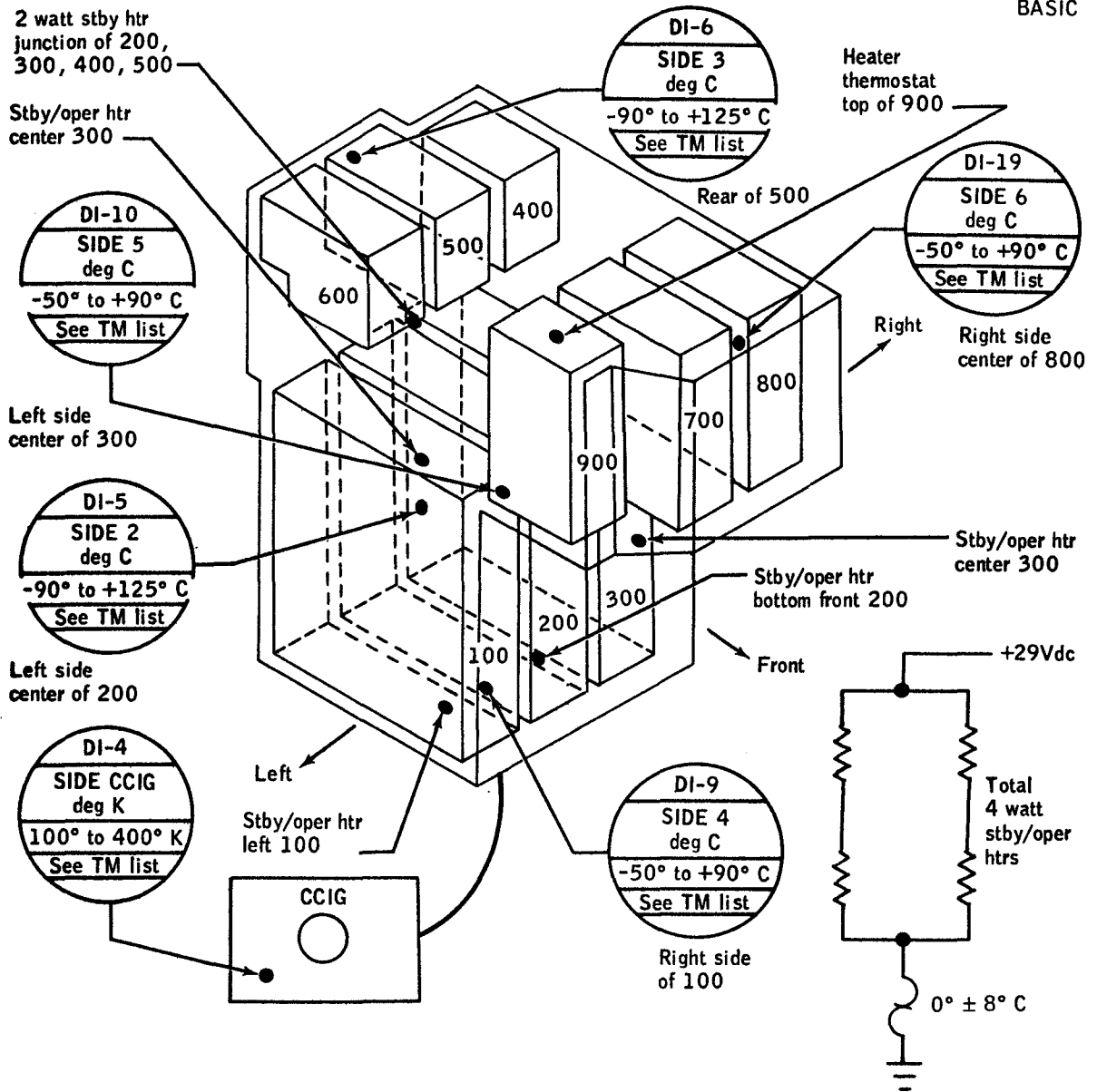
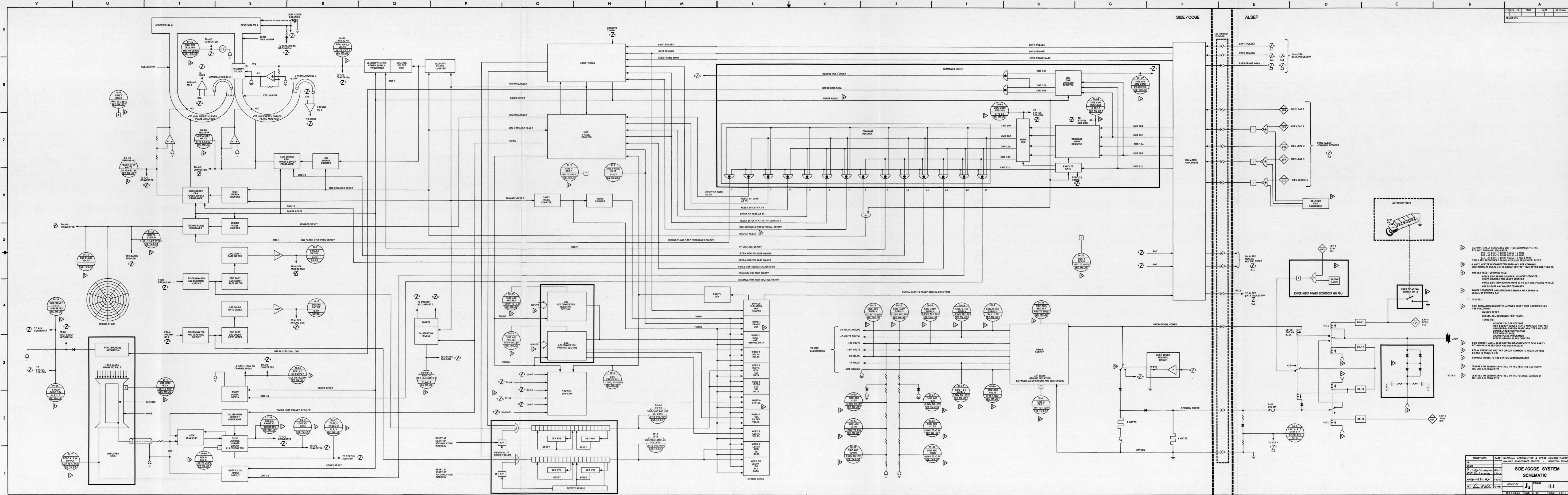

Figure 11-5. - Programed sensor voltage variations (reset at 9).



Temp 4	DI-9	Blivet 100	Logic timing, command system, strobe gates, SIDE frame counter, accumulators
Temp 2	DI-5	Blivet 200	A/D converters, ALSEP/SIDE interface networks, logic timing, subcommutators, CCGE cal command generator, dust cover removal circuit, cal dividers
Temp 5	DI-10	Blivet 300	Step voltage counters and generators, cal pulse generator
Temp 3	DI-6	Blivets 400/500	Low voltage power supply
		Blivet 600	Cal shapers, deadtime circuits, log count rate meters, -3.5 kV regulator
		Blivet 700	-3.5 kV converter and multiplier, 4.5 kV multiplier and output divider
Temp 6	DI-19	Blivet 800	Electrometer for CCGE
		Blivet 900	4.5 kV regulator and converter, electrometer range relay drivers and power supply, CCGE seal break circuit

Figure 11-6. - SIDE temp sensors, heater, and thermostat locations.



- AUTOMATICALLY GENERATED ONE-TIME COMMANDS VIA THE DELAYED COMMAND SEQUENCER:  
 105 - AT EIGHTH 10 HR PULSE +2 MINS  
 107 - AT EIGHTH 10 HR PULSE +4 MINS  
 110 - AT EIGHTH 10 HR PULSE +3 AND 5 MINS  
 TIMES ARE REFERENCED TO DELAYED CMD SEQUENCER RESET  
 4 WATT HEATER DISCONNECTED WHEN ANY SIDE COMMAND CONTAINS AN INITIAL 107 IN EXECUTED FIRST TIME AFTER SIDE TURN ON  
 MASTER RESET COMMAND WILL:  
 RESET SIDE FRAME COUNTER, VELOCITY COUNTER, HECPA COUNTER AND LECPA COUNTER  
 FORCE SIDE INTO NORMAL MODE TO 127 SIDE FRAMES / CYCLE  
 NET DUST COVER ON/OFF COMMANDS  
 POWER SEQUENCER AND ASTRO SWITCH NO 3 SHOWN IN DETAIL ON DRAWING 4.2  
 7. DELETED  
 SIDE ACTIVATION GENERATES A POWER RESET THAT ACCOMPLISHES THE FOLLOWING:  
 MASTER RESET  
 RESETS ALL COMMANDS FLIP-FLOPS  
 VELOCITY FILTER VOLTAGE  
 HIGH ENERGY CURVED PLATE ANALYZER VOLTAGE  
 LOW ENERGY CURVED PLATE ANALYZER VOLTAGE  
 CHANNELER HIGH VOLTAGE  
 COG HIGH VOLTAGE  
 GROUND PLANE PROGRAMMER  
 RESETS GROUND PLANE COUNTER  
 SIDE WORDS 1 AND 6 ALSO CONTAIN MEASUREMENTS OF 7-PARTY NET DUST COVER AND GND STEP  
 RELAY OPERATING VOLTAGE CIRCUIT COMMANDS TO RELAY DRIVERS LISTED IN TABLE 4-10B  
 DENOTES INPUTS TO THE STATUS SUB-COMMAND  
 DENOTES 7-W SENORS INPUTTED TO THE NEGATIVE SECTION OF THE LOG A/D CONVERTER  
 DENOTES 7-W SENORS INPUTTED TO THE POSITIVE SECTION OF THE LOG A/D CONVERTER

SIGNATURES		DATE	NATIONAL AERONAUTICS & SPACE ADMINISTRATION
DESIGN	DATE	11.1	MANAGED SPACECRAFT CENTER - HOUSTON, TEXAS
ENGINEER	DATE	11.1	
APP. BY	DATE	11.1	
REC	DATE	11.1	

SIDE/CCGE SYSTEM SCHEMATIC  
 11.1  
 11.1 X 30.25 PAGE 11.1 SHEET 1 OF 1

SECTION 12  
HEAT FLOW EXPERIMENT (S-037)

12.1 SYSTEM DESCRIPTION

12.1.1 Experiment Objectives

The heat flow experiment (HFE) measures the net outward flux of heat from the moon's interior. Measurement of lunar heat flux will provide:

- A. A comparison of the radioactive content of the moon's interior and the earth's mantle.
- B. A thermal history of the moon
- C. A lunar temperature-versus-depth profile
- D. The value of thermal parameters in the first three meters of the moon's crust.

When compared with seismic measurements, data from the HFE experiment will provide information on the composition and physical state of the moon's interior.

12.1.2 Major Components

The major components of the HFE are two sensor probes and an electronics package as shown in Figure 12-1.

12.1.2.1 Sensor probes.- The probes consist of epoxy-fiberglass tubular structures which support and house temperature sensors, heaters, and the associated electrical wiring. Each probe has two sections, each 55 cm (21.6 inches) long, spaced 2 cm (0.8 inches) apart and mechanically connected by a flexible spring. The flexible spring allows the probe assembly to be bent into a U-shape to facilitate packing, stowage, and carry.

There is a gradient heat sensor surrounded by a heater coil at each end of each probe section. Each of these two gradient sensors consists of two resistance elements. These four resistance elements are connected in an electrical bridge circuit. Ring sensors are located 10 cm (4 inches) from each end of each probe section. Each of these two ring sensors has two resistance elements. These four resistance elements are connected into an electrical bridge circuit. Also, four thermocouples are located in the cable of each probe, identified and spaced as follows: number one at the upper end of the probe, numbers two, three and four spaced 25, 45, and 65 inches up the cable from the end of the probe.

12.1.2.2 Electronics package.- The heat flow electronics package contains six printed circuit boards which mount the functional circuits of the experiment. An external cable reel houses the HFE/central station cable and facilitates deployment. A sunshield thermally protects the electronics package from externally generated heat. Two reflectors built into the open ends of this sunshield aid in the radiation of internally generated heat that otherwise might be entrapped under the sunshield. The electronics package is thermally protected by multilayer insulation and thermal control paint.

12.1.3 Deployment

The HFE is deployed with the two sensor probes implanted in the lunar surface in 3-meter (10-foot) boreholes. These holes are drilled by the astronaut with the Apollo lunar surface drill (ALSD). (Refer to Section 13 for a description of ALS D.) The two probes are connected by two multiple-lead cables to the HFE electronics package which is deployed separately from the ALSEP central station.

12.2 HFE MODES

The HFE performs its measurements in three basic modes of operation: Mode 1 or Mode/G, Mode 2 or Mode/LK, and Mode 3 or Mode/HK.

12.2.1 Mode/G, Normal Gradient Mode

The normal gradient mode is used to monitor the heat flow in and out of the lunar surface crust. Heat from solar radiation flows into the moon during the lunar day and out of the moon during lunar night. This larger heat gradient in the near subsurface of the moon will be monitored and measured in order to differentiate it from the more steady but smaller heat flow outward from the interior of the moon.

12.2.2 Mode/LK, Low Conductivity, and Mode/HK, High Conductivity

Thermal conductivity of the lunar material is measured with the principle of creating a known quantity of heat at a known location by exciting one of the eight probe heaters, and measuring the resultant probe ambient temperature and temperature differentials for a period of time. Because it is not known whether the surrounding material will have a low conductivity (loosely consolidated material) or a high conductivity (solid rock), the capability to measure over a wide range using two modes of operation is incorporated into the HFE design.

12.2.3 Ambient Temperature Measurements

Ambient temperature measurements are made at any gradient bridge or at any one of the thermocouples spaced at four points along each probe cable. In each probe cable, the thermocouples are placed at the top gradient sensor and at distance increments of 25, 45, and 65 inches above the top gradient sensor. The reference junction for the thermocouples is mounted on the HFE electronics package thermal plate.

12.2.3.1 Mode/G.- Normal (gradient) mode initiated by octal command 135 (gradient sensor excitation - no heater excitation). The heat gradients (temperature differentials) and probe ambient temperatures are measured with the gradient sensors and the thermocouples spaced along the two cables connecting the probes to the electronics package. In each deployed probe, the temperature difference between the ends of each of the two sections is measured by the gradient bridge consisting of the gradient sensors positioned at the ends of the probe section. Gradient temperature differentials are measured in both the high sensitivity and low sensitivity ranges.

12.2.3.2 Mode/LK.- Low conductivity mode (ring source) initiated by octal command 136 (gradient sensor excitation - low heater excitation). The probe heater selected by octal command 152 receives low power excitation and dissipates 2 milliwatts of power. The thermal conductivity is determined by measuring the temperature rise of the gradient bridge around which the selected heater is located. The temperature which the heater must reach to dissipate the power input is the measure of thermal conductivity of the surrounding material. The low conductivity measurements are performed in the sequence selected by earth command.

12.2.3.3 Mode/HK.- High conductivity mode (heat pulse) initiated by octal command 140 (ring sensor excitation - high heater excitation). The probe heater selected by octal command 152 receives high power excitation and dissipates 500 milliwatts of power. The thermal conductivity is determined by measuring the temperature rise at the ring bridge nearest the selected heater. The temperature rise per unit of time at the known distance is the measure of thermal conductivity of the surrounding material. The high conductivity measurements are heat gradients in the high sensitivity range and probe ambient temperatures. The bridge used in performing a measurement is determined by the heater selected.

TABLE 12-I. - HFE MEASUREMENT OPTIONS (MODES 1 AND 2)

Location/Name	Symbol	Cmds and Order (Octal)															
		135*	135*	135*	135*	135*	135*	135*	135*	135*	135*	135*	135*	135*	135*	135*	135*
		141						142	142	142	142	142	143	143	143	143	
		-	144	144	-	144	-	144	144	-	144	-	144	144	-	144	
		-	-	145	145	-	-	-	145	145	-	-	-	145	145	-	
		-	-	-	146	146	-	-	-	146	146	-	-	-	146	146	
Temp grad high sens	DH-01																
Temp grad high sens	DH-02																
Temp grad high sens	DH-03																
Temp grad high sens	DH-04																
Temp grad low sens	DH-05																
Temp grad low sens	DH-06																
Temp grad low sens	DH-07																
Temp grad low sens	DH-08																
Probe ambient temp	DH-09																
Probe ambient temp	DH-10																
Probe ambient temp	DH-11																
Probe ambient temp	DH-12																
Temp ref junction	**DH-13																
Probe cable temp (1)	***DH-14, 24, 34, 44																
Temp ref junction	**DH-15																
Probe cable temp (2)	***DH-16, 26, 36, 46																

12-3

\*\*\* Thermocouple group measurement  
 \*\* DH-13 and DH-15 are identical physical measurements separated in time by approximately 54 seconds  
 \* Command 135 selects Mode 1, Command 136 selects Mode 2

TC <sub>1</sub> Group		R-Bits		TC <sub>2</sub> Group	
Symbol	Data	R <sub>2</sub>	R <sub>1</sub>	Symbol	Data
DH-14	Ref TC-TC <sub>1</sub> (4)	0	0	DH-16	Ref TC-TC <sub>2</sub>
DH-24	TC <sub>1</sub> (4) - TC <sub>1</sub> (1)	0	1	DH-26	TC <sub>2</sub> - TC <sub>2</sub> (1)
DH-34	TC <sub>1</sub> (4) - TC <sub>1</sub> (2)	1	0	DH-36	TC <sub>2</sub> - TC <sub>2</sub> (2)
DH-44	TC <sub>1</sub> (4) - TC <sub>1</sub> (3)	1	1	DH-46	TC <sub>2</sub> - TC <sub>2</sub> (3)

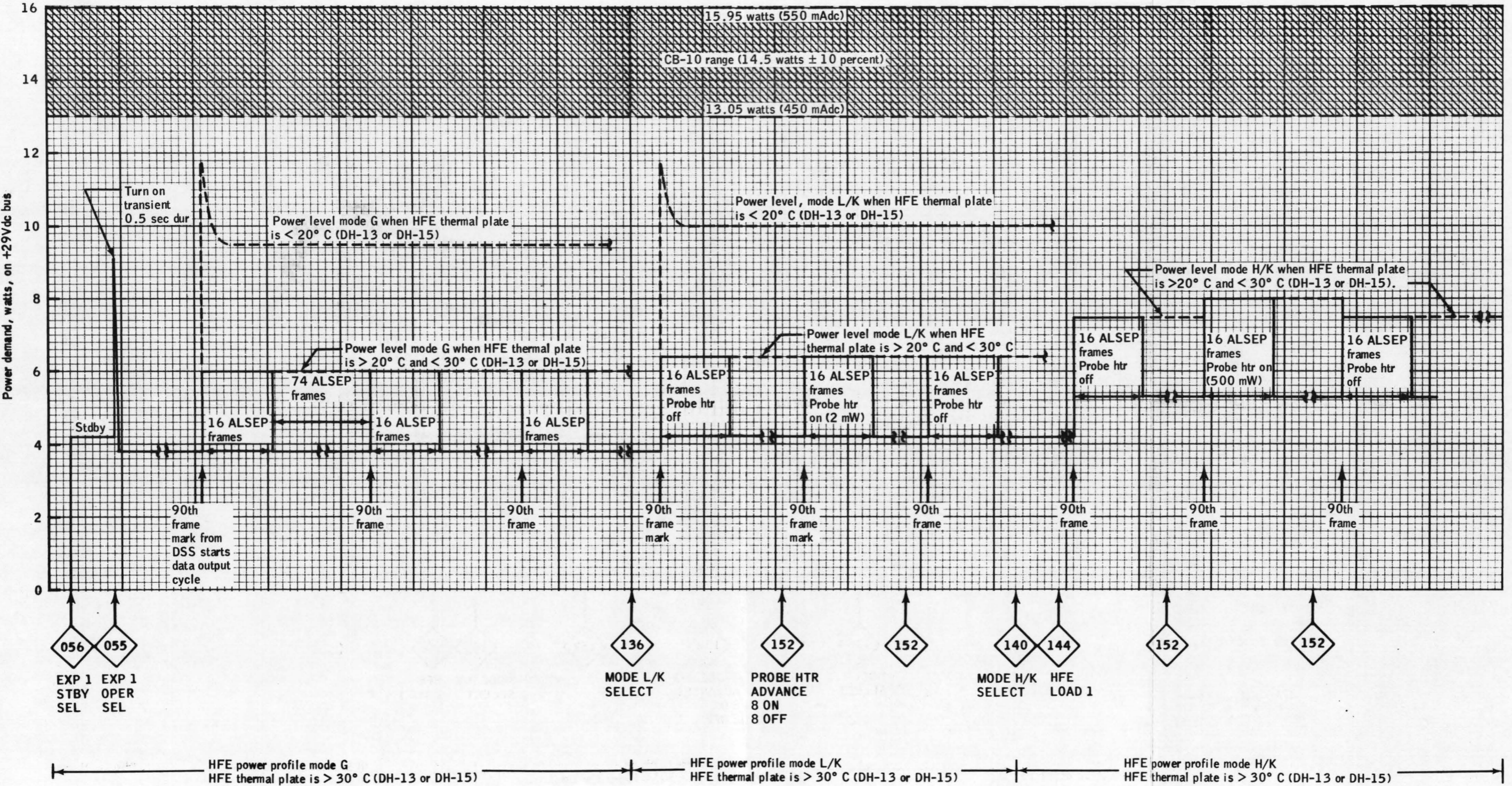

Figure 12-1. - HFE power profile.



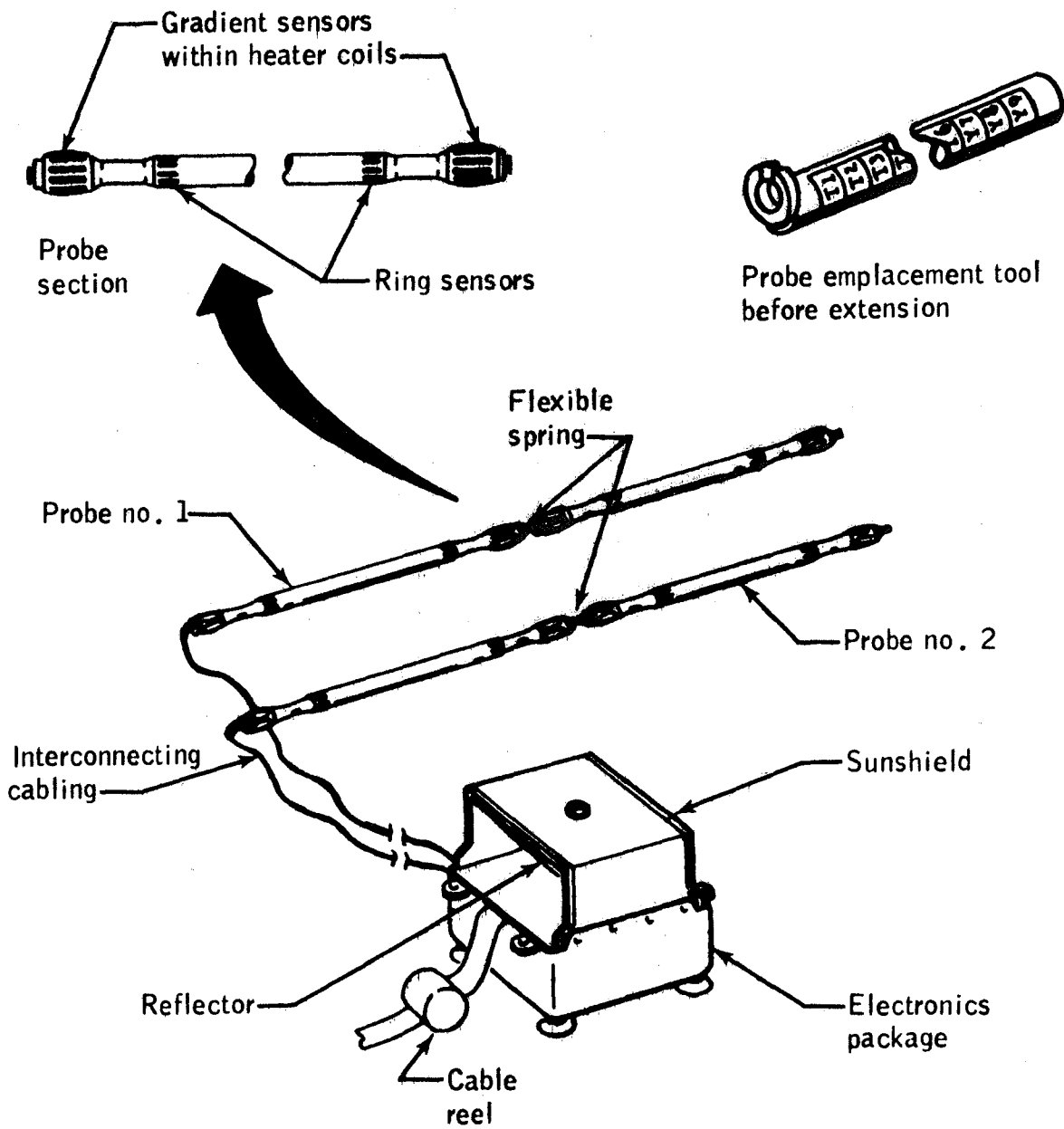

Figure 12-2. - Heat flow experiment.  
12-5

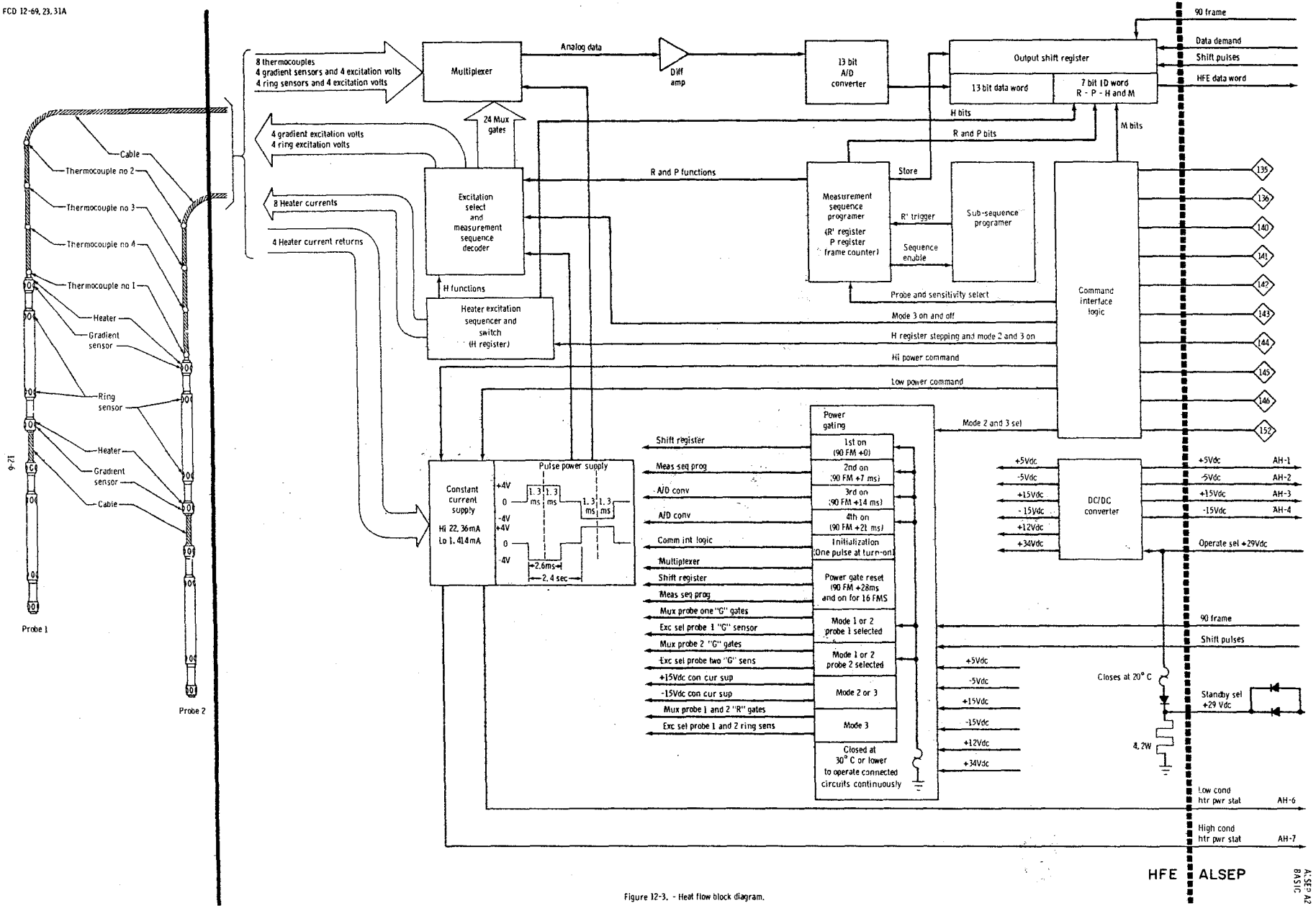

Figure 12-3. - Heat flow block diagram.

HFE ALSEP

ALSEP A2  
BRASIC

FCD 11-69.23.15A

Measurement sequences for one section of one probe  
 $\Delta TH$  (modes 1 and 2)

1. Meas 1 + pulse P/S
2. Meas 2 + pulse P/S
3. Meas 1 - pulse P/S
4. Meas 2 - pulse P/S

$\Delta TL$  (modes 1 and 2)

1. Meas 3 + pulse P/S
2. Meas 2 + pulse P/S
3. Meas 3 - pulse P/S
4. Meas 2 - pulse P/S

12-7

Differential temp (mode 3)

1. Meas 4 + pulse P/S
2. Meas 5 + pulse P/S
3. Meas 4 - pulse P/S
4. Meas 5 - pulse P/S

Ambient temp (mode 3)

1. Meas 4 + pulse P/S
2. Meas 6 + pulse P/S
3. Meas 4 - pulse P/S
4. Meas 6 - pulse P/S

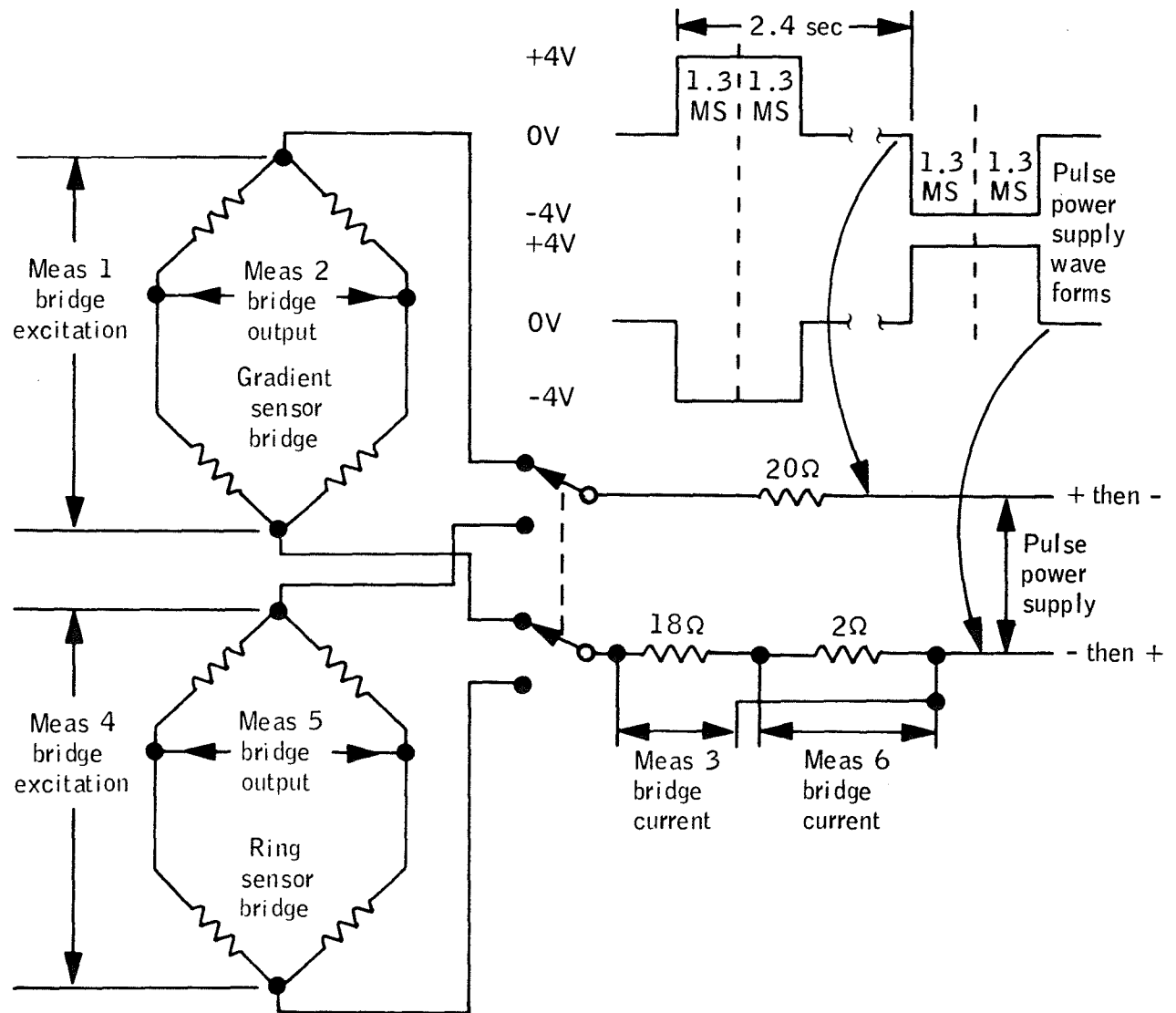
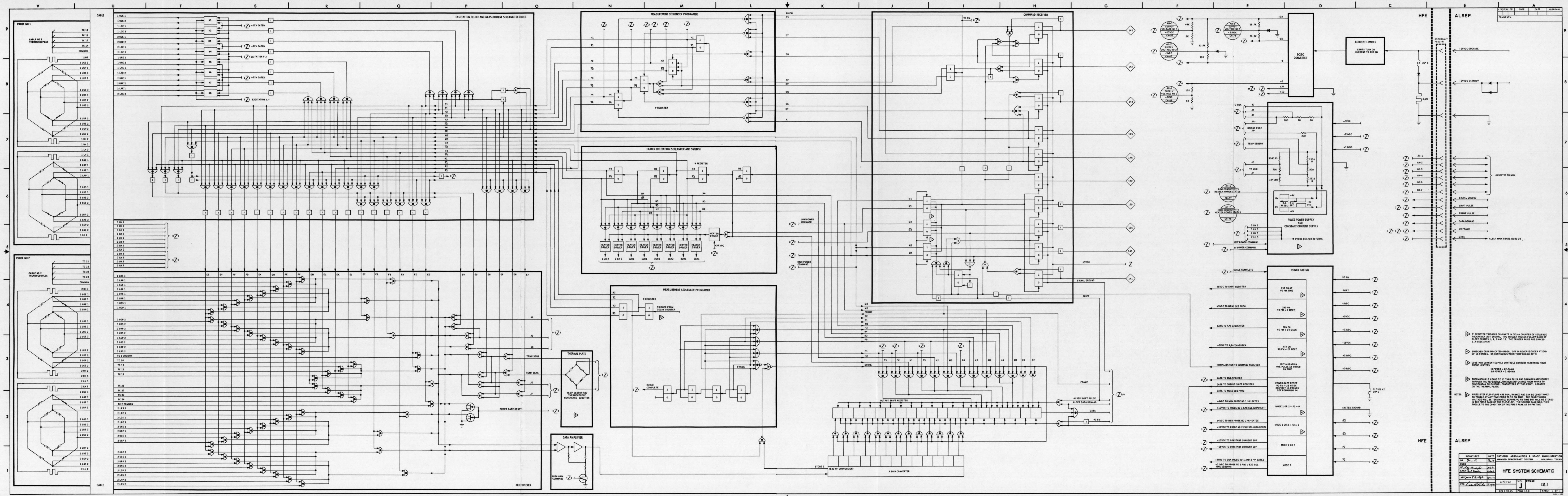

Figure 12-4. - Heat flow probe measurement sequences.



DATE	ENGR	APPROVAL
12/11/60	J. J. ...	...

- ⚠ REGISTER TRIGGER PULSES ORIGINATE IN DELAY COUNTER OF SEQUENCE PROGRAMMER AND TRIGGER TWO TRIGGER PULSES FOR EACH OF ALSEP FRAMES 1, 4, 8 AND 12. THE TRIGGER PULSES ARE SPACED 1.3 MSEC APART.
- ⚠ SWITCHED ON IN INDICATED ORDER. OFF IN REVERSE ORDER AT END OF 16 FRAMES. ON CONTINUOUS WHEN TEMP BELOW 30°C.
- ⚠ CONSTANT CURRENT SUPPLY CONTROLS CURRENT RETURNING FROM PROBE HEATERS.  
HP POWER = 22.30MA  
LP POWER = 1.45MA
- ⚠ THERMOCOUPLE LEADS TC 11 THRU TC 24 AND COMMONS ARE ROUTED THROUGH THE REFERENCE JUNCTION AND CHANGE FROM BOM TO ON THE THERMAL PLATE.

NOTES:  
 ⚠ REGISTER FLIP-FLOPS ARE DUAL RANKED AND CAN BE CONDITIONED TO TUGGLE AT ANY TIME PRIOR TO 90 FM TIME. THE CONDITIONING VOLTAGE WILL BE TERMINATED BEFORE 90 FM TIME BUT WILL BE STAYED IN THE FIRST BANK OF THE FLIP-FLOP. THE SECOND BANK WILL THEN TUGGLE TO THE CONDITION OF THE FIRST BANK AT 90 FM TIME.

SIGNATURES	DATE	NATIONAL AERONAUTICS & SPACE ADMINISTRATION
...	...	...

**HFE SYSTEM SCHEMATIC**

REV	DATE	BY	CHKD	APP'D	DESCRIPTION
1	12/11/60	J. J. ...	...	...	...

SECTION 13  
APOLLO LUNAR SURFACE DRILL

13.1 SYSTEM DESCRIPTION

13.1.1 Objectives

The Apollo lunar surface drill (ALSD) is used to provide a means for an astronaut to implant heat flow temperature probes below the lunar surface and to collect subsurface core material.

13.1.2 Drilling Principle

The drilling device which will be employed to produce the lunar subsurface holes is a hand-held, battery-powered, rotary-percussion drill. The rotary-percussion drilling principle was selected for this application for the following reasons:

- A. The axial bit pressure and rotary torque requirements for efficient drilling are considerably less than that required for rotary drilling.
- B. The drill bit operating temperatures are sufficiently low to preclude the requirement for a drill bit coolant such as air or water.
- C. The tungsten-carbide bit cutters will drill with reasonable efficiency in the presence of a small dust layer in the bottom of the hole, a factor which is inherent with a mechanical cuttings transport system.

13.1.3 Operational Parameters

The ALSD is inherently capable of core drilling a 1.032-inch diameter hole in dense basalt (22,000 psi compressive strength) at a maximum rate of 2.5 inches per minute, or 43% porosity vesicular basalt at a maximum rate of 6 to 8 inches per minute, with an optimum applied axial bit pressure of 60 pounds. Under actual lunar surface drilling conditions, the maximum drilling penetration rate is degraded in proportion to the hole depth and available axial bit pressure which can be manually applied by the astronaut. Penetration rates in conglomerate or pumice type materials vary from 30 to 120 inches per minute.

13.1.4 Drilling Operation

Implanting the temperature probes requires drilling two holes to a maximum depth of 3 meters. The holes are cased to prevent cave-in and to facilitate insertion of the probes. The drilling and casing operations are combined via use of epoxied, wound boron filament casing tubes. The first tube of the six in each string assembly incorporates a drill bit. The core sampling tubes (six per string) are 0.752 inches in diameter and are extruded titanium. The core sampling operation takes second priority to the HFE casing operation.

13.1.5 Deployment

The ALSD is designed as a totally integrated system which interfaces with the ALSEP pallet located in the LM during transit from earth to the moon's surface. The drill and associated assemblies can be removed as a single package from the ALSEP pallet and transported by the astronaut to the selected drilling site for subsequent assembly and operation. (See Figure 13-1.)

Note: Both handgrips must be pushed in to operate motor

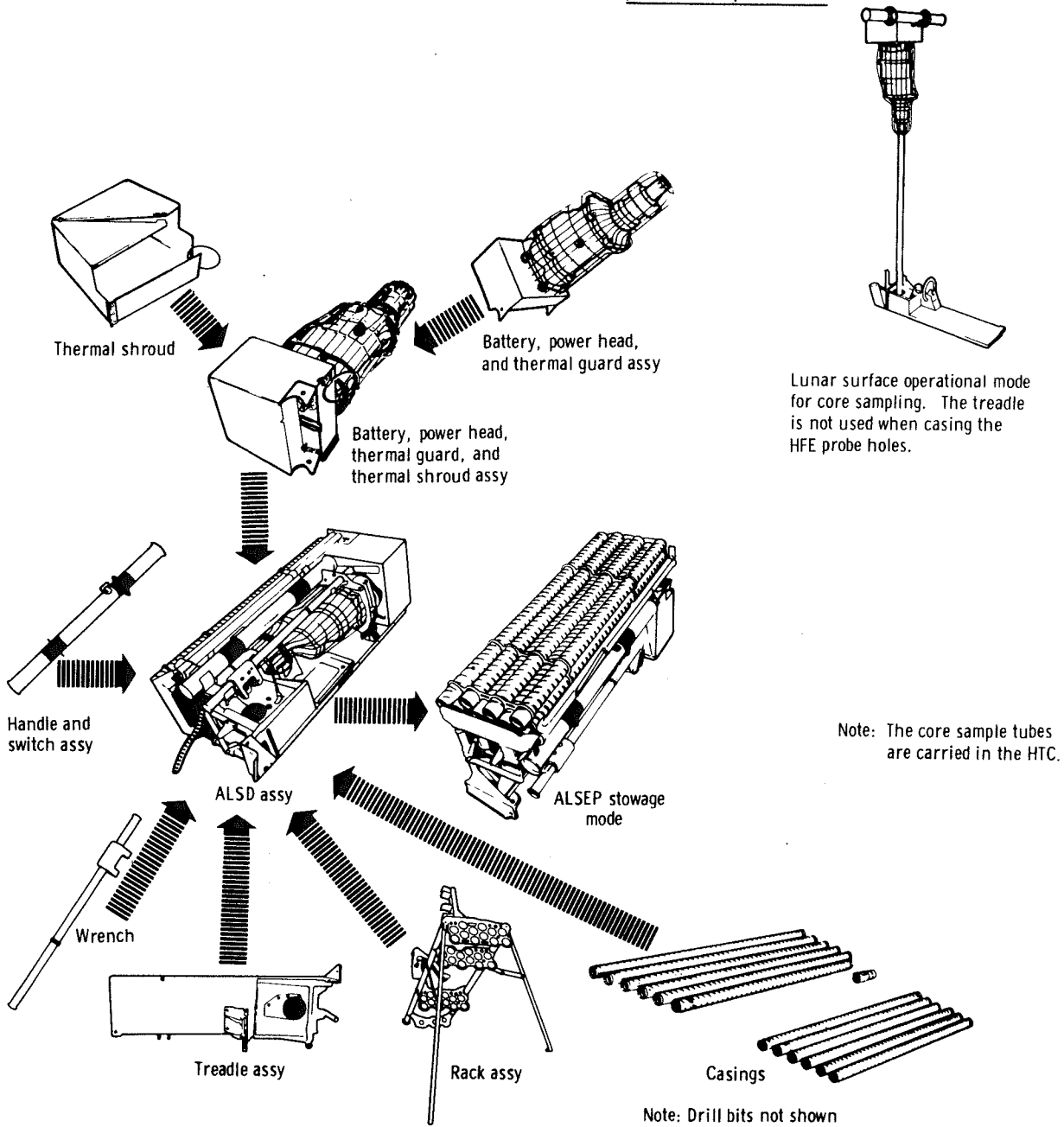

Figure 13-1. - ALSD assembly, stowage, and lunar operating sequence.

13.2 ALSD PHYSICAL DESCRIPTION

13.2.1 Major Elements

The ALSD is a hand-held battery-powered, rotary percussion drill consisting of four major elements: a battery pack, power head, drill string, and accessory group (Figure 13-1). Table 13-I provides leading particulars of the Apollo lunar surface drill.

13.2.2 Battery Pack

The battery pack provides the power necessary for the lunar surface drilling mission. The battery pack comprises a battery case, battery cells, power switch, thermal shroud, and handle assembly.

13.2.2.1 Battery case.- The battery case is a magnesium alloy enclosure with a pressure relief valve, electrical receptacle, and power switch. Integral with the case are brackets for securing the case to the power head and the portable handle assembly. The external surface of the case is coated for a high ratio of thermal emissivity-to-absorptivity to control the battery temperature profile during lunar surface operation. The case material shields the active circuit elements and conductors to contain potential electromagnetic interference.

13.2.2.2 Battery cells.- The battery has 16 individual cells and operates at a nominal output of  $23 \pm 1$  volts dc at 18.75 amperes for 40 minutes. Each cell is constructed with a silver oxide primary and zinc secondary encased in a high temperature plastic. The battery cells are activated by filling each cell with a dry electrolyte of KOH during the prelaunch operations.

13.2.2.3 Power switch.- The power switch is a single-pole, single-throw, heavy-duty microswitch with a push-to-activate mechanism. Both handles must be pushed toward the centerline of the drill motor simultaneously for the motor to operate. The switch portion of the assembly is contained by the battery case with the push-to-activate mechanism protruding through the case for external operation.

13.2.2.4 Thermal shroud.- The thermal shroud, fabricated predominately from aluminum alloy sheeting, provides battery temperature compensation during temporary lunar stowage under the combined effects of minimum temperature (20 degrees F) and low sun angles (7 to 22 degrees) above the lunar horizon. The shroud will be removed from the ALSD at sun angles higher than 22 degrees above the horizon. Under all sun angle conditions, the shroud will be removed when the ALSD is used to perform the drilling mission. Removal is performed by pulling a release lanyard. The thermal shroud will always be installed on the battery case during the trans-lunar portion of the mission and at specified sun angles when the ALSD is undergoing temporary lunar stowage.

13.2.2.5 Handle assembly.- The handle assembly provides the astronaut with a means of manual restraint and ALSD motor control. The handle assembly comprises the handle and the switch actuator assembly. The handle enables the astronaut to provide the rotary restraint and axial force required for drilling. The switch actuator assembly contains the fail-safe controls for operating the power head motor. The handle assembly is attached to the battery case by fixed and spring-loaded lock pins.

13.2.3 Power Head

The power head is self-contained within a housing which interfaces with the battery and drill string. The power head comprises a housing, motor armature, power train, clutch assembly, percussor, shock absorber, output spindle, pressurization system, and a thermal guard shield.

13.2.3.1 Housing.- The housing consists predominantly of three magnesium alloy castings mated together by externally sealed flanges threaded for socket head screws. The internal surfaces of the castings are impregnated with a polyester resin sealant to prevent leakage through the walls.

13.2.3.2 Motor armature. The motor armature is a nominal 0.4 horsepower, brush-commutated, direct-current device employing as its field a permanent magnet. The armature is wound with copper wire protected by high

temperature insulation. The motor possesses a peak efficiency of approximately 70% when operating at its nominal 9,300 rpm at an input voltage and current of 23 volts dc and 18.75 amperes, respectively. A reduction gear couples the output shaft of the motor armature to the power train.

- 13.2.3.3 Power train.- The power train consists of reduction gears which provide the proper rotational speeds for the percussor cam gear and output drive spindle of 2270 blows per minute and 280 revolutions per minute, respectively.
- 13.2.3.4 Clutch assembly.- The clutch assembly consists of a metal disc emplaced between two bronze discs. Friction between the discs is maintained by a preloaded spring. The clutch assembly is in series with the power train behind the final output drive gear. The clutch assembly limits the reactive torque load to a level which can be safely controlled by the astronaut.
- 13.2.3.5 Percussor.- The percussor converts the uniform rotary output motion of the power train into pulsating, high energy, short duration, linear impact blows which are delivered to the output spindle. This action is accomplished by a rotating cam riding against a spring-loaded cam follower which is an integral part of the percussor.
- 13.2.3.6 Shock absorber.- The shock absorber consists of a telescoping, titanium tube element (internal to and concentric with the percussor spring) restrained by the center housing. When the end of the shock absorber is impacted by the percussor hammer, the titanium tube or boron filament tube elements extend under tension thus dissipating the percussor energy into heat.
- 13.2.3.7 Output spindle.- The output spindle contains a female double lead thread, one revolution per inch pitch, which mates interchangeably with any titanium core sample extension tube and the hole casing adapter. Visual rotation indicators are painted on the output spindle to serve as a positive means of determining drill string rotation.
- 13.2.3.8 Pressurization system.- The pressurization system maintains pressure integrity within the power head housing through the use of eight static seals, one linear bellows dynamic seal, and two rotary dynamic seals. The static seals are employed between the three housing sections, front end section, and the various components such as the connector, pressure relief valve, and lubrication ports. The lubricated dynamic seals are employed with the output spindle. Internal pressure of the power head is controlled by a 10 (+ 1) psi relief valve.
- 13.2.3.9 Thermal guard shield.- The thermal guard shield consists of a wire cage mounted to the external surface of the power head. The shield is used to prevent damage to the astronaut's suit when accidentally brushing against the power head which may have a temperature exceeding +250° F.
- 13.2.4 Hole Casing  
The epoxied boron filament hole casing provides the cutting capability required for boring the hole in any lunar surface material which may be encountered ranging in hardness from dense basalt to unconsolidated conglomerate. The drill string is comprised of one boron filament tube with a steel drill bit bonded to its lower end and five extension tubes. All are approximately 22 inches in length.
- 13.2.4.1 Core bit.- The core bit is composed of five tungsten-carbide tips which are brazed into a steel body and functions to provide the rock cutting capability of the titanium core sample string. For helical flutes are machined into the outer diameter of the bit body. The flutes, or ramps, transport the rock cuttings from the face of the cutting tips upward to the double flute system of the extension tubes and subsequently to the surface. Coupling of the core bit to the extension tubes is accomplished by double acme-type male threads machined into the titanium extension tubes and core bit.



- 13.2.4.2 Extension tubes.- The six titanium extension tubes provide the mechanical coupling to transmit the rotary-percussive energy from the power head output spindle to the core bit. During normal casing or core sampling operations, the extension tubes are added in groups of two, (either boron filament casing tubes or titanium core sampling tubes), as the depth of the hole increases until the full depth of the three meters is attained.
- 13.2.5 ALSD Accessory Group  
The accessory group comprises extension tube caps, boron filament, hole casings, hole casing adapter, rack assembly, treadle assembly, and a wrench.
- 13.2.5.1 Core sampling extension tube caps.- The core sampling extension tube caps are fabricated from teflon and are installed on each end of the extension tubes after completion of core sample drilling. The caps prevent loss of core material from within the extensions during stowage in the sample return container (SRC) for the earth return flight.
- 13.2.5.2 Boron filament hole casings.- Hole casings are employed by the astronaut on the lunar surface when the hole is drilled in unconsolidated material which might cave in. Twelve hole casing sections are required for the two 3-meter holes. The casings are fabricated from continuous boron filament, epoxy laminated tubes. The casings are assembled in groups of two and power drilled into the surface with the power head. The first casing of each assembly incorporates a closed steel drill bit tip on its forward end which prevents entry of core material during the emplacement process. The continuous 0.875 inch inside diameter of the emplaced hole casing permits rapid insertion of the HFE probe.
- 13.2.5.3 Hole casing adapter.- The hole casing adapter, made of titanium with one end that mates with the hole casings and the other end mating with the power head, is used to sequentially couple the double sections to the power head during the casing emplacement process.
- 13.2.5.4 Rack assembly.- The rack assembly is made of magnesium alloy and provides basic restraint for the twelve hole casings, wrench, and handle assembly within the ALSD assembly stowage mode during the outbound translunar phase of the mission. On the lunar surface, the rack is deployed into a tripod configuration which provides vertical stowage for the core bit, core sampling tubes, and hole casings.
- 13.2.5.5 Treadle assembly.- The treadle assembly is primarily aluminum alloy sheeting and provides structural restraint for the rack assembly and battery power head assembly during outbound mission stowage on the ALSEP subpackage. On the lunar surface, the treadle assembly drill string locking feature is used in conjunction with the wrench for uncoupling core sampling extension tube joints during phases of the core sampling operation.
- 13.2.5.6 Wrench.- The wrench is a multi-purpose tool employed to perform four functions:
- A. To decouple emplaced extension tubes in conjunction with the treadle assembly.
  - B. To aid in retracting the emplaced core sample string after completion of core sampling.
  - C. To aid in retrieving objects from surface level (e.g., extension tubes, treadle assembly).

TABLE 13-I.- ALSD LEADING PARTICULARS

Characteristic	Value
<u>Battery Assembly</u>	
Silver-zinc cells	16 cells
Open circuit voltage	29.6 ± 0.5 Vdc
Operating voltage	23.0 ± 1 Vdc
Nominal operating current	18.75 amperes
Nominal power capacity	300 watt-hours
Activated storage life	30 days
Recharge capability	3 cycles
Dry storage life	2 years
Electrolyte (dry type)	40% potassium hydroxide
Cell pressure	8 ± 3 psig
ECS (case) pressure	5 ± 0.5 psig
Weight	7.24 pounds
<u>Power Head</u>	
Motor	
Operating voltage	23.0 ± 1 Vdc
Load speed	9300 rpm
Load current	18.75 amperes
Efficiency	70%
Percussor	
Blow rate	2270 bpm
Energy per blow	39 inch-pounds
Spring energy	240 pounds/inch
Effective hammer weight	0.661 pounds
Hammer velocity	213 inches/second
Power Train	
Motor-to-cam ratio	4.1
Motor-to-drive shaft ratio	33.1
Drive shaft speed	280 rpm
Blows per bit revolution	8.1
Weight	8.37 pounds
<u>Drill String Assembly</u>	
Integrated length	126 inches
Extension tube length (core sampling)	16.75 inches
Drill bit	
Cutting diameter	1.032 inch
Body outside diameter	1.00 inch
Body inside diameter	0.802 inch
Length	2.5 inches
Number of carbide cutters	5
Inside cutting (core) diameter	0.752 inch
Weight	3.49 pounds
<u>Hole Casing Sleeve (12)</u>	
Wall Thickness	0.025 inch
Length	22 inches
Nominal diameter	1.06 inch

13.3 ALSD FUNCTIONAL DESCRIPTION

13.3.1 Battery/Power Head Operation

13.3.1.1 Battery to power train.- Power is supplied from the 16-cell silver oxide-zinc battery to the power head motor (Figure 13-2) at 23 Vdc. The nominal speed of the motor armature is 9300 rpm. A reduction gear couples the output shaft of the motor to the power train which consists of the necessary reduction gears to provide the desired rotary motion and percussive action: 280 rpm at 2,270 blows per minute at the output shaft.

13.3.1.2 Power train to percussor.- The interface between the power train and the percussor is provided by the clutch. The clutch limits the torque load to a level which can be safely controlled by the astronaut. (The clutch is designed for a nominal slip value of 20 foot-pounds.)

13.3.1.3 Percussor to drill string.- The percussor converts the uniform rotary output motion of the power train into pulsating, high-energy, short-duration, linear-impact blows to the output shaft of the power head. The impact action is accomplished by a rotating cam against a cam follower which also serves as the hammer. As the cam rotates, the follower raises, cocking a spring. The spring, by virtue of the cam shape, releases its kinetic energy rapidly thereby accelerating the hammer toward a transition section. This transition section, or power head shaft, serves as the anvil for the hammer and as the receiver for the rotary motion output of the power train.

13.3.2 Drill String Operation

13.3.2.1 Drilling.- The rotary-percussive energy at the output of the power head is coupled to the core bit by the titanium core sampling string. The core sampling string operates through the treadle assembly which employs a locking mechanism insuring positive energy coupling to the core bit. The core bit delivers the rotary-percussive energy to the rock. The percussive element of the input energy fractures the rock by exceeding its compressive strength under each cutting tip. The rotary element of the input energy repositions the cutting tips for subsequent rock fracturing and provides the means for transporting the rock cuttings upward to the surface via the helical transport flutes. The above is also true for the hole casing string except that the extensions are boron filament tubes.

13.3.2.2 Core storage.- The core sample string stores the core material cuttings. After the hole is completed the core sample string is disassembled, capped, and installed into the sample return container (SRC) for eventual return to earth of lunar core material samples.

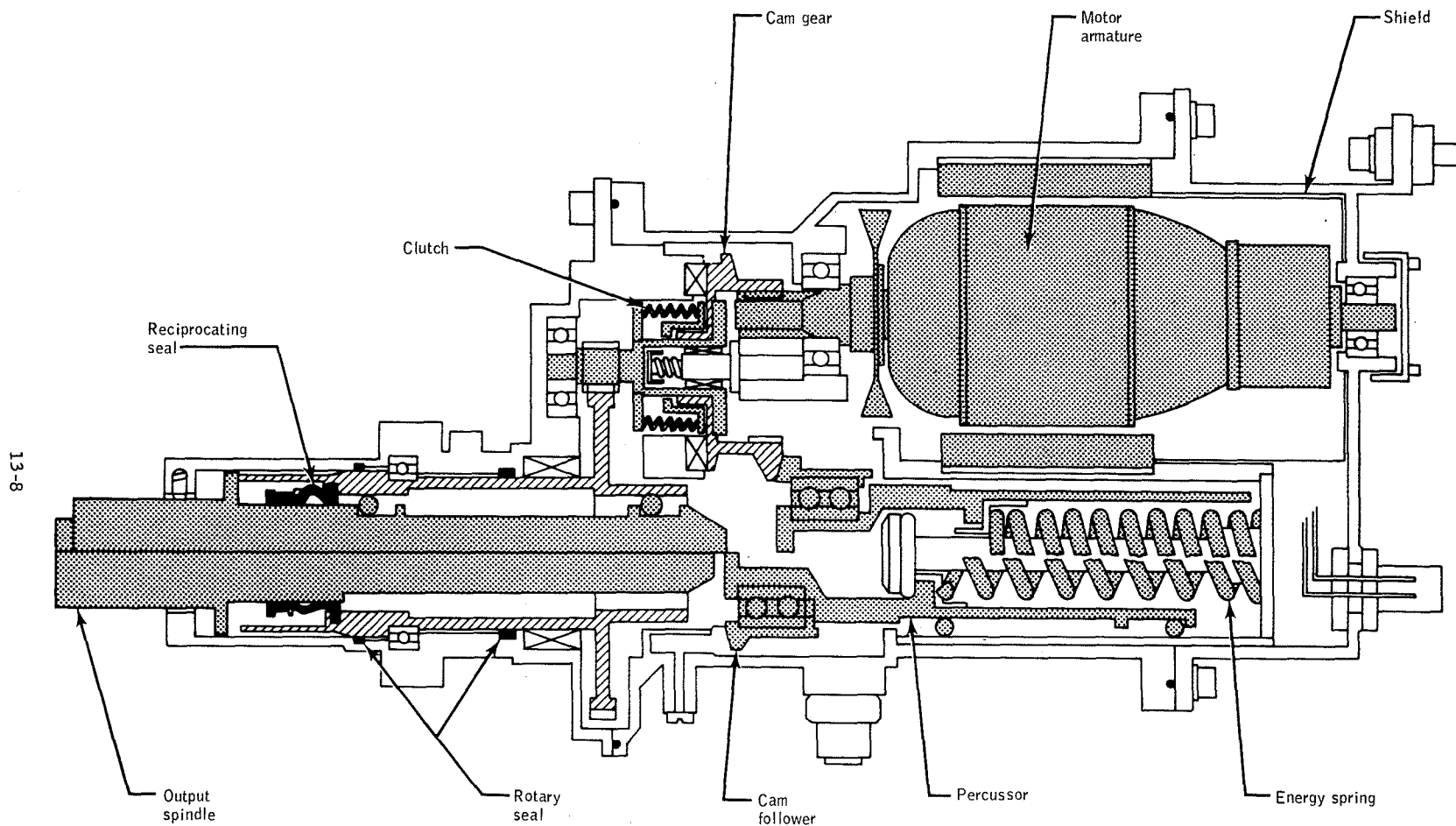

13-8

Note: Percussor and spindle shown in both fully retracted and fully extended positions.

Figure 13-2. - ALSD power head, simplified cutaway view.

NASA — MSC — Conit., Houston, Tex.

ALSEP A2  
BASIC

**APOLLO**

**ALSEPSH**

**APOLLO LUNAR  
SURFACE  
EXPERIMENTS  
PACKAGE  
SYSTEMS  
HANDBOOK**

**ALSEP A2**

**MARCH 24, 1971**



**FCD  
MSC  
NASA**