

FINAL REPORT
FOR
ALSEP ARRAYS A, B, C, AND A-2
BSR 4096
September 1973

REVISIONS

LTR.	DATE	PAGE	DESCRIPTION

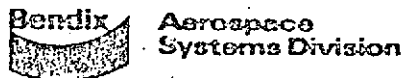

TYPE	<input type="checkbox"/> PRELIMINARY	<input checked="" type="checkbox"/> FINAL
------	--------------------------------------	---



BENDIX DOCUMENT: BSR 4096 DATE: September 1973	TITLE Final Report for ALSEP Arrays A, B, C and A-2
--	---

DELIVERY REQMT. Article IV, Item 70	CONTRACT NAS 9-5829 Schedule I
---	--------------------------------------

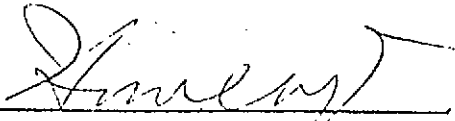
APPROVALS

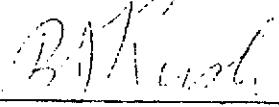
NASA  _____ COGNIZANT MANAGER  _____ PROGRAM MANAGER	BENDIX  _____ COGNIZANT MANAGER  _____ PROGRAM DIRECTOR
--	--

CONTENTS

	<u>Page</u>
1. INTRODUCTION	1-1
2. ALSEP DESCRIPTION	2-1
2.1 ALSEP FLIGHT SYSTEM DESCRIPTION	2-1
2.1.1 Subpackage 1	2-2
2.1.2 Subpackage 2	2-10
2.1.3 Fuel Cask Assembly	2-10
2.1.4 Radioisotope Thermoelectric Generator	2-10
2.1.5 Experiments	2-11
2.2 THE DATA SUBSYSTEM	2-12
2.2.1 Earth-To-Moon Command Transmission	2-13
2.2.1.1 Command Signal Processing	2-13
2.2.1.2 Command Signal Decoding	2-14
2.2.2 Moon-To-Earth Telemetry	2-14
2.2.2.1 The Data Processor	2-15
2.2.2.2 The Transmitter	2-15
2.2.3 Power Distribution	2-15
2.3 THE ELECTRIC POWER SUBSYSTEM	2-16
2.3.1 EPS Functional Description	2-16a
2.4 PASSIVE SEISMIC EXPERIMENT (PSE)	2-16c
2.4.1 Experiment Description	2-16c
2.4.2 General Design Constraints	2-17
2.4.3 Sensor Assembly	2-19
2.4.4 Thermal Control	2-19

CONTENTS (CONT.)

	<u>Page</u>
2.5 ACTIVE SEISMIC EXPERIMENT (ASE)	2-20
2.5.1 Experiment Description	2-20
2.5.2 Experiment Design	2-22
2.5.2.1 Thumper/Geophone Assembly	2-22
2.5.2.2 Mortar Package Assembly (MPA)	2-22
2.6 CHARGED-PARTICLE LUNAR ENVIRONMENT EXPERIMENT (CPLEE)	2-24
2.6.1 Experiment Concept	2-25
2.6.2 Design Requirements	2-26
2.7 LUNAR HEAT FLOW EXPERIMENT (HFE)	2-26
2.7.1 Experiment Description	2-28
2.7.2 Construction and Thermal Control	2-28
2.8 LUNAR SURFACE MAGNETOMETER EXPERIMENT	2-32
2.8.1 LSM Physical Description	2-32
2.8.2 LSM Functional Description	2-33
2.9 SUPRATHERMAL ION DETECTOR EXPERIMENT	2-37
2.9.1 SIDE Physical Description	2-39
2.9.1 SIDE Functional Description	2-40
2.10 SOLAR WIND EXPERIMENT	2-42
2.10.1 SWE Physical Description	2-42
2.10.2 SWE Functional Description	2-45
2.11 COLD CATHODE GAUGE EXPERIMENT	2-49
2.11.1 CCGE Physical Description	2-49
2.11.2 CCGE Functional Description	2-51
2.12 APOLLO LUNAR SURFACE DRILL	2-53

CONTENTS (CONT.)

	<u>Page</u>
2.13 APOLLO LUNAR HAND TOOLS	2-56
3. ALSEP DESIGN	3-1
3.1 SPECIAL DESIGN CONSIDERATIONS	3-1
3.1.1 Thermal Control Constraints	3-1
3.1.2 Reliability Constraints	3-2
3.1.3 Astronaut Interface Constraints	3-2
3.1.4 System Operation Constraints	3-2
3.2 KEY DESIGN FEATURES	3-3
3.3 MATERIAL SELECTION	3-4
3.4 DESIGN VERIFICATION	3-9
3.4.1 The ALSEP Test Program	3-9
3.4.1.1 Test Sequence	3-10
3.4.1.1.1 Development Tests	3-11
3.4.1.1.2 Qualification Tests	3-13
3.4.1.1.3 Acceptance Tests	3-18
3.4.1.2 Conduct of Tests	3-18
3.4.1.2.1 Data and Data Control	3-18
3.4.1.2.2 Data Verification and Approval	3-18
3.4.2 Test Results	3-20
3.4.3 System Reliability	3-20
3.4.3.1 Reliability Goals	3-20
3.4.3.2 Reliability Engineering	3-21

CONTENTS (CONT.)

	<u>Page</u>
3.4.3.2.1 Single-Point Failure Modes	3-22
3.4.3.2.2 Passive Thermal Control	3-22
3.4.3.2.3 Sealed Parts and Vacuum Stable Material	3-22
3.4.3.2.4 Standardization of Parts and Materials	3-23
3.4.3.3 Reliability Test Monitoring and Assessment	3-23
3.5 DESIGN CERTIFICATION	3-24
3.5.1 Design Analyses	3-24
3.5.2 Design Reviews	3-24
3.5.3 Test Readiness Reviews	3-25
3.5.4 Test Results	3-25
4. PROGRAM DESCRIPTION	4-1
4.2 FLIGHT SYSTEMS	4-8
4.2.1 Design Development	4-8
4.2.2 Array A	4-12
4.2.2.1 Prototype A	4-12
4.2.2.2 Qualification Model A	4-17
4.2.2.3 Consolidated Qualification Model (Qual SA)	4-19
4.2.2.4 Array A Flight 1	4-26
4.2.2.5 Array A Flight 2	4-34
4.2.3 Array B	4-37
4.2.3.1 Prototype B	4-37
4.2.3.2 Qualification B	4-38
4.2.3.3 Array B Flight 3	4-41

CONTENTS (CONT.)

	<u>Page</u>
4.2.4 Array C	4-52
4.2.4.1 Prototype C	4-52
4.2.4.2 Qualification C	4-54
4.2.4.3 Array C Flight 4	4-56
4.2.5 Array A-2	4-69
5. RESULTS	5-1
5.1 ARRAY A	5-1
5.2 ARRAY B	5-1
5.3 ARRAY C	5-1
5.4 ARRAY A-2	5-1
APPENDIX A LIST OF ALSEP TECHNICAL MEMORANDUMS	A-1/A-39
APPENDIX B LIST OF ALSEP TEST REPORTS	B-1/B-17
APPENDIX C CENTRAL STATION ELECTRONICS EFFECTIVITIES	C-1
APPENDIX D ALSEP SERIAL NO. ALLOCATION	D-1/D-22

ILLUSTRATIONS

<u>Figure</u>	<u>Title</u>	<u>Page</u>
1	ALSEP/Lunar Module Interface	2-1
2	ALSEP Subpackage 1 (Array A and A-2 Configuration)	2-4
3	ALSEP Subpackage 1 (Array B Configuration)	2-5
4	ALSEP Subpackage 1 (Array C Configuration)	2-6
5	ALSEP Subpackage 2 (Array A and C Configuration)	2-7
6	ALSEP Subpackage 2 (Array B Configuration)	2-8
7	ALSEP Subpackage 2 (Array A-2 Configuration)	2-9
8	Fuel Case Assembly	2-11
9	ALSEP Data Subsystem	2-12
2.3-1	Electrical Power Subsystem, Functional Block Diagram	2-16a
10	Passive Seismic Experiment, Functional Block Diagram	2-18
11	Active Seismic Experiment, Functional Block Diagram	2-21
12	Charged Particle Lunar Environment Experiment, Functional Block Diagram	2-25
13	Heat Flow Experiment, Functional Block Diagram	2-30
2.8-1	Magnetometer Experiment, Functional Block Diagram	2-34
2.8-2	LSM Data Handling Functional Block Diagram	2-36
2.9-1	Suprathermal Ion Detector Experiment, Functional Block Diagram	2-40
2.10-1	SWE, Faraday Cup Diagram	2-45
2.10-2	SWE, Functional Block Diagram	2-48
2.11-1	CCGE, Functional Block Diagram	2-52
14	Major Mechanical Design Features	3-5
15	ALSEP Test Program, Flow Diagram	3-11
16	Prototype Test Program, Flow Diagram	3-14
17	Prototype Component Tests, Flow Diagram	3-14
18	Prototype Central Station Integration Tests, Flow Diagram	3-15
19	Prototype Experiment Tests, Flow Diagram	3-16
20	Prototype System Integration and Tests, Flow Diagram	3-16
21	System Level Qualification Tests, Flow Diagram	3-17
22	Flight System Acceptance Tests, Flow Diagram	3-19
23	Component Acceptance Tests, Flow Diagram	3-19
24	Experiment Acceptance Tests, Flow Diagram	3-19
25	ALSEP Program Schedule	4-3
26	ALSEP Program Schedule	4-4
27	ALSEP Program Schedule	4-5
28	ALSEP Program Schedule	4-6
29	ALSEP Program Summary	4-7

TABLES

<u>Table</u>	<u>Title</u>	<u>Page</u>
1	Experiment Mission Assignment	2-3
2.3-1	Electrical Power Subsystem, Leading Particulars	2-16b
2	PSE Physical Parameters	2-18
3	PSE Power Requirements	2-18
4	ASE Parameters	2-23
5	ASE Power Requirements	2-24
6	CPLEE Design Requirements	2-27
7	HFE Performance Requirements	2-29
2.10-1	SWE, Leading Particulars	2-44
2.11-1	CCGE Leading Particulars	2-50
2.12-1	ALSD Leading Particulars	2-54
8	Key Features of and Materials Selected for Major Subpackage Components	3-6/3-7
9	Special ALSEP Surface Materials	3-8
10	Development Test Program	3-12
11	ALSEP 1 Equipment Reliability Prediction	3-21
12	ALSEP Operational Status	5-2

1. INTRODUCTION

The objectives of lunar surface exploration as it was to be carried out as a part of the Apollo program were defined by the National Academy of Sciences Space Science Board and by National Aeronautics and Space Administration Lunar Exploration and Science Conferences during the time period 1963 to 1965. The Space Science Board meeting at Woods Hole, Massachusetts in June of 1965 undertook a study of certain principal areas of space research, and lunar exploration. At this meeting, 15 major questions associated with exploration of the moon were established. These questions pertained to: (1) the structure and process of the lunar interior, (2) the composition and structure of the surface of the moon and the processes modifying its surface, and (3) the history or evolutionary sequence of events by which the moon has arrived at its present configuration.

In July of 1965, the National Aeronautics and Space Administration conducted a Lunar Exploration and Science Conference at Falmouth, Massachusetts to consider the specific approaches to be taken in each of the disciplinary areas. The groups considered various exploration techniques and the investigations and experiments to be conducted.

From the definition of scientific problems, experiments to be conducted, and the specific lunar locations to be visited, consideration turned to specific lunar surface exploration system concepts, i. e., the particular combination of scientific experiment hardware by which the scientific data was to be obtained in lunar missions.

Beginning in August 1965, preliminary design tasks were performed in parallel by three contractors (Aerospace Systems Division of The Bendix Corporation, Ann Arbor, Michigan; Space-General Corporation, El Monte, California; and TRW, Incorporated, Los Angeles, California) to define the lunar surface science support systems. In March 1966, Aerospace Systems Division was selected by the NASA Manned Spacecraft Center as prime contractor for the design, integration, test, and systems management of the scientific exploration system known as the Apollo Lunar Surface Experiments Package (ALSEP). ALSEP instruments were to be carried to the moon on the Apollo spacecraft and set up on the lunar surface by the Apollo crew. Using a self-contained power supply and communications equipment, each ALSEP system was to collect and transmit to earth scientific and engineering data for extended periods of time following astronaut departure.

The basic science data to be obtained by the ALSEP systems were to define:

1. the internal structure and composition of the moon;
2. heat flow from the lunar interior;
3. tectonic processes and meteorite impacts, with an assessment of their importance in the genesis of surface features;
4. near-surface geologic structure;
5. the existence and nature of the moon's magnetic field;
6. the interaction of the solar plasma with the moon's magnetic field;

7. the nature of and variations in the lunar gravitational field;
8. characteristics of particulate solar radiation reaching the lunar surface;
9. the nature of the earth's magnetospheric tail;
10. the nature of the tenuous lunar atmosphere and the composition of gases released by tectonic and impact processes; and
11. the precise orbit and libration pattern of the moon.

Design of the ALSEP systems was governed by the following guidelines and constraints:

1. Operating lifetime of one year.
 2. Deployability of experiments and supporting subsystems within astronaut capabilities and safety constraints.
 3. Capability of withstanding the natural and induced mission environments (launch, boost, and descent vibration and shock; lunar surface temperature variations between +250°F and -300°F; lunar surface dust; vacuum).
 4. Capability of full operation during both lunar day and lunar night.
 5. Operating capability with Manned Space Flight Network¹ telemetry ground stations, with a downlink bit error rate of 10^{-4} or less and an uplink bit error rate of 10^{-9} or less.
 6. Compatibility with Lunar Module interfaces (internal volume of 15 cubic feet, system weight constraints of about 300 pounds, and stowed center-of-gravity constraints).
 7. Capability of deployment at lunar longitudes of ± 45 degrees and latitudes of ± 25 degrees.
 8. Deployability at sun angles of 7 to 25 degrees.
 9. Maintainability of system thermal control when all exposed surfaces are degraded by dust or ultraviolet radiation.
 10. Capability of withstanding extended ground testing without damage.
- 1 - Subsequently redesignated the Spaceflight Tracking and Data Network (STDN)

2. ALSEP DESCRIPTION

2.1 ALSEP FLIGHT SYSTEM DESCRIPTION

Four ALSEP system configurations were developed in response to the basic contract. These configurations were designated Array A, Array B, Array C, and Array A-2. Each ALSEP system consists of a selection of experiments stowed in two subpackages, and a fuel cask assembly. The two subpackages are stowed within the scientific equipment (SEQ) bay of the Lunar Module (LM) as illustrated in Figure 1 for transport to the moon. The experiment complement, Apollo flight assignment, and lunar deployment location for each of the ALSEP systems is listed in Table 1. The subpackage configurations are illustrated in Figure 2 through 7.

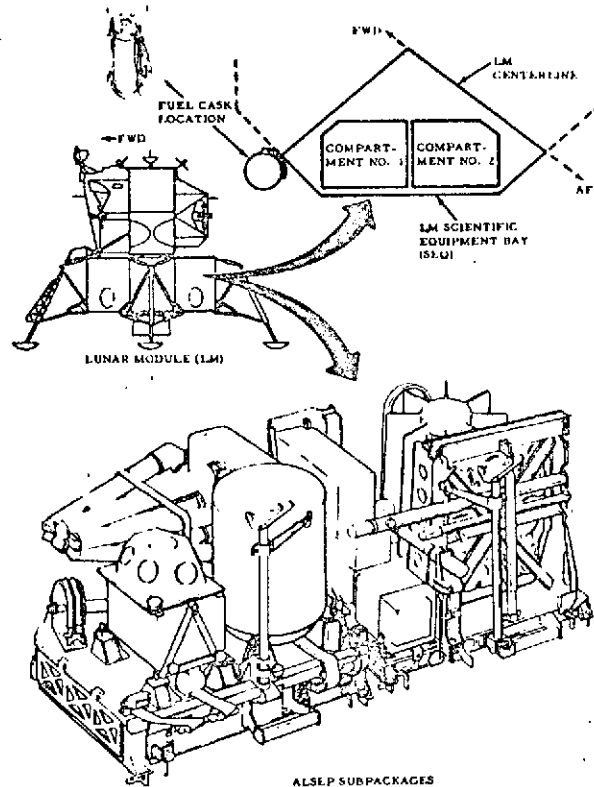

Figure 1 ALSEP/Lunar Module Interface

Each subpackage is approximately 24x27x21 inches in size, and the combined volume is about 15 cubic feet. A four-point LM interface, two bullet pins on the rear and two latch bars on the front, is provided for locking the ALSEP subpackages in place. The astronaut releases each package from the LM and lowers it to the lunar surface by pulling on a single lanyard. He transports them "barbell" style, connected at their bases with a carry bar, to the ALSEP deployment site. Both packages also have a handle and can be carried suitcase style in a contingency situation.

On the moon, the ALSEP system collects scientific and engineering data, encodes these data, and transmits them to earth in the form of a continuous downlink radio signal. On the earth, the signal is received and the data are extracted and subjected to engineering evaluation and scientific analysis. The engineers and

scientists may decide, from the data and previously established ground rules, to modify ALSEP operation by transmitting uplink radio commands. This remote-control capability, using feedback from actual measurements with human judgment in the loop, results in a high degree of ALSEP flexibility and versatility.

The ALSEP system has no provision for data storage other than shift registers, so all measurements are transmitted to earth almost immediately and recorded promptly. Recording is done on magnetic tape 24 hours a day at one of the several S-band receiving stations in the worldwide Manned Space Flight Network (MSFN) of the National Aeronautics and Space Administration (NASA). The tapes are shipped to the NASA Manned Spacecraft Center (MSC) in Houston, Texas, for further processing and distribution.

At scheduled intervals, live data are relayed from the receiving station - through the NASA Goddard Space Flight Center (GSFC) - to the Mission Control Center (MCC) at MSC for real-time monitoring, evaluation, and control. At the Control Center, the incoming data words are sorted and converted for presentation on a variety of digital and analog displays for operator interpretation and control decisions. When required, a command message is generated by a pushbutton input on a console at Mission Control Center, operating through a computer; this message is relayed through GSFC to the appropriate MSFN station, where a station computer processes it and passes the corresponding bit pattern to the uplink transmitter.

2.1.1 SUBPACKAGE 1

The lower portion of subpackage 1 is a primary structure within which are housed the Central Station Data Subsystem, which include the data handling, r. f. uplink, r. f. downlink, and power distribution subsystems. These subsystems are mounted on a thermal radiating plate, surrounded on five sides by a multilayered superinsulation thermal bag. Immediately above the primary structure is a rigid structural honeycomb plate which is used as an experiment-mounting structure during lunar transit and as a sunshield for the thermal radiating plate after experiment deployment. In the stowed configuration, the sunshield is attached to the primary structure and the experiments are attached to the sunshield with quick-release quarter-turn fasteners capable of providing a preload during the induced-environments portion of the missions. When the experiments are removed, the sunshield is released and self-erects to a height of 27 inches above the thermal plate with the aid of four tubular extension springs. Multilayer aluminized-Mylar and Kapton superinsulation side curtains automatically unfold as the sunshield rises and cover the east and west sides of the package. These side curtains prevent sunlight from falling directly on the thermal radiating plate. On missions at lunar latitudes greater than 5 degrees, a third side curtain is added to the side of the package facing the lunar equator.

In the erected configuration, the electronic and thermal portions of subpackage 1 are referred to as the Central Station. Flat conductor cables are used to connect the experiments to the Central Station. Kapton-covered cable was selected because

Table 1 Experiment Mission Assignments

Experiment	Principal Investigator ^a	Mission, Array, Deployment Date, and Landing Site						
		* Apollo 11 EASEP 20 July 1969 Mare Tranquillitatis (23.5°E, 0.6°N)	Apollo 12 ALSEP A 19 November 1969 Oceanus Procellarum (23.4°W, 3.2°S)	Apollo 13 ALSEP B (Mission Aborted)	Apollo 14 ALSEP C 5 February 1971 Fra Mauro (17.5°W, 3.7°S)	Apollo 15 ALSEP A-2 31 July 1971 Hadley Rille (3.6°E, 26.1°N)	* Apollo 16 ALSEP D April 1972 Descartes (15.5°E, 8.9°S)	* Apollo 17 ALSEP E December 1972 Taurus Littrow (30.8°E, 20.2°N)
Passive Seismic Experiment (PSE)	Gary Latham Lamont-Doherty Geological Observatory, Columbia Univ.	⊙	⊙	⊙	⊙	⊙	⊙	
Laser-Ranging Retroreflector (LRRR) • 100 Corner	* J. E. Faller Wesleyan University	⊙			⊙			
• 300 Corner	*					⊙		
Lunar Surface Magnetometer (LSM)	Palmer Dyal Ames Research Center		⊙			⊙	⊙	
Solar Wind Spectrometer (SWS)	Conway W. Snyder Jet Propulsion Laboratory		⊙			⊙		
Suprathermal Ion Detector Experiment (SIDE)	John Freeman Rice University		⊙		⊙	⊙		
Heat Flow Experiment (HFE)	Mark Langseth Lamont-Doherty Geological Observatory, Columbia Univ.			⊙		⊙	⊙	⊙
Charged-Particle Lunar Environment Experiment (CPLEE)	B. O'Brien/D. Reasoner Rice University			⊙	⊙			
Cold-Cathode Ion Gage Experiment (CCGE)	Francis Johnson University of Texas			⊙				
Active Seismic Experiment (ASE)	Robert Kovach Stanford University				⊙		⊙	
Lunar Seismic Profiling Experiment (LSP)	* Robert Kovach Stanford University							⊙
Lunar Surface Gravimeter (LSG)	* Joseph Weber University of Maryland							⊙
Lunar Mass Spectrometer (LMS)	* John H. Hoffman University of Texas							⊙
Lunar Ejecta Meteoroid Experiment (LEAM)	* Otto Berg Goddard Space Flight Center							⊙
Dust Detector (DD)	James Bates Manned Spacecraft Center	⊙	⊙	⊙	⊙	⊙		

^aFor most experiments, a team of co-investigators is responsible for definition of experiment requirements and interpretation of science data; only the principal investigator is listed here.

* Developed under separate contract. Not covered in this report.

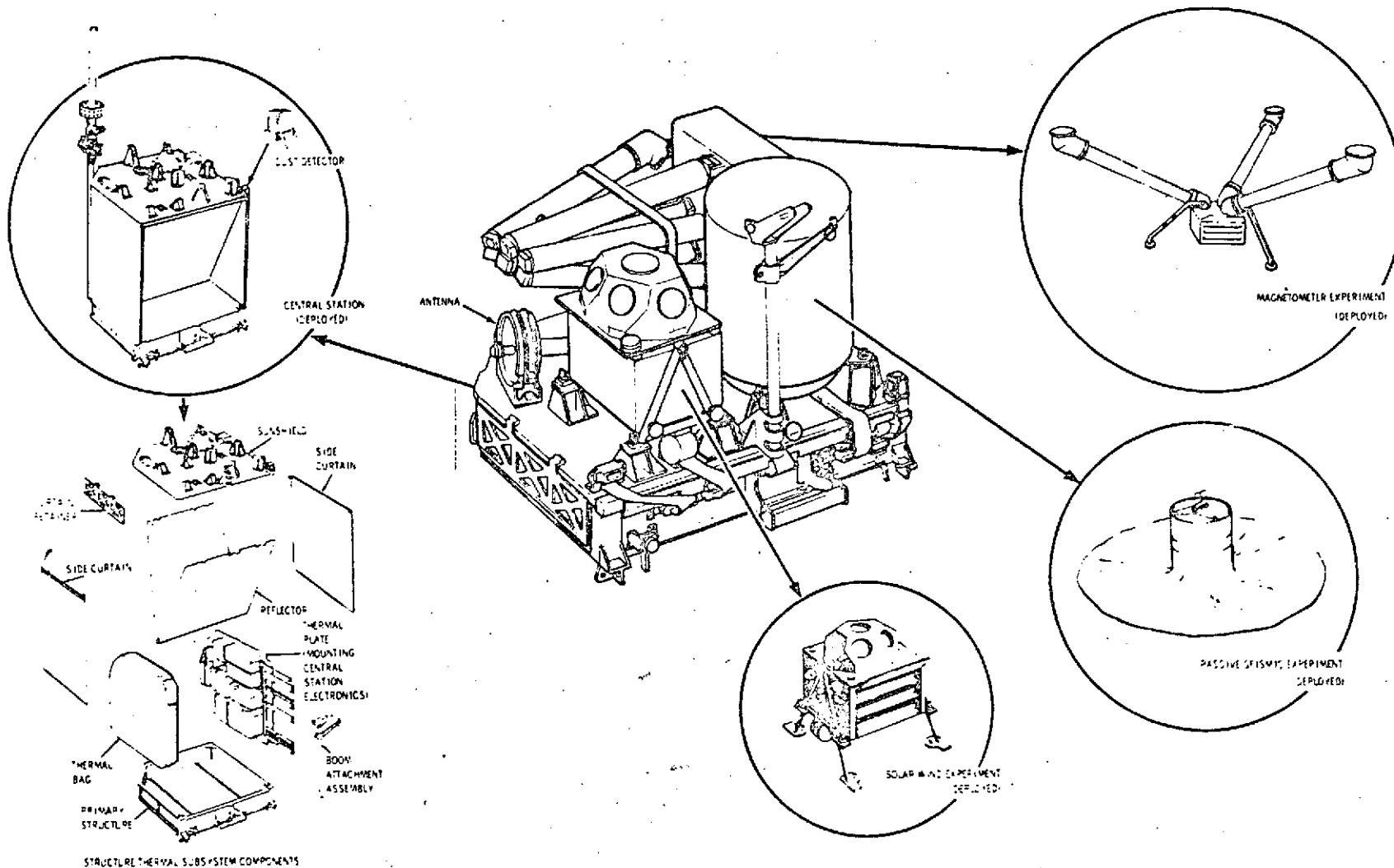

Figure 2 ALSEP Subpackage 1 (Array A and A-2 Configuration)

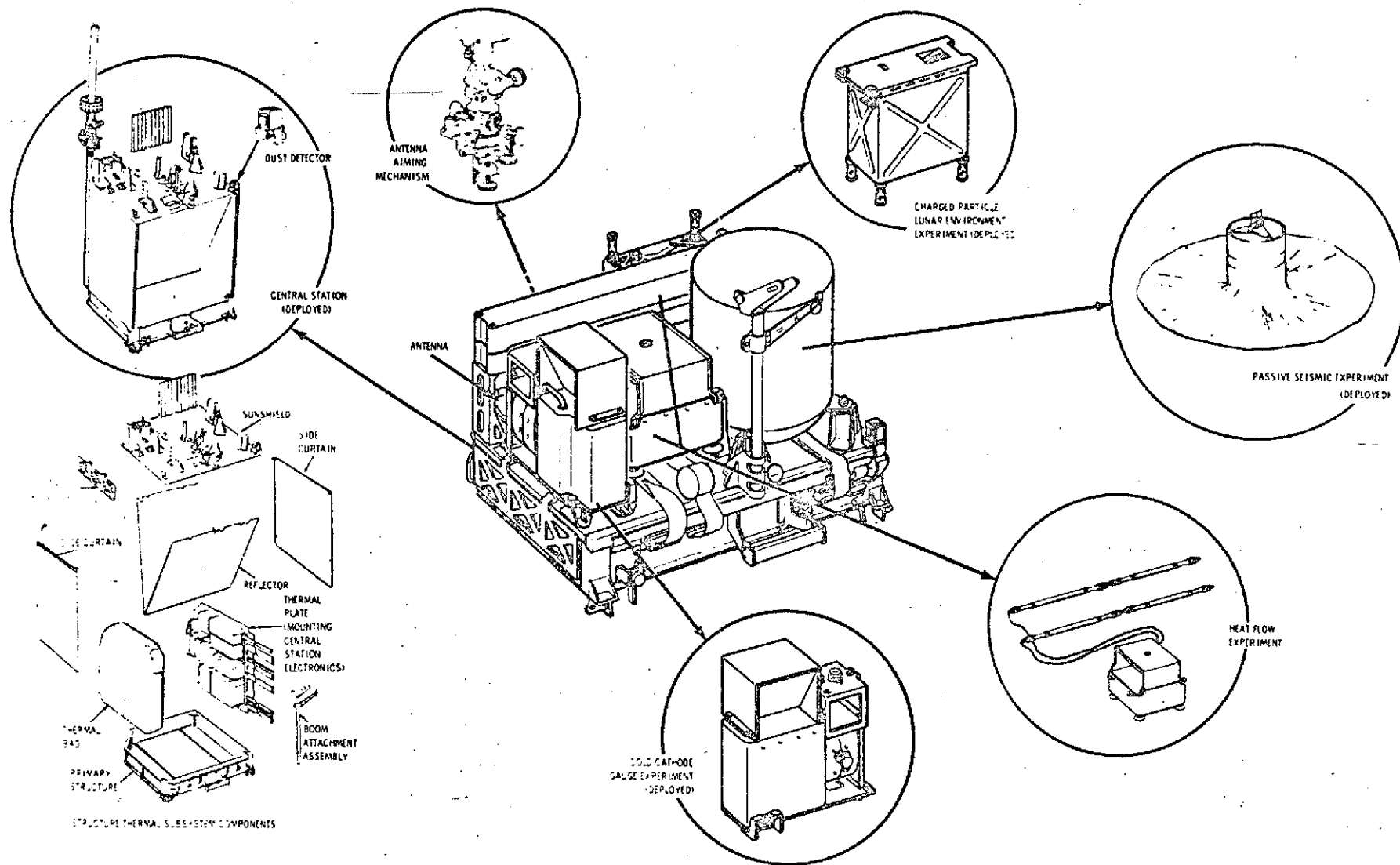

Figure 3 ALSEP Subpackage 1 (Array B Configuration)

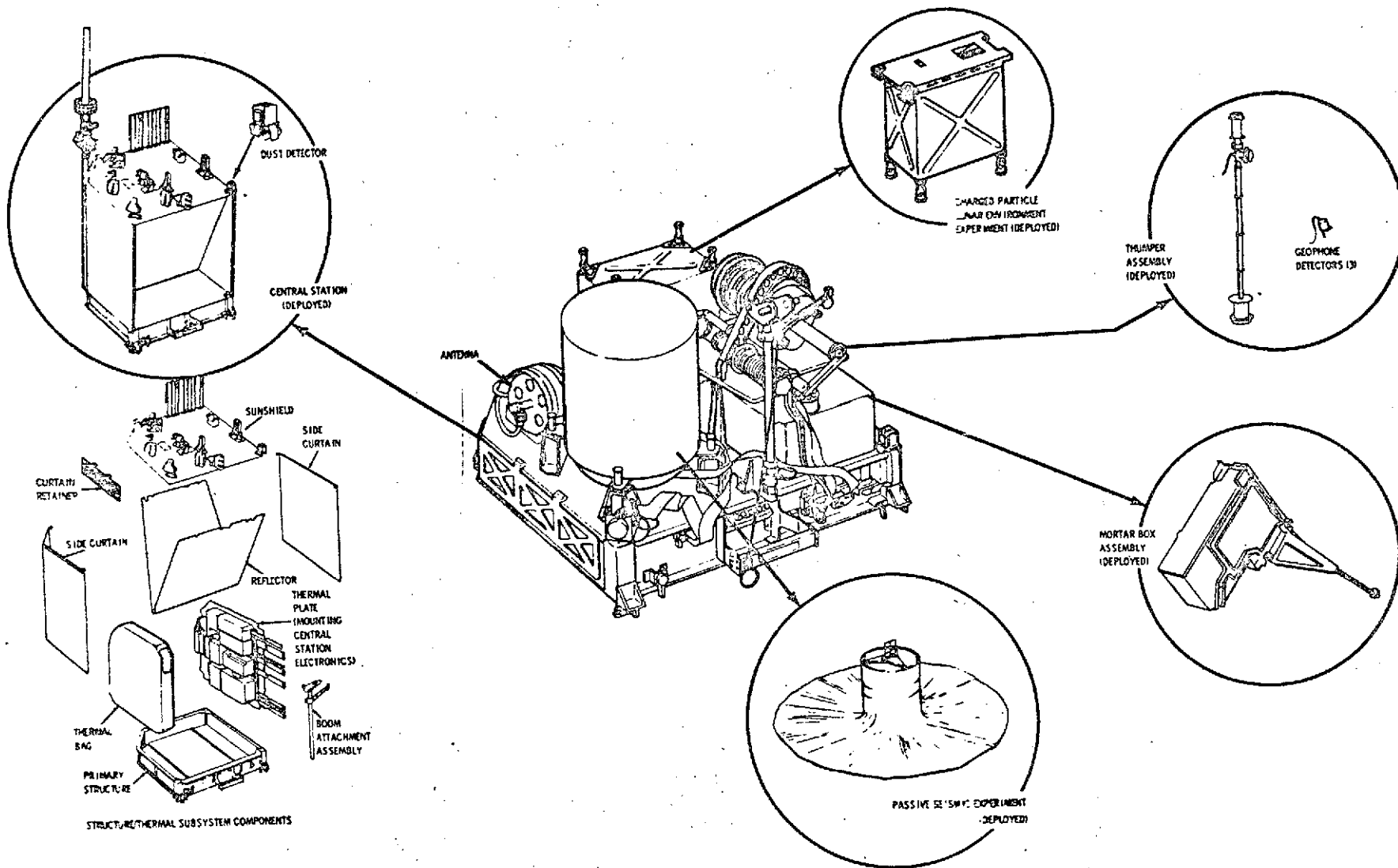

Figure 4 ALSEP Subpackage 1 (Array C Configuration)

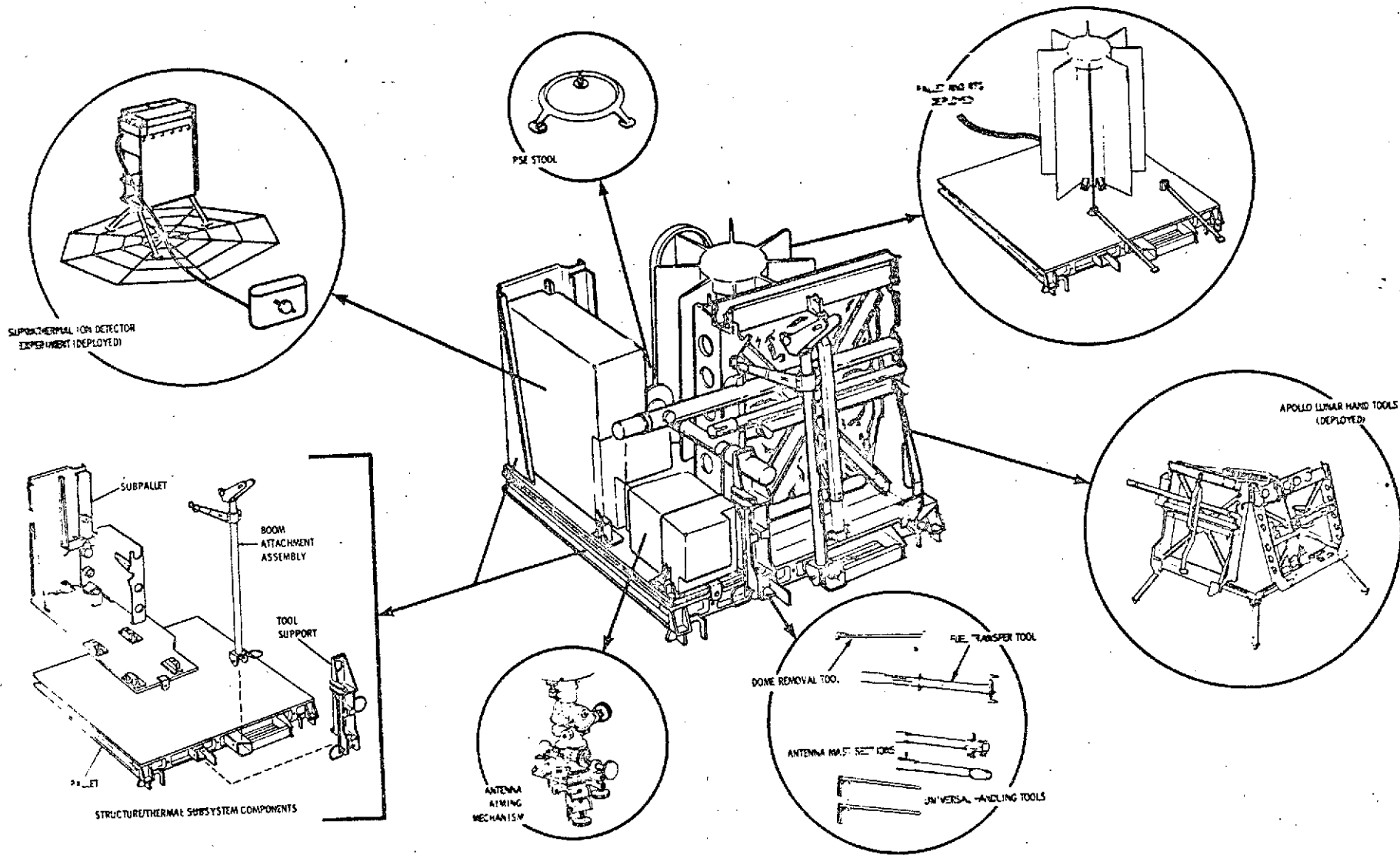

Figure 5 ALSEP Subpackage 2 (Array A and C Configuration)

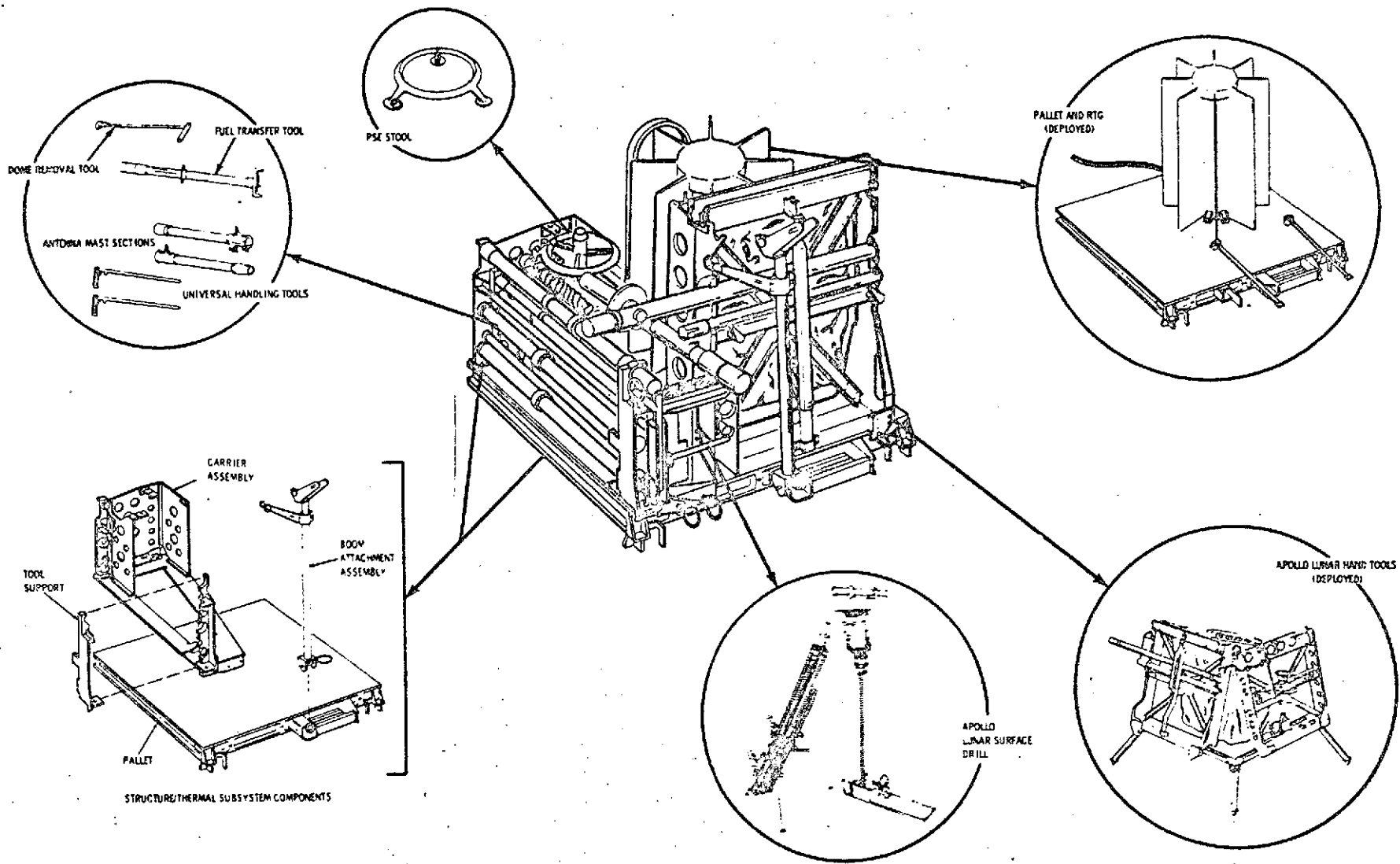

Figure 6 ALSEP Subpackage 2 (Array B Configuration)

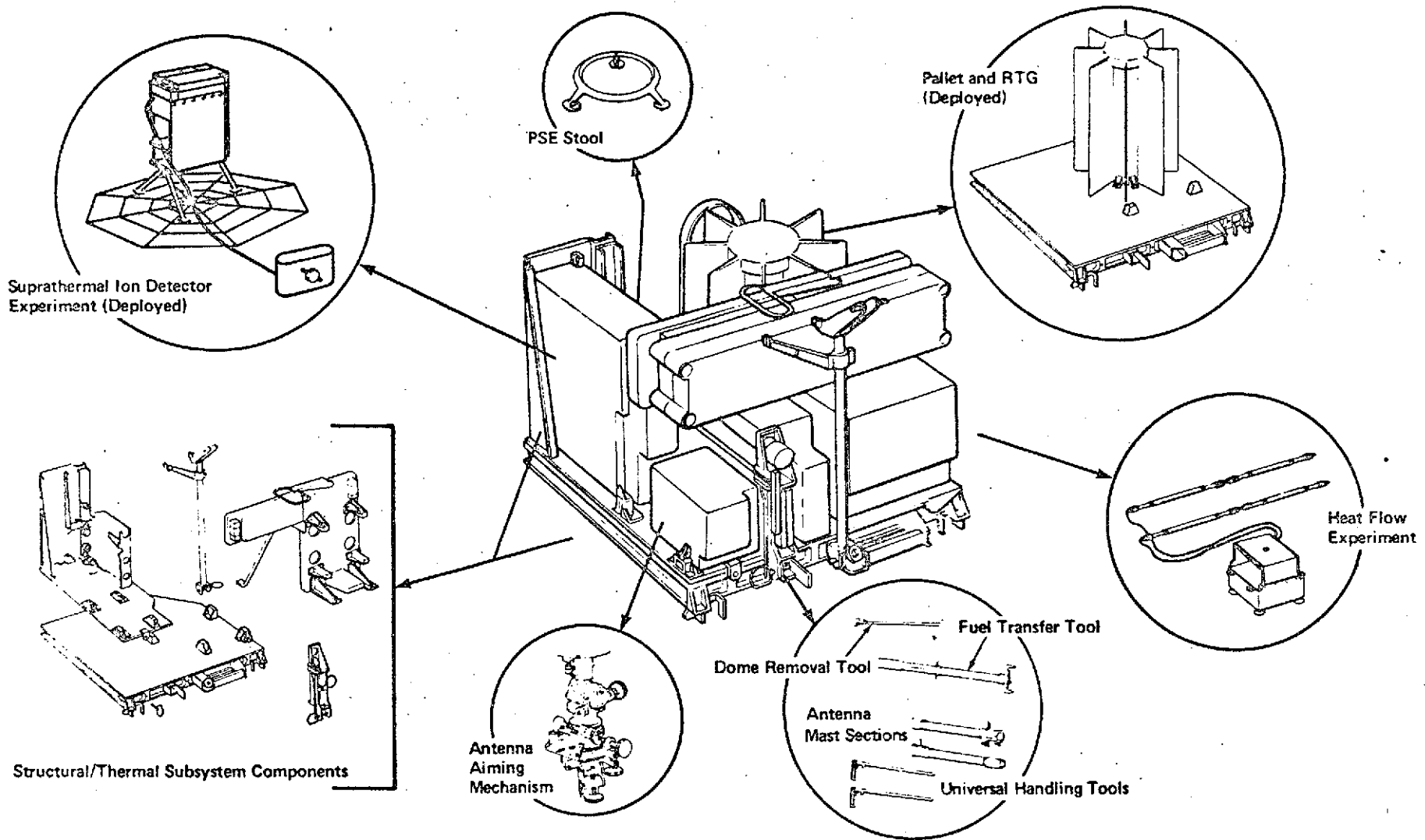

Figure 7 ALSEP Subpackage 2 (Array A-2 Configuration)

of its excellent electrical and mechanical properties and its low weight. Cable lengths for the various experiments vary from 10 to 70 feet, in accord with scientific requirements for avoiding mutual interference. The cable is stowed in cable reels mounted either under or beside each experiment.

A helical S-band antenna is also carried on subpackage 1. The antenna is attached to an aiming mechanism and an antenna mast, which in turn is locked into the primary structure. The aiming mechanism provides for leveling of the antenna platform, alignment to the sunline, and positioning in azimuth and elevation to yield an overall antenna-pointing-accuracy capability of ± 1 degree.

2.1.2 SUBPACKAGE 2

Subpackage 2 consists of a rigid structural pallet on which are mounted one or two experiments, together with the SNAP-27 radioisotope thermoelectric generator (RTG) assembly, the antenna-aiming mechanism, special ALSEP deployment tools, and - on two Apollo flights - an astronaut geologic-hand-tool carrier. The generator assembly is permanently attached to the aluminum pallet; all other equipment is attached to subpallets and removed from the pallet early in deployment. This arrangement minimizes astronaut activity near the generator assembly during its warm-up cycle. The removable equipment is tied down with quick-release fasteners. The special tools include two universal handling tools used for releasing fasteners and for carrying experiments and other equipment, a dome removal tool, a fuel transfer tool, and a dual-purpose carry bar and antenna mast.

2.1.3 FUEL CASK ASSEMBLY

The fuel cask assembly, shown in Figure 8, has five major components: a graphite fuel cask, a cask band assembly, the mounting structure, a heat shield, and an astronaut guard. The structure, which provides tie points for attaching the fuel cask to the exterior of the Lunar Module, is equipped with a thermal shield that reflects fuel-capsule thermal radiation away from the Lunar Module. The cask bands, clamped onto the cask, provide tie points for its attachment to the structure. The lower band incorporates a mechanism for filtering the fuel cask to gain access to the fuel capsule. The guard prevents astronaut contact with the 800°F cask during deployment.

Two temperature transducers monitor thermal-shield temperatures, and, in turn, assembly temperatures, during prelaunch and flight for transmittal through the LM telemetry system.

2.1.4 RADIOISOTOPE THERMOELECTRIC GENERATOR

The SNAP-27 radioisotope thermoelectric generator (RTG) system was developed specifically to accommodate the ALSEP mission. The system was developed by the General Electric Company for the U.S. Atomic Energy Commission, which provided it to the National Aeronautics and Space Administration.

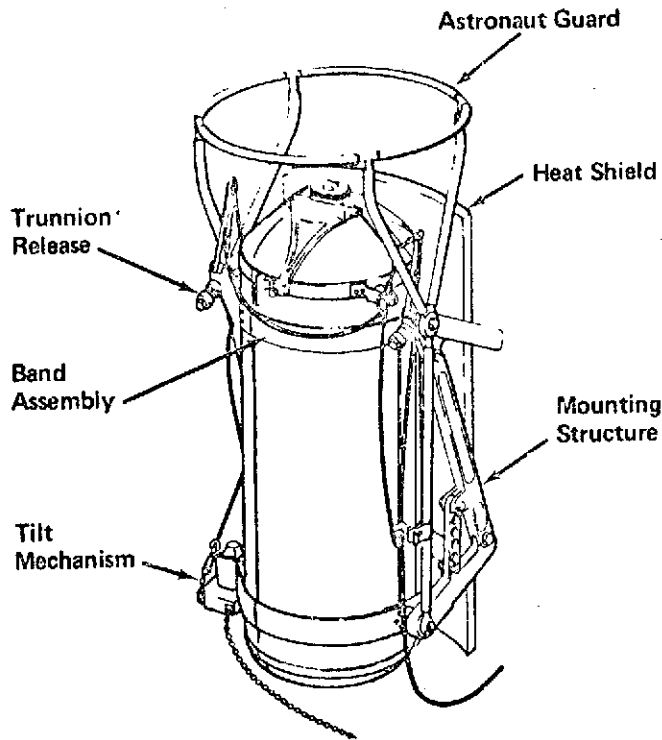

Figure 8 Fuel Cask Assembly

2.1.5 EXPERIMENTS

The eight experiment subsystems which were developed to accomplish specific lunar research are listed in Table 1 and their ALSEP System assignments are indicated. Four of these experiment subsystems were developed under contract by BxA, and four were government furnished equipment. The BxA developed experiment subsystems are:

1. The Passive Seismic Experiment (PSE)
2. The Active Seismic Experiment (ASE)
3. The Charged-Particle Lunar Environment Experiment (CPLEE)
4. The Heat Flow Experiment (HFE)

The Government furnished experiment subsystems are:

1. The Lunar Surface Magnetometer (LSM)
2. The Solar Wind Spectrometer (SWS)
3. The Supra-Thermal Ion Detector Experiment (SIDE)
4. The Cold Cathode Gauge Experiment (CCGE).

2.2 THE DATA SUBSYSTEM

The data subsystem (DSS) is the focal point for control of the ALSEP experiments and for the collection, processing, and transmission to the Manned Space Flight Network (MSFN) of scientific and engineering-status data. The subsystem consists of a series of integrated units, interconnected as shown in Figure 9, which function to receive and decode uplink (earth-to-moon) commands, to time and control experiment subsystems, and to collect and transmit the downlink (moon-to-earth) data. The antenna receives the uplink command signals and routes them through the diplexer to the command receiver and then to the command decoder for address recognition, decoding, and command execution. Downlink data transmission is accomplished via the data processor, the transmitter, the diplexer, and the antenna. The DSS is designed with sufficient flexibility to interface with and to collect and process data from up to five of nine different experiment subsystems for each mission.

The components of the data subsystem are mounted on a thermal plate 23.25 inches by 20 inches in size. The plate also accommodates the central electronics for two experiments. The components are linked electrically by a preformed harness through connectors having multiple pins (up to 244). Coaxial cables link the command receiver and transmitters to the diplexer switch and filter and thence to the antenna. The entire assembly is thermally insulated to maintain a temperature range of 0 to 135°F throughout the lunar day/night cycle.

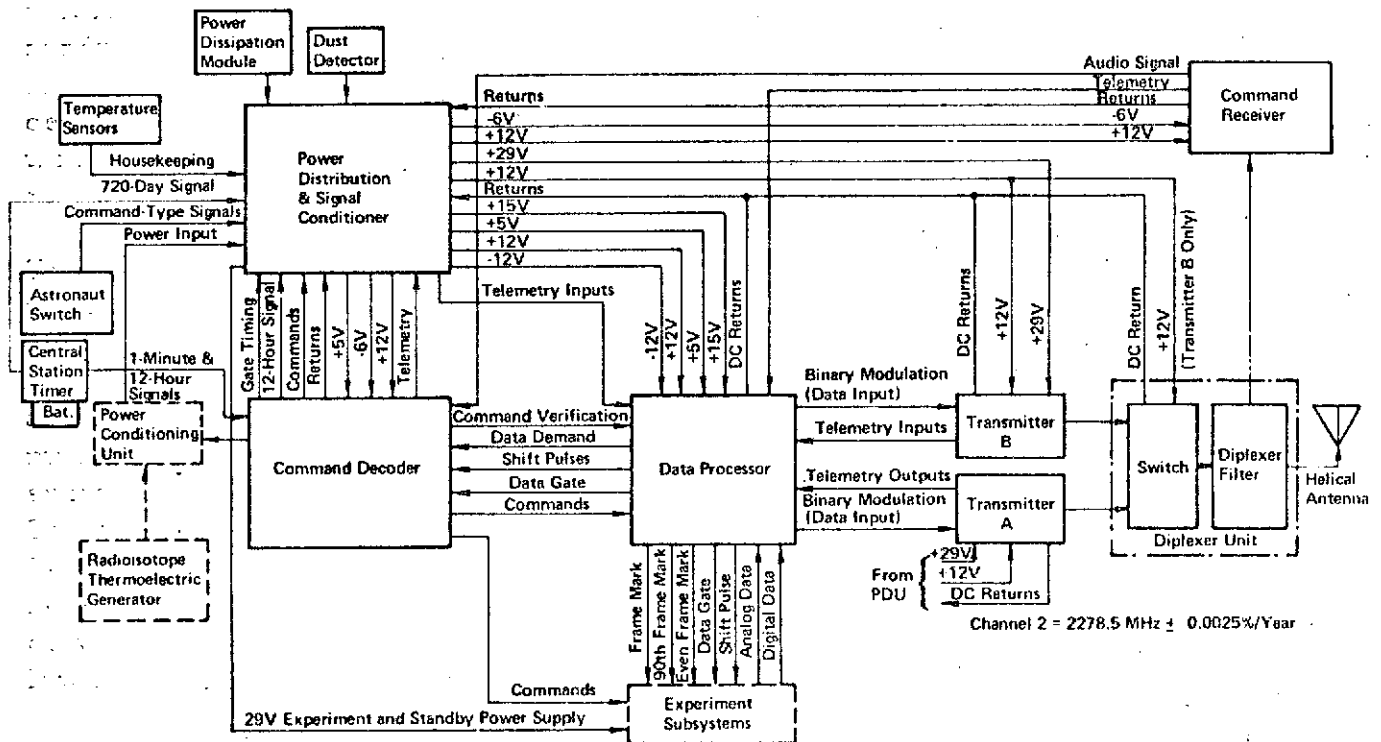

Figure 9 ALSEP Data Subsystem

The Central Station - the name assigned to the data subsystem and associated units - also incorporates temperature sensors, manual control switches, and thermal plate heaters. The manual control switches permit the astronaut to start system operation in the event that the uplink cannot be established.

2.2.1 EARTH-TO-MOON COMMAND TRANSMISSION

ALSEP system control is exercised through commands transmitted by the Manned Space Flight Network (MSFN); these commands are checked for proper address and for command bit error, then decoded and routed to the proper experiment subsystem. The components that form the command link are designed to achieve a bit error probability of 10^{-9} in recognizing and decoding command messages.

2.2.1.1 COMMAND SIGNAL PROCESSING

The command data are transmitted by the MSFN at a frequency of 2119 megahertz. The carrier, modulated with a 2-kilohertz subcarrier and a 1-kilohertz synchronizing subcarrier, is received by the DSS antenna, routed through the diplexer, demodulated by the command receiver, decoded by the command decoder, and applied to the appropriate experiment and support subsystems as discrete commands. These commands control the operation of the experiment and its subsystems and initiate command verification functions.

The antenna is a modified axial helix, designed to receive and transmit a circularly polarized S-band signal with an approximate gain of +15 decibels and a 3-decibel bandwidth of approximately 30 degrees. The antenna is mounted on a gear-driven gimbal platform that enables the astronaut to aim the antenna pattern toward the center of the earth's libration pattern. A diplexer filter connects the antenna through a low-loss path to the command receiver and simultaneously isolates the receiver from the transmitter output.

The receiver is a single-conversion device having a noise figure sufficient to meet the system P_e specification and to provide a margin of 6 to 8 decibels, with nominal performance of all parts of the link. Two local-oscillator/driver-amplifier circuits (designated A and B) provide operational redundancy. A level-sensor and local-oscillator switch circuit determines which local oscillator supplies the mixing signal; the level sensor monitors the local-oscillator signal and automatically switches to the redundant oscillator when signal level drops below a preset value. The receiver output, a 2-kilohertz command-data subcarrier modulated with a 1-kilohertz synchronization signal, is applied to the command decoder. Selected receiver parameters, including temperature, local-oscillator signal level, received signal level, circuit-A local-oscillator level, circuit-B local-oscillator level, and 1-kilohertz output are monitored in the downlink.

2.2.1.2 COMMAND SIGNAL DECODING

The command decoder receives the combined 2-kilohertz command-data sub-carrier and 1-kilohertz synchronization signal from the command receiver, demodulates the subcarrier to provide digital timing and command data, and searches for proper address; upon address recognition, it decodes the command data and applies discrete commands to the appropriate experiment or subsystem.

Reliability is enhanced by redundant subsections that provide alternate paths (A and B) for decoding a command message. The two subsections function identically, but their address gates respond to different address information so the MSFN operator may select either one to decode and process a command. Reliability is further enhanced by a delayed-command sequencer that provides an automatic means for the local generation of commands in the event of uplink failure.

Each ALSEP system is assigned a unique address, with a separate address for each of the two sections of the command decoder. A command message consists of a 20-bit (1-kilobit-per-second) preamble, a 7-bit decoder command address, the command complement (7 bits), a 7-bit command, and a final 20 bits for timing the command-execution period. The 20-bit preamble provides time for the demodulator to acquire phase lock, enable the NRZ-C bit stream to the decoder shift register, and activate address search. Following reception of a valid address, the 7-bit command complement is shifted into the register. While this is happening, a bit-by-bit comparison is made between the command complement and the command. If the comparison is true, a ONE is inserted into one stage of the register and an EXECUTE signal activates decoding and execution of the command. This technique ensures that only valid commands are executed. Following its execution, the command is held in the register until a data demand is received from the data processor, whereupon the 7-bit command and the ONE are inserted in the telemetry signal for transmission to earth. By checking this command verification word (CVW), the operator can verify that a valid command was received by the system and can identify the command that was decoded.

Of the 128 combinations available from the 7-bit command, 100 are used to control the system. Each of the 100 commands is provided to the user through its own line driver.

The electronics, which are packaged on multilayer printed-circuit boards (up to twelve layers thick), have a weight of 2.7 pounds and occupy a 69-cubic-inch volume. Their operating power is 1.3 watts.

2.2.2 MOON-TO-EARTH TELEMETRY

The telemetry signal is biphase-modulated with the science and engineering data. The components associated with data collection, organization, and transmission are the data processor and the transmitter.

2.2.2.1 THE DATA PROCESSOR

The data processor generates ALSEP timing and control signals, collects and formats both analog and digital data, and provides pulse-coded (PCM) data to modulate the downlink transmission. The processor consists of a digital data processor and an analog multiplexer/converter, the latter for engineering-status data. The two sections are contained in separate packages.

Functionally, either of two redundant data-processing channels may be selected to perform the data processing function. The digital data are applied directly to the processor channels. The analog (engineering) data are applied to a 90-channel analog multiplexer, where each of 90 data sources is sampled once every 54 seconds, the data being then digitized and transmitted to earth. The analog-to-digital converters use a ramp-generation technique to encode the analog signal into an 8-bit digital word. A single 8-bit conversion is made for each telemetry frame.

The data processor operates at one of three bit rates: a normal rate of 1060 bits per second, a rate of 10,600 bits per second in conjunction with the Active Seismic Experiment, and a contingency rate of 530 bits per second for improvement in bit error rate with degraded telemetry signal. The bit error probability acceptable for moon-to-earth telemetry is 10^{-4} , a requirement that is more than met by system performance.

To ensure synchronous operation, the data processor supplies a system clock to all experiments. In addition, a frame mark, an even frame mark, a 90th frame mark, and data gate signals can be made available where they are required by experiment design. Each output signal from the data processor is routed through its own line driver, and any failure affects one signal only.

2.2.2.2 THE TRANSMITTER

Each data subsystem is equipped with two identical transmitters that provide standby operational redundancy; either can be selected to transmit the downlink data. Each transmitter generates an S-band frequency carrier, which is biphasemodulated by the coded binary bit stream from the data processor. The transmitter operates at a preselected frequency in the 2275- to 2279-megahertz range, with a stability of 0.0025 percent per year. A minimum r. f. output power of 1 watt is required to meet the downlink error-probability constraint of 10^{-4} or less.

Input current, automatic gain control, and two temperature points are monitored from moon-to-earth telemetry data.

2.2.3 POWER DISTRIBUTION

The power distribution unit (PDU) distributes power to experiment and Central Station components and provides circuit-overload protection and power switching. The unit also conditions selected telemetry signals prior to their input to the multiplexer. All circuits are packaged on five printed-circuit boards. A "mother

board" interconnects these boards to a rectangular, screw-lock, 244-pin connector, through which the electrical inputs are made.

Since the power available to the ALSEP system has a fixed upper limit that must not be exceeded by system power demand, a POWER OFF sequencer is incorporated in the power distribution unit to provide for automatic load adjustment. Reserve power - the difference between the power available and the power in demand at any given time - is continuously monitored in the PDU and referenced to the input voltage. Should this reserve drop below a preset level (nominally 700 milliwatts), a level detector is activated and the power-off (ripple-off) sequence begins.

2.3 THE ELECTRIC POWER SUBSYSTEM

The electric power subsystem (EPS) provides the power for lunar operation of the ALSEP. Primary electrical power is developed by thermoelectric action with thermal energy supplied by a radioisotope source. Primary power is converted, regulated, and filtered to provide six operating voltages for the ALSEP experiment and support subsystems.

The components of the EPS are a radioisotope thermoelectric generator assembly, a fuel capsule assembly, a power conditioning unit, and a fuel cask.

The Radioisotope Thermoelectric Generator (RTG) is a cylindrical case with eight heat rejection fins on the exterior, and a central cavity to receive the fuel capsule. The active elements are a hot frame, a cold frame, and a thermoelectric couple assembly. The thermoelectric couple assembly is located between the hot frame, which surrounds the cavity, and the cold frame, which interfaces with the outer case and heat rejection fins.

The Fuel Capsule Assembly (FCA) is a thinwalled, cylindrical-shaped structure with an end plate for mating and locking in the fuel cask and in the RTG. It contains the radioisotope fuel, plutonium (Pu-238), encapsulated to meet nuclear safety criteria.

The functional elements of the Power Conditioning Unit (PCU) are redundant dc voltage converters and shunt regulators, filters, and two command control amplifiers. The elements are mounted in cordwood modules that are interconnected by printed circuit boards and attached to the center and lower sections of the PCU case.

Shunt regulator load and dissipative elements are mounted in a power dissipation module external to the central station along the back of subpackage No. 1.

A "fuel cask" is used to transport the fuel capsule assembly from the Earth to the Moon. The fuel cask is a cylindrical shaped structure with a screw-on end cover at the top end. The cask provides fuel capsule support elements and a free radiation surface for rejection of fuel capsule heat. The fuel cask provides re-entry protection in case of an aborted mission.

The physical and electrical characteristics of the electrical power subsystem are given in Table 2.3-1.

2.3.1 EPS FUNCTIONAL DESCRIPTION

As shown in Figure 2.3-1, the radioisotope thermoelectric generator (RTG) supplies +16 volts of primary power to the PCU. Voltage conversion circuits in the PCU convert the primary power to the six ALSEP operating voltages. The PCU starts automatically when there is sufficient power for fixed loads.

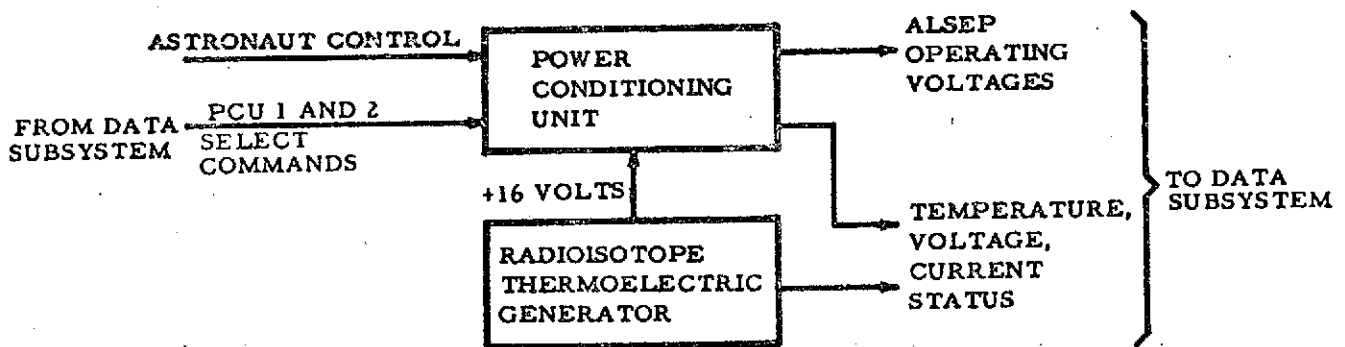

Figure 2.3-1 Electrical Power Subsystem, Functional Block Diagram

The astronaut control is a back-up signal for starting the PCU. PCU #1 and PCU #2 select commands from the data subsystem activate control circuits that switch the redundant circuits of the PCU.

Analog voltages from the RTG and PCU provide temperature, voltage, and current status to the data subsystem.

Table 2.3-1 Electrical Power Subsystem Leading Particulars

Component	Characteristic	Value
Radioisotope Thermoelectric Generator	Output power	63 to 74 watts
	Output voltage	16.1 ± 0.5 vdc
	Hot junction temperature, lunar day	900 to 1100 deg. F
	Cold junction temperature, lunar day	350 to 550 deg. F
	Length	18.12 inches
	Diameter	16 inches
Fuel Capsule	Weight	28 pounds maximum
	Length	16.92 inches
	Diameter	2.6 inches (except end plate)
	Weight	15.46 pounds maximum
Power Conditioning Unit	Thermal output	1430 to 1520 watts
	Nominal outputs	+29 vdc at 1.19 amps
		+15 vdc at 0.08 amp
+12 vdc at 0.30 amp		
+5 vdc at 0.90 amp		
-6 vdc at 0.05 amp		
-12 vdc at 0.15 amp		
Output voltage regulation	± 1 percent	
Fuel Cask	Length	23 inches
	Diameter	8.0 inches
	Weight	25.0 pounds nominal

2.4 PASSIVE SEISMIC EXPERIMENT (PSE)

The PSE developed for ALSEP was designed to detect and lunar surface vibrations, free oscillations, and tidal deformations to extend man's knowledge of the lunar body and of the forces acting upon it. Assignment of the PSE to the ALSEP systems as listed in Table 1 established a seismic network on the moon so that triangulation measurement techniques can be used to determine epicenters and depths of seismic activity.

Gary V. Latham of the Lamont-Doherty Geological Observatory at Columbia University is Principal Investigator for the Passive Seismic Experiment. Instrument design incorporates seismometers previously developed by the Observatory.

2.4.1 EXPERIMENT DESCRIPTION

The PSE is made up of a sensor assembly, central station electronics, thermal shroud, and a leveling stool. The sensor assembly consists of four seismometers: a short-period seismometer to detect vertical motion of the lunar surface over a frequency range of 0.05 to 20 hertz, and three long-period seismometers, mounted orthogonally, to detect wave motion in both vertical and horizontal planes at frequencies of 0.004 to 2.0 hertz. The stillness of the lunar environment - that is, the absence of noise due to winds, ocean tides, machinery, and human activity -

permits these instruments to be designed with far greater sensitivity than earth-based seismometers. The lunar seismometer minimum detectable signal results from ground motion of 0.3 millimicron and is recorded on earth magnified by a factor of 10 million. Measurements of lunar-surface tidal motion and variations in gravity are derived from the triaxial long-period seismometer system by signal filtering. These seven science signals, four seismic, three tidal, plus an eighth for sensor temperature, are transmitted to the PSE central station electronics through a pair of 10-foot 27-conductor flat Kapton-coated tape cables.

The PSE electronics provide power conditioning, thermal control, command logic for controlling experiment functions, and data handling as shown in the functional block diagram, Figure 10.

In the deployed configuration, the sensor assembly rests on a leveling stool at a distance of about 10 feet from the ALSEP Central Station, covered by a thermal shroud. The leveling stool couples the seismometers with lunar surface motion and isolates them thermally and electrically from the lunar surface. The shroud, a multilayered blanket of highly reflective surfaces, extends over a lunar surface area 5 feet in diameter, and insulates the sensor from the temperature extremes of lunar day and night to provide the controlled thermal environment required for proper operation.

The top of the thermal shroud serves as a platform for the instrumentation used by the astronauts in initial experiment orientation. A 5-degree bubble level mounted near the center of the shroud provides a 1-degree leveling capability. A central spring-mounted gnomon and a 360-degree compass rose, designed to accommodate a variety of potential deployment sun angles, are mounted on the top periphery of the shroud and enable the astronaut to read the sun-shadow line to within ± 1 degree. Leveling-status and sun-shadow data are required to establish the orientation of the seismometers within the sensor with respect to lunar coordinates, so that variations in signals received by the horizontal seismometers can be properly compared and analyzed.

The physical parameters of the Passive Seismic Experiment are listed in Table 2. The power requirements are listed in Table 3.

2.4.2 GENERAL DESIGN CONSTRAINTS

The nature of the Apollo mission imposed unique constraints on the design, manufacture, and test of the PSE. Volume and weight were the initial major problems. A typical long-period single-axis seismometer weighs approximately 65 pounds and occupies 5000 cubic inches; the entire lunar sensor assembly, including the four seismometers, weighs 18 pounds and occupies a volume of 700 cubic inches. The weight and volume reductions were achieved in a number of ways, notable among them the use of beryllium throughout the sensor, both as a structural member and as a seismometer element.

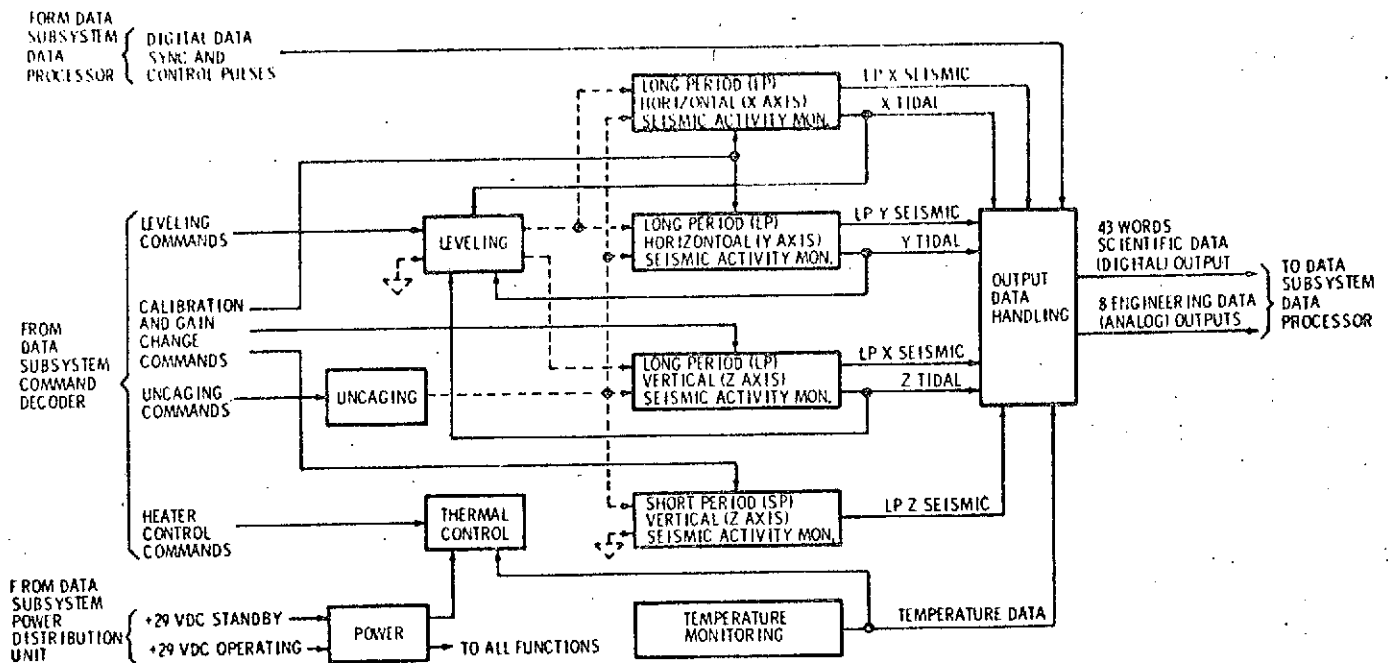

Figure 10 Passive Seismic Experiment, Functional Block Diagram

Table 2 PSE Physical Parameters

Component	Parameter	
	Weight, pounds	Dimensions, inches
Sensor	18.0	11.1 x 9.1 (diameter)
Shroud	3.6	15 x 11 (diameter)
Central Station Electronics	4.2	7.25 x 6.50 x 2.75
Leveling Stool	0.4	2.3 x 11 (diameter)

Table 3 PSE Power Requirements

Functional Mode	Power, watts
Standby	3.5
Basic Operation	4.2
Thermal Control	5.0 (maximum)
Leveling	3.0 (per axis)

Other design constraints were imposed by the remoteness of seismometer operation. The delicate suspension system of a seismometer is normally adjusted intermittently following installation to maintain the degree of tuning desired. The PSE seismometers must be adjusted either prior to launch or by command from earth following deployment. A total of fifteen commands can be transmitted to the experiment for purposes of calibrating the seismometers, altering amplifier gain, driving the leveling platform on which the long-period seismometers are mounted, raising and lowering the point from which the long-period vertical seismometer is suspended, altering the operating mode of the sensor assembly thermal control heater, and uncaging or freeing the seismometers for operation.

The requirement that the experiment be deployable by a spacesuited astronaut within a 5- to 6-minute time period imposed further constraints on PSE design.

The severe launch and lunar-temperature environments also imposed unique constraints. To protect these delicate, finely adjusted instruments during launch, the four seismometers and their suspension systems are caged by pneumatic bellows assemblies, which, locked together, can be released by a command from earth. Once on the moon, the long-period seismometers, which are highly sensitive to temperature variations, require a degree of thermal control well beyond the capabilities of standard space thermal-control systems for proper operation in a lunar-temperature environment ranging from -300°F to $+250^{\circ}\text{F}$.

The lower gravitation force on the lunar surface posed a final design and testing problem. The necessity for functional testing on earth and operability on the moon required that seismometer mass, an extremely critical parameter, be adjustable. The adjustment was made by removing 0.625 kilogram of mass for earth testing.

2.4.3 SENSOR ASSEMBLY

The long-period triaxial seismometers are mounted on a gimballed platform. The gimbal ring containing the gimballed platform is mounted in the sensor base by two flexural pivots that extend outward from the ring to the base. Mounting points for the platform itself are provided by a second pair of flexural pivots, displaced by 90 degrees, that extend inward from the ring. These flexural pivots serve as mechanical interface points for the gimbal ring, which must transmit seismic signals, and they are capable of the axial rotation that is necessary for leveling the seismometers.

Leveling of the horizontal-axis (X- and Y-axis) seismometers is accomplished by means of two leveling drive assemblies. One permits adjustment of gimbal ring position relative to the base; the other permits adjustment of platform position relative to the gimbal ring.

The sensor base provides a mounting surface for the short-period seismometer, four individual electronics boards, the sensor heaters and sensors, and the uncage mechanism assembly. The lower hemisphere of the base is round to permit uniform rotation within the leveling stool. Four legs attached to the base serve to secure the instrument to the ALSEP pallet, to secure the thermal shroud assembly to the sensor, and to interconnect with the universal handling tool, permitting the astronaut to carry the instrument to the leveling stool during lunar deployment.

2.4.4 THERMAL CONTROL

The thermal control system for the PSE includes both active and passive elements. The active element is a 5-watt proportional heater within the sensor. The passive elements are the thermal shroud and the surface finishes of the sensor. The system is designed to maintain a nominal operating temperature of $126 \pm 18^{\circ}\text{F}$;

the design goal, which must be approached if the tidal science data are to be fully utilized, is a control range of $\pm 0.38^{\circ}\text{F}$.

2.5 ACTIVE SEISMIC EXPERIMENT (ASE)

The scientific objective of the ASE is to determine the physical properties of lunar near-surface materials. Seismic energy is artificially produced by a thumper assembly and by explosive grenades, transmitted through the lunar surface materials, and measured by miniature seismometers (geophones); the detected wave trains (in the 3- to 250-hertz range) are telemetered to earth for interpretation. The ASE is also used, for short periods of time, to monitor natural lunar seismic waves in the same frequency range.

The basic scientific requirements for the ASE were developed under the direction of Principal Investigator R. L. Kovach (Department of Geophysics, Stanford University) and Co-Principal Investigator J. Watkins (Department of Geology, University of North Carolina).

2.5.1 EXPERIMENT DESCRIPTION

The astronauts deploy a line of geophones at intervals of 10, 160, and 310 feet from the ALSEP Central Station. The astronaut walks back along the deployed geophone line, using a thumper assembly to induce seismic energy into the lunar soil. The thumper contains 21 Apollo standard initiators (ASI's), which are fired by the astronaut at 15-foot intervals marked along the 300 feet of geophone line. A mortar package assembly is emplaced by the astronaut so that its firing line is 180 degrees from the deployed geophone line. Seismic energy is produced by launching four rocket-propelled, explosive grenades to lunar ranges of 500, 1000, 3000, and 5000 feet. The grenades contain 0.1-, 0.3-, 0.6-, and 1.0-pound of high explosive, respectively.

The velocity of the seismic waves can be determined by analysis of the time interval between the energy (explosion) instant and the detection of the seismic-wave arrivals. In the thumper mode, the range determination is based on a knowledge of the marked interval on the geophone cable at which the astronaut fires the ASI. The instant of ASI initiation is detected by a pressure switch and telemetered as a real-time event (RTE). In the grenade mode, the range determination is based on the parameters of a ballistic trajectory assumed to be ideal. The launch angle of the grenade is determined from measurements made of the pitch and roll angles of the mortar package prior to each launch. Initial velocity data are provided by range-line breakwire circuits, which are broken at the beginning and at the end of a 25-foot interval of line deployed at launch, the breaks being telemetered as real-time events. Time of flight is furnished by a transmitter in each grenade which is activated at launch and destroyed upon explosive impact; loss of the transmitter signal occurs at the instant of explosion and is also telemetered as a real-time event. Using these parameters (launch angle, velocity, and time of flight), grenade range can be determined to within ± 5 percent. The time of thumper ASI initiation and the time of grenade detonation are known to within ± 0.1 millisecond.

The seismic detectors are three identical geophones which are electromagnetic transducers that translate high-frequency seismic energy into electric signals. The outputs of the three geophones are applied to separate logarithmic compression amplifiers to obtain maximum dynamic range and maximum sensitivity.

The ASE uses seven commands transmitted from the Manned Space Flight Network to arm and fire the grenades and to effect geophone calibration. Other commands are used to effect power distribution to the ASE from the ALSEP data subsystem, and to place the data subsystem in the active seismic mode. The seismic data generated by the ASE, along with engineering data, are converted to digital form within the experiment. Figure 11 is a functional block diagram of the PSE. A 20-bit digital word format and a 10,600-bit-per-second data rate are used in the ASE to ensure accurate encoding and transmission of critical real-time-event data and to provide a relatively high frequency seismic-data-handling capability. The higher bit rate and the longer word length are incompatible with the normal ALSEP format and preclude the usual data collection from other experiments during the time the ASE is activated. Five significant measurements from the ALSEP electric power subsystem are included in the ASE telemetry format as engineering data. The experiment formats the seismic and engineering data and applies them to the data subsystem for modulation and down-link transmission.

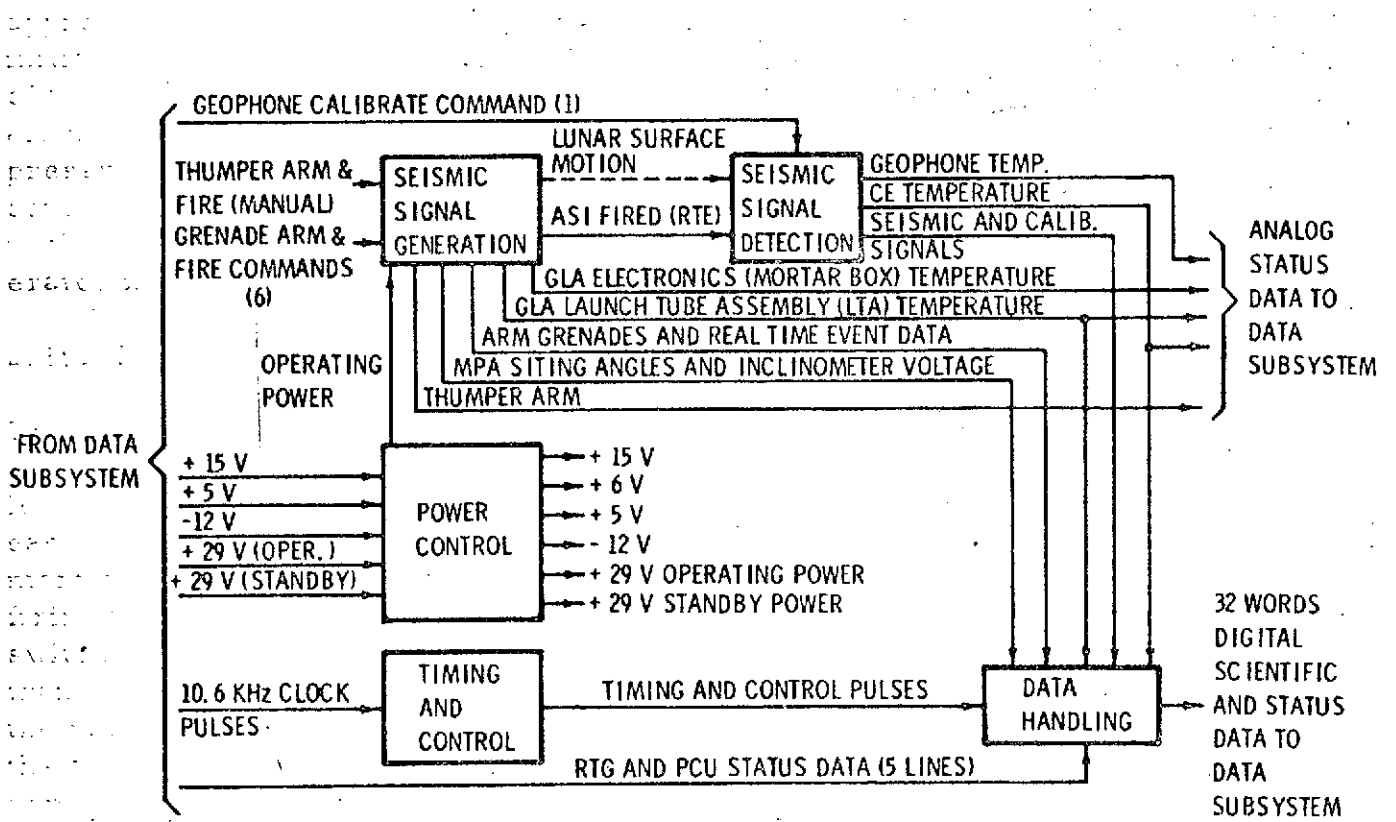

Figure 11 Active Seismic Experiment, Functional Block Diagram

2.5.2 EXPERIMENT DESIGN

The ASE is made up of three major subsystems: the thumper/geophone assembly, the mortar package assembly, and the Central Station electronics. The experiment weighs 34.66 pounds. Size and weight data for each of the subsystems are presented in Table 4 and power requirements are listed in Table 5.

2.5.2.1 THUMPER/GEOPHONE ASSEMBLY

The thumper/geophone assembly is constructed almost entirely of magnesium alloy and is so designed that it folds into three sections for stowage. It is electrically connected to the ALSEP Central Station by 318 feet of flat, four-conductor, H-film cable, which is stowed on a split spool on the upper end of the thumper handle, and unwound by the astronaut during deployment. Also stowed on the thumper until deployment are the three geophones, the geophone cabling, and an aluminum-alloy geophone flag. The geophone cabling is wound on a reel at the lower end of the thumper. The geophones are mounted in individual stowage sockets in the reel assembly and held in by removable clips. The geophone flag is similarly stowed in a socket in the reel assembly and is deployed at the second geophone emplacement to aid the astronaut in the visual alignment of the geophones.

The thumper contains 21 Apollo standard initiators (ASI's), rated at 1 ampere "no fire" and 3 amperes "all-fire". Each ASI, when fired, generates a pressure of approximately 650 pounds per square inch in a 10-cubic-centimeter volume. The initiators are threaded into a magnesium mounting plate, which forms a portion of the thumper base. The ASI's are individually fired directly into a forged-aluminum impact plate, which is spring-loaded against the mounting plate. The gas pressure resulting from an initiator discharge drives the impact plate sharply downward, imparting a thump to the lunar surface. A pressure switch, installed in the mounting plate, is closed by the pressure, which causes a signal to be generated in the ASE central electronics, indicating the instant of explosion.

2.5.2.2 MORTAR PACKAGE ASSEMBLY (MPA)

The MPA consists of a mortar box assembly and a grenade launch assembly (GLA). The mortar box is an L-shaped fiberglass box, with a magnesium frame and folding legs. The grenade launch assembly is made up of four fiberglass launch tubes, each containing a rocket-launched explosive grenade. The GLA is mounted in the mortar box. The mortar box contains the electronic circuitry for arming and firing the grenade rocket motors, along with a receiving antenna, two SAFE/ARM switches, and a thermal bag. The antenna, used in conjunction with the grenade transmitters, is mounted to the side of the mortar box and folded along the edge of the package during transport. A flag is mounted on the antenna top section to aid the astronaut during deployment. The two SAFE/ARM switches disable both the arming and the firing circuits and short out the rocket-motor firing capacitors and initiators for astronaut safety during lunar deployment.

Table 4 ASE Parameters

Subsystem or Component	Parameter	Value
Thumper/Geophone Assembly	Length (folded)	14.5 inches
	Weight	7.59 pounds
Thumper	Length (deployed)	44.5 inches
	Weight (incl. cables and initiators)	4.64 pounds
Geophones	Height (including spike)	4.80 inches
	Diameter	1.66 inches
	Weight (3 geophones with cables)	2.95 pounds
Mortar Package	Envelope Height	11.5 inches
	Envelope Width	6.0 inches
	Envelope Length	15.25 inches
	Weight	17.00 pounds
Mortar Box Assembly	Height	11.5 inches
	Width	6.0 inches
	Length	15.25 inches
	Weight (incl. antenna and cables)	6.39 pounds
Grenade Launch Assembly	Width	9.0 inches
	Length	13.7 inches
	Depth	6.23 inches
	Weight (including grenades)	10.88 pounds
Grenades	Cross Section	2.7 inches
	Length	4.6 inches
	Weight* (total)	8.08 pounds
Central Electronics Assembly	Height	2.75 inches
	Width	6.18 inches
	Length	6.77 inches
	Weight	3.22 pounds
Mortar Package Pallet Assembly	Width	24.0 inches
	Length	26.0 inches
	Weight	6.85 pounds

* Grenades 1, 2, 3, and 4 weigh 2.67, 2.19, 1.70, and 1.52 pounds, respectively.

Table 5 ASE Power Requirements

Type	Amount
Voltage	
ASE-Activated	+20, +15, -12, and +5 volts d. c.
ASE-Deactivated	+29 volts d. c.
Power	
Operational	8.0 watts (maximum) 6.0 watts (nominal)
Thermal Control (standby)	3.00 watts

In the deployed position the MPA is supported by two legs, which are stored along the side of the box during transport and folded down and locked into place during deployment. The mortar box is attached to an aluminum-skin pallet assembly in the final deployed configuration. The pallet has four 7-inch stakes mounted to its underside and, when placed on the lunar surface, provides a stable base for a 45-degree grenade launch.

The MPA is designed to survive on the lunar surface for a period of one year. A temperature range between -60°C during lunar night and $+85^{\circ}\text{C}$ during lunar day is maintained by a thermal control design incorporating thermal isolation and insulation as well as electronic heaters inside the mortar box. Isolation is provided by a multilayer aluminized-Mylar thermal bag, which is installed inside the mortar box. The electronic heaters are mounted on the walls of this bag. Insulation is provided by a multilayer aluminized-Mylar fiberglass cover along the top of the mortar box. This cover remains in place throughout lunar storage until the first grenade is launched through it; it also serves as a radio-frequency-interference shield, completely enclosing the GLA.

2.6 CHARGED-PARTICLE LUNAR ENVIRONMENT EXPERIMENT (CPLEE)

The CPLEE was designed to measure electron and proton fluxes at the lunar surface resulting from solar wind, thermalized solar wind, cosmic rays from solar flares, and charged-particle clouds formed and trapped in the earth's magnetospheric tail. The characteristics measured include particle energies in the 40- to 70,000-electron-volt range, as well as angular distributions and time variations. The measurements are expected to provide information on a variety of particle phenomena to shed light on such matters as the origin of aurorae.

The CPLEE was conceived in 1965 by Principal Investigator Brian J. O'Brien, then associated with the Space Science Department at Rice University. The experiment is similar in concept and purpose to a series of experiments designed for satellite and rocket payloads to investigate causes and characteristics of auroral phenomena. The Co-Principal Investigator is David L. Reasoner of Rice University.

The CPLEE was designed and fabricated at the Bendix Research Laboratories, Southfield, Michigan, under contract to Bendix Aerospace Systems Division.

2.6.1 EXPERIMENT CONCEPT

The CPLEE is a remote particle-flux measurement system incorporating sensors and electronics in a deployable package. The package provides mechanical integrity during Apollo launch and protects the experiment subsystems on the lunar surface from the effects of solar radiation.

The experiment instrumentation includes two identical electron/proton energy analyzers, one oriented vertical to the lunar surface and the other positioned to monitor particle fluxes from lunar east at an angle 60 degrees from vertical. Mounted below the analyzers are power supplies for the analyzers, pulse-counting circuitry for counting the electrons and protons at each of 18 energy levels over selected time intervals, and electronics for binary-encoding the flux data and for transferring them to the ALSEP data subsystem for transmission to earth. Figure 12 is a functional block diagram of the CPLEE.

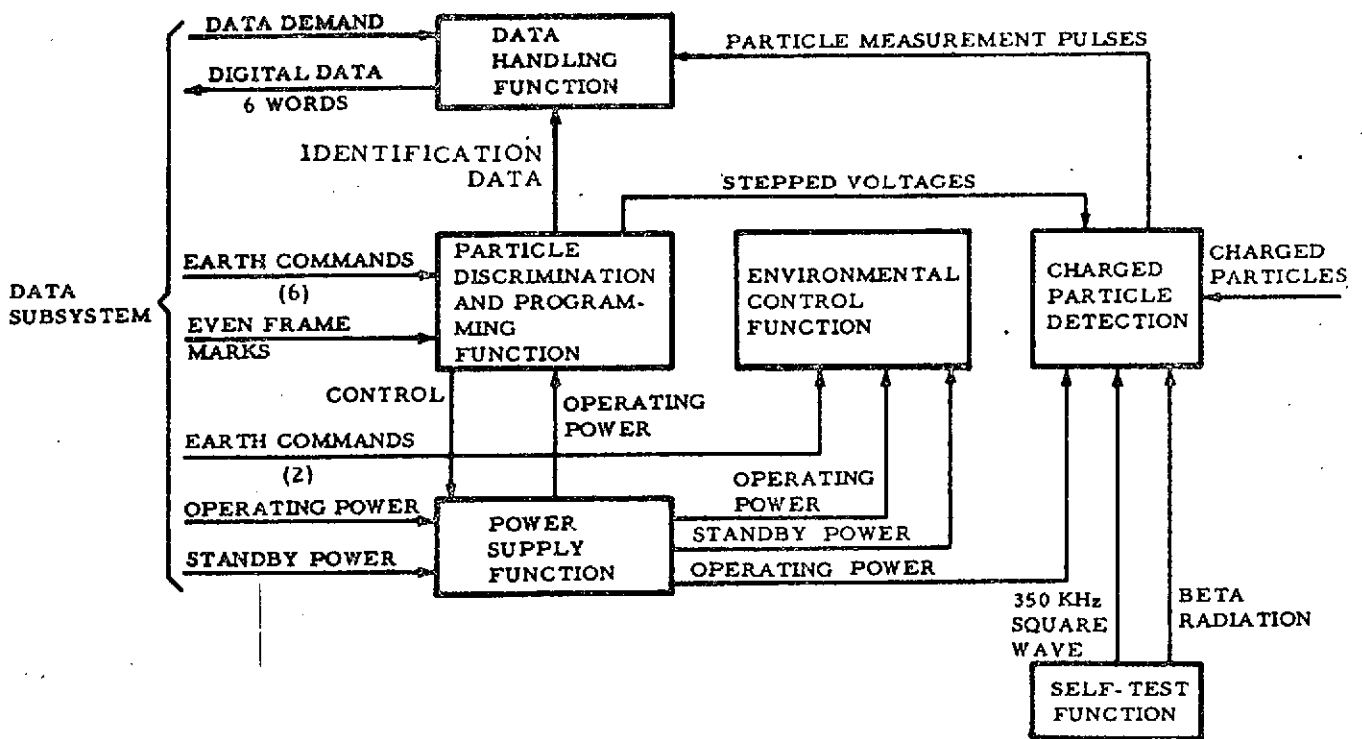

Figure 12 Charged Particle Lunar Environment Experiment, Functional Block Diagram

Electrons and protons of all energies enter the analyzers through a three-aperture collimating slit system with a look angle of 4 degrees by 20 degrees. The charged particles pass between a pair of electrostatic deflection plates and are dispersed, the amount of dispersion depending on the particle energy, charge sign, and voltage on the deflection plates. With the lower deflection plate grounded and the upper plate stepped through eight voltage levels (three positive levels, zero, three

negative levels, and back to zero), proton and electron energies are sorted into 18 different bands. Sensors are calibrated and background measurements are made while the deflection plate is passing through the two zero-voltage levels in each complete energy-scanning cycle. With a deflection-plate dwell of approximately 2.4 seconds at each voltage level, and with the two analyzers alternately collecting data and reading out data into the ALSEP data subsystem, a complete analysis of electrons and protons occurs every 20 seconds.

To ensure the operational capability of the CPLEE in the extreme temperature environments of both lunar day and lunar night, careful attention was given to the structural/thermal design of the experiment. The CPLEE detectors and electronics can operate safely over the temperature range -40°F to $+160^{\circ}\text{F}$, dissipating 5 watts of power during operation; it was necessary, therefore, to balance such thermal processes as surface reflection and reradiation, insulation, and thermal conduction to maintain the required operating temperature range.

The materials used in the CPLEE were selected for their low weight, their high structural stability, and their low outgassing rate in the vacuum radiation environment of the moon. Since the open-window Channeltron detectors must operate in a vacuum below 10^{-5} Torr, materials with high outgassing rates could not be tolerated. Also enforcing this constraint was the fact that ± 3500 volts are applied to the deflection plates and $+300$ volts are applied to the Channeltron detectors; leakage currents at pressures above 10^{-5} Torr can contribute to background noise, and high current discharges could damage power supplies and detectors.

Very tight mechanical tolerances were imposed on the components of the analyzer assemblies by the need for a high degree of energy-band repeatability for individual detectors from one analyzer to another, with calibration limited to pre-launch exercising of the experiment.

2.6.2 DESIGN REQUIREMENTS

The primary design requirements for each sensor assembly are detailed in Table 6. ALSEP system requirements limited maximum operating power for the instrument to 3.0 watts (plus 3.5 watts for active thermal control), and Apollo mission requirements limited its weight to 6.0 pounds. Thermal design requirements imposed severe constraints on instrument design, which had to minimize loss of internal heat under lunar night conditions, and at the same time provide efficient dissipation of electrically generated heat plus reflection of solar radiation during lunar day.

2.7 LUNAR HEAT FLOW EXPERIMENT (HFE)

The HFE was developed to perform lunar subsurface measurements from which local heat flow can be derived. The flow of heat from the lunar surface, and the associated subsurface temperature fields, have evolved from the conditions that existed when the moon was formed. A knowledge of the present level of surface heat flow may place some important limits on the range of feasible lunar models.

Table 6 CPLEE Design Requirements

Parameter	Requirement
Field of View	4 degrees by 20 degrees.
Particle Energy Range	40 electron volts to 70 kiloelectron volts
Maximum Detectable Flux C-Type Channeltron	10^{10} particles per square centimeter per second per steradian.
Funnel-Type Channeltron	8×10^8 particles per square centimeter per second per steradian.
Minimum Detectable Flux C-Type Channeltron	10^5 particles per square centimeter per second per steradian.
Funnel-Type Channeltron	8×10^3 particles per square centimeter per second per steradian.
Count Rate	400,000 particles per second with a pulse-pair resolution of 1 microsecond.
Cross Talk between Channels	Not more than 10 counts per second (with detector aperture covered) when adjacent channel is counting 500,000 parts per second.
Ultraviolet Rejection	10 counts in any channel when entrance aperture is irradiated with 5.1 ergs of ultraviolet radiation at 1216 angstroms.

The average absolute temperature at any point in the subsurface (regolith) results from the balance between the solar heat influx and the total heat outflow acting through the regolith. Two different approaches are used in measuring lunar subsurface thermal conductivity. In the first approach, the thermal response of lunar material to known heat sources is tested. In the second, vertical strings of temperature sensors record the characteristics of the periodic propagations into the surface to determine diffusivity; with this diffusivity information and good estimates of soil mass density and specific heat, thermal conductivity can be calculated.

Principal Investigator for the HFE is Marcus G. Langseth, Jr., Lamont-Doherty Geological Observatory, Columbia University, Palisades, New York. Co-investigators are John Chute, Jr., Lamont-Doherty Geological Observatory, and Sidney P. Clark, Jr., Yale University, New Haven, Connecticut.

Aerospace Systems Division of the Bendix Corporation had overall responsibility for hardware development and integration. Arthur D. Little, Inc., Cambridge, Massachusetts, built the heat-flow probes and the probe test apparatus. Culton

Industries, Albuquerque, New Mexico, built the heat-flow electronics. Rosemount Engineering Company, Minneapolis, Minnesota, produced the sensors.

2.7.1 EXPERIMENT DESCRIPTION

In deployment, the Apollo Lunar Surface Drill is used to drill two hollow fiberglass borestems, 2.5 centimeters in diameter, into the lunar surface to a depth of 3 meters at a distance of 10 meters from one another. A probe assembly consisting of four sets of temperature sensors, spaced along two flexibly joined rigid sections, is deployed in the bottom meter of each hole. The flexible joint permits the probe to be folded for transportation to the moon. The sensors, which are primarily radiatively coupled to the borestem and lunar soil, are connected electrically by 8-meter woven cables to a package of electronics on the surface. Each cable carries four precisely located thermocouple junctions in the borestems above the probes. The electronics unit is connected by a flat ribbon cable, 9 meters long, to the ALSEP Central Station.

The heat-flow instrument returns data giving average-temperature, differential-temperature, and low- and high-thermal-conductivity information from four locations on each probe, with the thermocouples supplying readings for temperature determinations in the upper part of the boreholes. Instrument performance requirements for these measurements are summarized in Table 7. In the normal operating mode, the heat-flow instrument gathers ambient and high- and low-sensitivity differential temperature data from the "gradient" sensors situated at the ends of each half-probe section, and samples the thermocouple outputs during the 7.25-minute measurement sequence. Various subsequences can be selected. Low-conductivity experiments are performed on command, with each heater activated in turn to 0.002 watt for about 40 hours. The normal measurement sequence is unchanged. The high-conductivity mode of operation requires the selection of measurements on the remote sensors in any half-probe section, the type of data returned alternating between high-sensitivity differential and absolute temperature measurements. Either of the adjacent heaters at the ends of the probe half may be activated by command. Each heater should be on for about 6 hours. Figure 13 is a functional block diagram of the experiment.

The experiment data require detailed analysis - including processing through finite-difference models of the thermal transfer functions relating lunar soil, heaters, and sensors - before they can be interpreted in a geophysical context to produce a single value for the heat-flow rate from the moon.

2.7.2 CONSTRUCTION AND THERMAL CONTROL

The heat-flow instrument operates from a 29-volt d. c. supply and requires data-interlace and mode-control signals from the ALSEP Central Station. The unit is otherwise self-contained with respect to logic and power management for all the sensor measurements and for probe-heater control. A ribbon cable made up of 40 flat copper conductors in a plastic film connects the instrument package to the ALSEP Central Station.

Table 7 HFE Performance Requirements

Measurement	Requirement			
	Range	Resolution	Accuracy ^a	Minimum Stability
Temperature Difference across 0.5-Meter Probe Section in Lowest Meter of Hole	$\pm 2^{\circ}\text{K}$ (high sensitivity) $\pm 20^{\circ}\text{K}$ (low sensitivity)	0.0005°K (high sensitivity) 0.005°K (low sensitivity)	$\pm 0.003^{\circ}\text{K}$	$0.003^{\circ}\text{K}/\text{year}$
Ambient Temperature of Probe in Lowest Meter of Hole	200-250 $^{\circ}\text{K}$	0.02-0.08 $^{\circ}\text{K}$	$\pm 0.1^{\circ}\text{K}$	0.05 $^{\circ}\text{K}/\text{year}$
Temperature of Thermo-couples in Upper 2 Meters of Hole	90-350 $^{\circ}\text{K}$	$\pm 0.17^{\circ}\text{K}$	$\pm 0.5^{\circ}\text{K}$	0.5 $^{\circ}\text{K}/\text{year}$
Thermal Conductivity of Material Surrounding Probes	0.002-0.4 watt/meter $^{\circ}\text{K}$	$\pm 20\%$	$\pm 20\%$	

^a Maximum probable error.

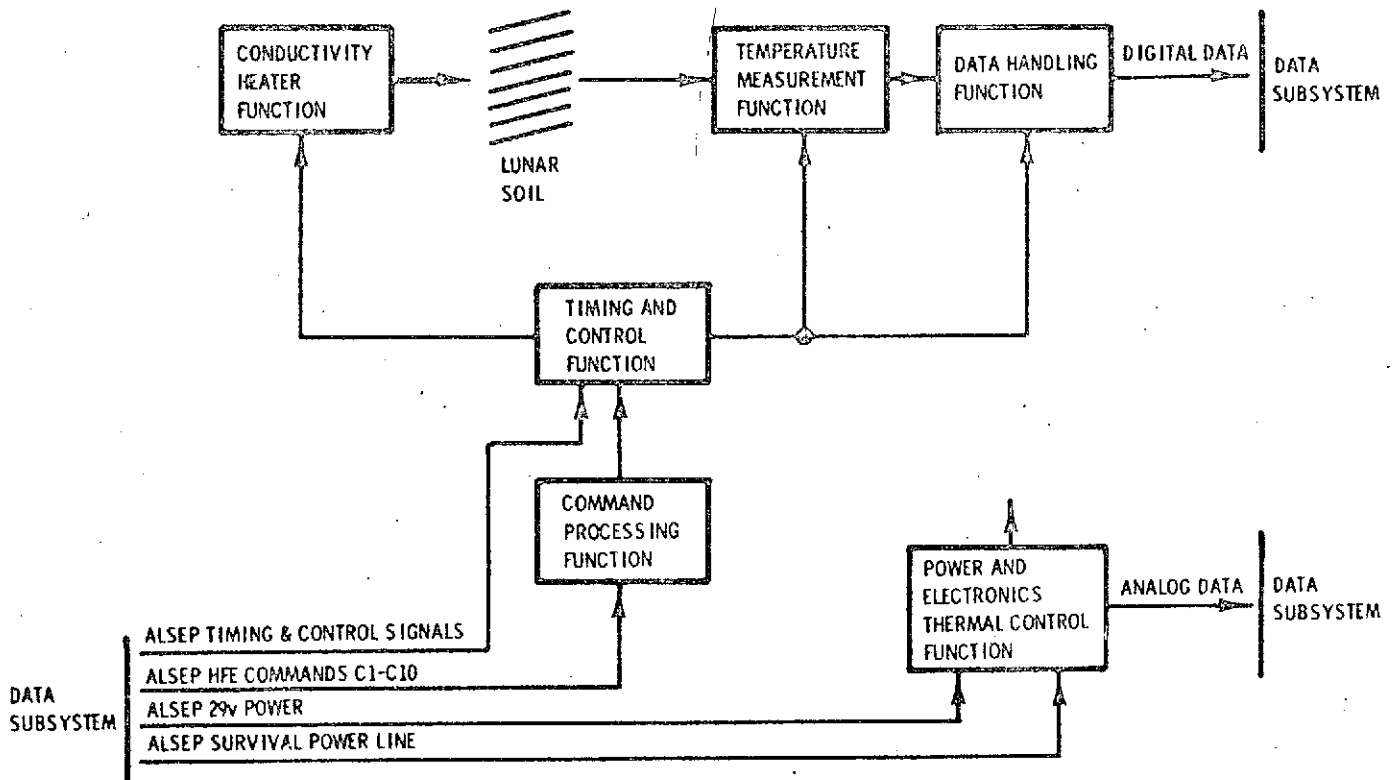

Figure 13 Heat Flow Experiment, Functional Block Diagram

The two probe cables are each made up of 35 unshielded conductors, interwoven for a uniform stress distribution. These cables are very flexible, exhibiting little residual torque when extended, and they are covered with a woven Teflon sleeve to provide a low coefficient of friction during deployment. Heat leaks from the cables on the lunar surface to the probes and the electronics package are small since the conductors are made from low-thermal-conductivity wire.

The complete package weighs 7.0 pounds (3.2 kilograms) and is 9.5 x 10.0 x 11.0 inches (24 x 25 x 28 centimeters) in size, including the feet. The astromate connector, ribbon cable, and spool weigh 1.4 pounds (0.6 kilogram).

The thermal control design to meet the required electronics temperature operating range of 278°K to 328°K was dictated largely by the power dissipation of the unit at lunar noon. The average dissipation was minimized by gating off as many circuits as possible when they are not required for measurements. During power gating, the average operational power dissipation is 3.9 watts. The power-sharing mode is set to switch in when thermal-plate temperature exceeds 300°K. During lunar night, when the electronics temperature falls below 290°K, additional power is dissipated by the heaters on the thermal control plate. The total power demanded by the instrument at lunar night is 10.5 watts. Should the 29-volt operational supply be switched off under abnormal circumstances, a separate survival line can be activated to a part of the thermal-plate heater for a power dissipation of 4 watts.

A thermal insulation bag, shaped as a container for the metal cover surrounding the electronics is hooked by velcro pads to a low-thermal-conductivity mounting ring fitted around the inside edge of the thermal plate.

The electronics assembly is supported and protected by a thin fiberglass outer case, which is connected to the mounting ring by low-conductivity joints. When the unit is standing on the feet of this outer case, the well-insulated electronics compartment is situated beneath the exposed thermal control plate. Internally generated heat is conducted to the plate and radiated from a spectrally selective surface coating (S-13G) having a high infrared emittance and a low absorptance at frequencies where solar power is most intense.

The thermal plate is protected from direct solar radiation by a sunshield fitted over the assembly. The sunshield is an insulated box with one open side, which is placed to face away from the equator with its edge aligned in the east/west direction. Numbered marks on the sunshield are used as a shadowgraph with the shadow cast by the universal handling tool. A specular reflector slopes from the top edge of the sunshield at an angle 57 degrees from vertical to almost touch the thermal plate. Side curtains adjoining the sloping reflector are also specular surfaces. The back of the reflector and the thermal control plate inside the sunshield are heavily blanketed with aluminized Mylar, layered in the same way as in the thermal bag. The exterior surfaces of the entire package are covered with S-13G thermal control coating.

A mask of multilayer insulation is attached to the edge of the thermal plate to prevent direct sunlight from reaching it in the event of moderate misalignment from an east/west line or instrument leveling error.

The probes are folded, with two molded packing pieces secured by nylon cloth and velcro pads holding the sections slightly apart. They are stored for transportation in two aluminum containers, which are carried to separate deployment sites on the lunar surface, each with one probe inside. The probes are held within the containers in nylon bags by soft foam bulkheads. The cables are coiled around the inside of the probe containers in troughs formed by an inner wall on each side. One probe container has provision for stowing the collapsed probe emplacement tool. The tool is white, with alphanumeric markings at 2-centimeter intervals, and a bright orange band to indicate the depth to which the probe should be positioned.

The two probe containers fit together to form a single package which is covered with white thermal-control paint and secured by velcro straps with pull rings. A complete probe-container assembly is 3.4 x 4.5 x 25.5 inches (8.6 x 11.4 x 64.8 centimeters) in size, excluding handles, and weighs 3.5 pounds (1.6 kilograms).

A nylon cover on the electronics package, which serves to protect the thermal control surfaces from lunar dust, is removed before final leveling and alignment of the instrument on the moon.

2.8 GOVERNMENT FURNISHED EXPERIMENTS

2.8.1 LUNAR SURFACE MAGNETOMETER EXPERIMENT (LSM)

The lunar surface magnetometer experiment measures the topology of the interplanetary magnetic field diffused through the Moon to determine boundaries of the electromagnetic diffusivity. The experiment will give some indication of inhomogeneities in the lunar interior.

Data acquisition and processing, both scientific and engineering, proceeds continuously in any of the operational configurations selectable by commands from Earth.

The LSM consists of three magnetic sensors, each mounted in a sensor head and located at the ends of three-foot long support arms. The magnetic sensors, in conjunction with the sensor electronics, provide signal outputs proportional to the incident magnetic field components parallel to the respective sensor axes. Each magnetic sensor is housed in an outer structural jacket made of fiberglass. The jackets are wrapped with insulation, except for their upper flat surfaces, called thermal control surfaces, that serve as heat radiators. Although the magnetic sensors themselves are positionable, the outer jackets remain stationary throughout LSM operation. The sensors and their jacket housings are supported at equal distances above the lunar surface and apart from each other by the three fiberglass support arms.

2.8.2 SUPRATHERMAL ION DETECTOR EXPERIMENT (SIDE)

The suprathermal ion detector experiment (SIDE) comprises the suprathermal ion detector and the cold cathode ion gauge (CCIG). The purpose of the experiment is to measure the ionic environment of the Moon by detecting the ions resulting from the ultra-violet ionization of the lunar atmosphere and the free streaming and thermalized solar wind. The suprathermal ion detector will measure the flux, number density, velocity, and energy per unit charge of positive ions in the vicinity of the lunar surface. The cold cathode ion gauge will measure the density of any lunar ambient atmosphere, including temporal variations either of a random character or associated with lunar local time or solar activity. In addition, the rate of loss of contaminants left in the landing area by the astronauts and lunar module will be measured.

The suprathermal ion detector experiment consists of a velocity filter, a log energy curved plate analyzer ion detector, a high energy curved plate analyzer ion detector, a cold cathode ion gauge, a wire mesh ground plane, and associated electronics.

2.8.3 SOLAR WIND SPECTROMETER (SWS)

The Solar Wind Spectrometer subsystem will measure energies, densities, incidence angles, and temporal variations of the electron and proton components of the solar wind plasma that strikes the surface of the Moon.

The experiment will yield data that will be utilized to expand knowledge in the following scientific areas:

- a. The existence of solar wind at the lunar surface.
- b. The general properties of the solar wind.
- c. The properties of the magnetospheric tail of the Earth.

The SWS output signal is a serial, non-return-to-zero digital train that is accepted by the data subsystem at the rate of four words per ALSEP telemetry frame. A complete SWS measurement cycle is organized into 16 sequences of 186 ten-bit words. Each word of each sequence contains a specific element of data. The words are identified within the sequence by the first two bits of the word and the sequence is identified by the least significant bits of the 185th word of the sequence. Of the 186 words in each sequence, 112 words contain positive particle measurement data, 56 words contain negative particle measurement data, 16 words contain SWS calibration and operation data, and two words contain sequence and cycle identification data.

The SWS consists of four major assemblies: sensor, leg assemblies, electronics, and thermal control. A 20-conductor flat cable provides electrical connection between the SWS and the ALSEP data subsystem, and allows them to be separated by 14 feet. The cable is housed in a reel which is stowed beneath the SWS.

2.8.4 COLD CATHODE GAUGE EXPERIMENT (CCGE)

The cold cathode gauge experiment (CCGE) will measure the density of ambient lunar atmosphere, including any temporal variations either of a random character or associated with lunar local time or solar activity. In addition, the rate of loss of contaminants left in the landing area by the astronauts and lunar module will be measured.

Five command lines provide measurement ranging and calibration control through the data subsystem. The CCGE reports digital scientific data to the data subsystem in five words of each ALSEP telemetry frame, and two analog status (sensor temperature and sensor output) measurements which are subcommutated in word 33 of the telemetry frame.

The cold cathode gauge experiment consists of a cold cathode ion gauge assembly (CCIG), electronics package, and structural and thermal housings.

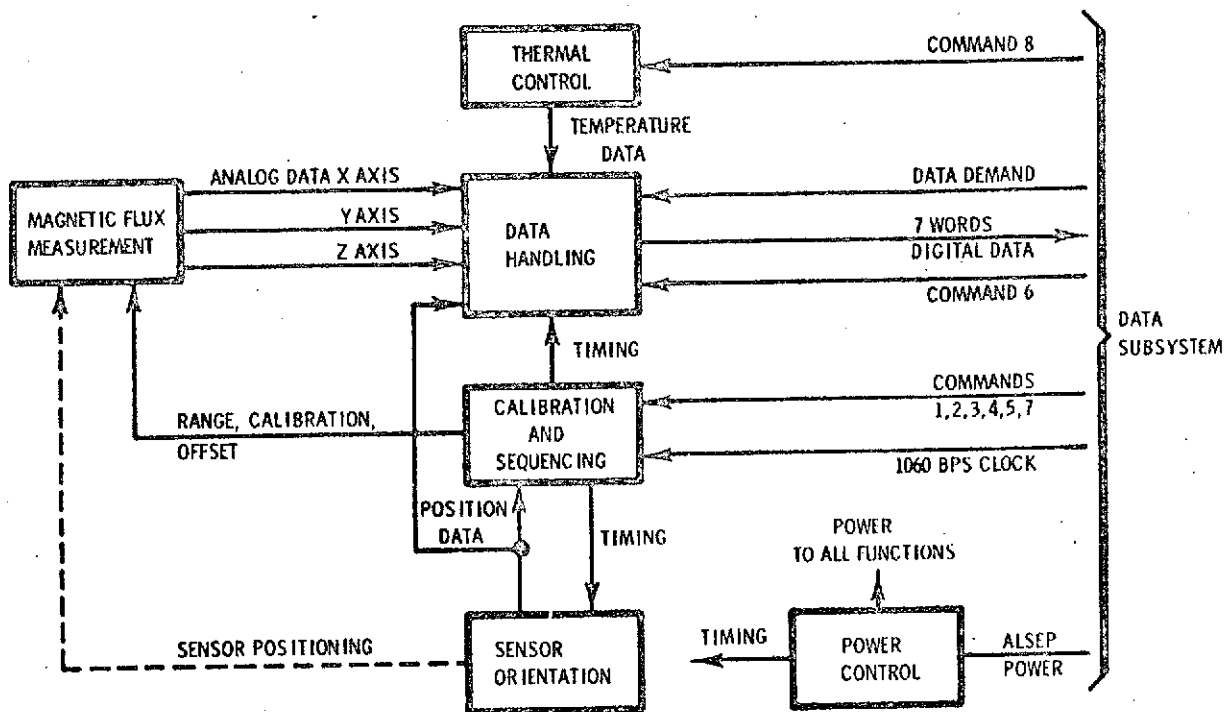

Figure 2.8-1 Magnetometer Experiment, Functional Block Diagram

respective axes. All sensors have the capability to sense over any one of three dynamic ranges:

- a. Range 1 -100 to +100 gamma
- b. Range 2 -200 to +200 gamma
- c. Range 3 -400 to +400 gamma

The range is selected by Earth command during experiment operation. The housekeeping function provides:

- a. Data describing the condition of the subsystem.
- b. Status data defining the operational state to permit proper interpretation of the scientific data.
- c. Orientation data to permit referencing the vector magnetic field data to lunar coordinates.

- d. Monitoring of temperatures by five sensors.
- e. Monitoring of the +5V reference supply for magnetic field measurement calibration check.

The sensor orientation function monitors both the leveling of the experiment and the position of the magnetic sensors and performs the electromechanical flip and gimbal of the magnetic sensors controlled by Earth command during LSM operation.

The calibration and sequencing function receives and interprets Earth commands to calibrate and sequence the operation of the other LSM functions.

The data handling function receives analog voltages from the electromagnetic measurement and housekeeping function, and processes this analog data into digital format to satisfy ALSEP telemetry requirements. The data handling function then stores this information until the data subsystem requests it.

The thermal control function maintains the required thermal operating environment for the experiment.

The power control function comprises a dc/dc converter and system timer that provide regulated output voltages, as required on a time-shared basis, to the LSM subsystem.

The above functions are performed in response to the eight Earth commands assigned to the experiment.

LSM Data Handling. - A functional block diagram of the LSM data handling function is shown in Figure 2.8-2. The data handling function converts scientific and engineering data into a digital format compatible with the ALSEP telemetry interface.

Scientific Data Processing. - The three pre-filtered analog outputs of the sensor electronics are sampled simultaneously (to within 125 microseconds of one another) at the digital filter sampling rate by a sample and hold circuit. The stored (analog) samples are multiplexed into the analog-to-digital converter which sequentially converts each into a 10-bit binary word that is shifted out into a memory unit in the digital filter.

The digital filter serves to reduce to an acceptable level the aliasing error introduced into the scientific data by the output data sampling rate. The

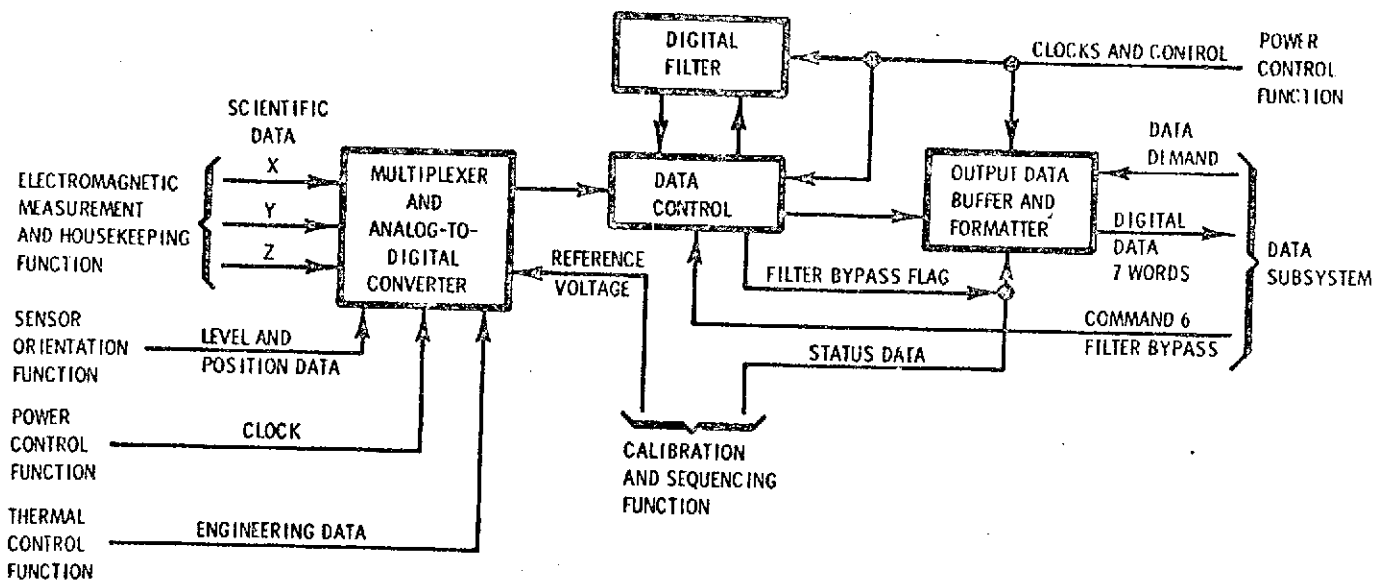

Figure 2.8-2 LSM Data Handling Function, Block Diagram

three channels of scientific data time share the arithmetic unit, the data bus, and the data control in the digital filter. The various state variables are stored in a core memory in the filter when not being used to perform a calculation. The state variable representing the filtered output of each channel at a given (real time) sample instant is shifted out into the output data subsystem upon receipt of a data demand pulse. Therefore, although the readouts to the data subsystem are staggered in time, they represent approximately simultaneous, periodic samples of the three magnetic field vector components in real time.

The digital filter may be bypassed if ordered by ground command. In this case, the scientific data undergoes only analog filtering with a resultant increase in aliasing error.

Engineering and Status Data Processing - The engineering data processing unit converts 8 channels of analog engineering data into binary form in addition to processing binary status data.

The engineering data is multiplexed with the scientific data, thus permitting the use of a single multiplexer and A/D converter. The analog engineering data is converted to 10-bit binary words by the converter but is subsequently

truncated to 7 bits, yielding a resolution of approximately ± 0.5 percent. The converted engineering data bypasses the digital filter routine and is sent to the output data buffer and formatter where it is subcommutated with the binary status data and shifted out to the data subsystem for downlink transmission as word 5 in 16 consecutive ALSEP frames.

Thermal Control Function - The LSM is designed to operate over the temperature range of -50°C to $+65^{\circ}\text{C}$. This range applies to the interior of the base package and each sensor head. Maintenance of interior temperatures within the above range in the severe lunar thermal environment is accomplished by a combination of insulation, control surfaces, parabolic reflectors, sunshades, and heaters.

2.9 SUPRATHERMAL ION DETECTOR EXPERIMENT (SIDE) (GFE)

The suprathermal ion detector experiment (SIDE) comprises the suprathermal ion detector and the cold cathode ion gauge (CCIG). The purpose of the SIDE is to measure the ionic environment of the Moon by detecting the ions resulting from the ultra-violet ionization of the lunar atmosphere and the free streaming and thermalized solar wind. The suprathermal ion detector will measure the flux, number density, velocity, and energy per unit charge of positive ions in the vicinity of the lunar surface. The cold cathode ion gauge will determine the density of any lunar ambient atmosphere, including any temporal variations either of a random character or associated with lunar local time or solar activity. In addition, the rate of loss of contaminants left in the landing area by the astronauts and lunar module (LM) will be measured.

The SIDE uses two curved plate analyzers to detect and count ions. The low-energy analyzer has a velocity filter of crossed electric and magnetic fields. The velocity filter passes ions with discrete velocities and the curved plate analyzer passes ions with discrete energy, permitting determination of mass as well as number density. The second curved plate analyzer, without a velocity filter, detects higher energy particles, as in the solar wind. The SIDE is emplaced on a wire mesh ground screen on the lunar surface and a voltage is applied between the electronics and ground plane to overcome any electrical field effects.

The SIDE will count the number of low-energy ions in selected velocity and energy intervals over a velocity range of 4×10^4 cm/sec up to 9.35×10^6 cm/sec and an energy range of 0.2 eV to 48.6 eV. The distribution of ion masses up to 120 AMU can be determined from this data. In addition, the

the electric potential between the SIDE and the local lunar surface will be controlled by applying a known voltage between the instrument and a ground plane beneath it. If local electric fields exist, they will be offset at one of the ground plane voltage steps. By accumulating ion count data at different ground plate potentials, an estimate of local electric fields and their effects on ion characteristics can be made.

In addition to low-energy ions, the SIDE will also measure the number of particles of higher energies, primarily solar wind protons. A separate detector counts the number of particles in selected energy intervals between 10 ev and 3500 ev. The mass of these particles cannot be determined because the detector does not have a velocity selector.

The CCIG will determine the pressure of the ambient lunar atmosphere by measuring the density of neutral atoms and the temperature of the gauge at the time of measurement. The CCIG measurements will also provide an indication of the effects of contaminants left by the LM and the astronauts on the lunar atmosphere and the rate of decay of these contaminants. The CCIG will measure pressures over the range of 10^{-6} torr to 10^{-12} torr.

Five command lines are provided from the ALSEP data subsystem to the SIDE/CCIG. Four of these lines are used to encode up to 15 different command functions; the fifth line provides an execute command to carry out the command encoded into the other four lines. The experiment also has the capability to carry out two, one-time commands. For example, the first time a pulse is placed on command line No. 2, it also goes to a one-time command register. When the command is executed, the corresponding one-time command is also executed. Subsequent pulses on that line do not affect the one-time command register.

Two analog data lines from the SIDE/CCIG to the ALSEP data subsystem provide the high energy curved plate analyzer (CPA) count rate and the low energy CPA count rate to the data subsystem for incorporation into ALSEP housekeeping word 33. These count rates are used as backup measurements in the event of digital counting electronics failure.

The digital scientific data from the SIDE/CCIG consists of five 10-bit words in each ALSEP telemetry frame (words 15, 31, 47, 56, and 63). A total of 10 words are used to make up the basic unit of data, which is called a SIDE frame. The experiment programmer goes through 128 steps in completing its program; this is called a cycle. The ground plane stepper steps once per cycle. The 24 cycles, which constitute the number of ground plane voltage steps, are called a field.

2.9.1 SIDE PHYSICAL DESCRIPTION

The suprathreshold ion detector experiment consists of a velocity filter, a low energy curved plate analyzer ion detector, a high energy curved plate analyzer ion detector, a cold cathode ion gauge, a wire mesh ground plane, and associated electronics.

The package structure consists of an internal chassis which mounts the electronics and ion detectors. The inner chassis is held under tension to the outer case by four tie-down points to the base, and is supported at the top by four nylon buffers in the thermal spacer. The thermal spacer reduces the solar heat input to the electronics by reflection at the second surface mirrors on its top surface and by isolating the inner chassis from the outer case. The thermal spacer also allows heat from the electronics to be radiated to space. A conductive grid network on the upper surface of the top plate provides an equipotential reference surface around the apertures to the ion detectors.

The ion detector apertures are protected during transit and LM departure by a single dust cover released, on ground command, by a solenoid operated catch. The outer case, legs, and dust covers are painted with white thermal paint which contributes to the thermal control of the experiment. Further thermal control is obtained through use of electric heaters. A bullseye leveling gauge is mounted on top of the SIDE to enable the astronaut to level the package within 5° of level during deployment. Three folding legs on the base of the chassis are extended during deployment to form a low tripod supporting the package.

The outer case houses the cold cathode ion gauge (CCIG) which is removed by the astronaut during deployment of the SIDE. The gauge is connected to the experiment by a short cable. The CCIG aperture is sealed against ingress of dirt and moisture. The seal is removed, on ground command, by an explosive actuated piston releasing a spring.

The ground plane is housed in a tube attached to the SIDE and is removed by the astronaut during deployment. The ground plane is a conductive wire mesh network placed on the lunar surface beneath the experiment to provide an equipotential reference surface for control of local electric fields between the two SIDE ion detectors and the lunar surface.

The flat tape cable connecting the experiment to the ALSEP central station is housed in a reel which is stowed at the base of the SIDE. The reel is removed and the cable deployed when deploying the experiment.

2.9.2 SIDE FUNCTIONAL DESCRIPTION

The SIDE/CCIG is divided into four major functional elements; command function, programmer function, ion detection function, and data handling function (Figure 2.9-1. In addition, a power supply function provides system power to all operational circuits and a thermal control function maintains thermal equilibrium of the experiment on the lunar surface.

The command function accepts command and execute pulses from the central station data subsystem, decodes the commands, and applies them to the programmer function or the ion detection functions as appropriate.

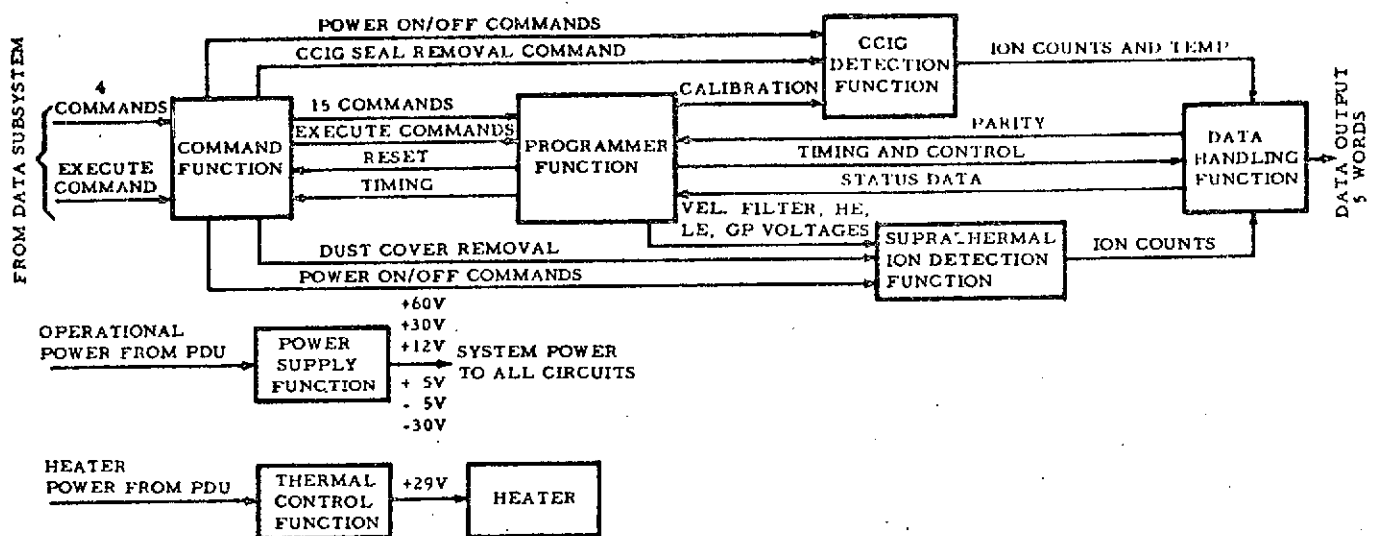

Figure 2.9-1 Suprathermal Ion Detector Experiment, Functional Block Diagram

The programmer function provides timing and control to the ion detection function and the data handling function. The voltage stepping of the high energy curved plate analyzer, low energy curved plate analyzer, velocity filter, and ground plane are controlled by the programmer function. The programmer also supplies calibration timing to the CCIG.

The ion detection function is accomplished by the low energy curved plate analyzer, the high energy curved plate analyzer, the crossed field velocity filter, the low energy channeltron, and the high energy channeltron. Ions detected at the various voltage steps are counted and the data is provided to the data handling function.

The data handling function accepts digital and analog data from the other functional elements of the experiment, converts as necessary, commutates, and gates out the scientific and engineering data to the central data subsystem. A parity check is also generated in the data handling function.

Five command lines are provided from the ALSEP data subsystem to the SIDE/CCIG (Figure 2-71). Four of these lines are used to encode up to 15 different command functions; the fifth line provides an execute command to carry out whatever command is coded into the other four lines.

Two one-time commands are incorporated to permit activation of the CCIG Seal Break and Dust Cover Blow circuits.

SIDE Ion Detection Function. The low and high energy ion detectors count the positive ions within certain velocity and/or electron volt energy bands that enter the detectors within a specific time interval. The CCIG counts neutral atoms entering the CCIG sensor within a specific time interval and also monitors the temperature of the sensor to provide the data required for calculation of the lunar atmospheric pressure. The ground plane voltage control circuits control the electrostatic potential between the lunar surface and the SIDE ion detectors.

The low energy ion detector measures the differential energy spectrum of positive ions having energies between 0.2 and 48.6 electron volts per unit charge and masses between one and 120 AMU.

The high energy ion detector measures the differential energy spectrum of positive ions having energies between 10 and 3500 electron volts per unit charge regardless of mass.

The CCIG detector measures neutron atom densities corresponding to atmospheric pressures of 10^{-6} torr to approximately 10^{-12} torr.

SIDE Data Handling Function. The major elements of the data handling function are the status sub-commutator, analog-to-digital converter commutator, and the high and low energy count accumulators; all applying data to the strobe gate for transfer to the central data subsystem and subsequent downlink transmission to the MSFN. In addition, a parity generator provides a parity bit for each SIDE frame.

2.10 SOLAR WIND EXPERIMENT (SWE) (GFE)

The Solar Wind Experiment (SWE) subsystem measures energies, densities, incidence angles, and temporal variations of the electron and proton components of the solar wind plasma that strikes the surface of the Moon.

The experiment yields data that is being utilized to expand knowledge in the following scientific areas:

- a. The general properties of the solar wind.
- b. The properties of the magnetospheric tail of the Earth.

Operating with high gain modulation, the SWE measures electrons having energies between 10 and 1400 electron volts and protons having energies between 75 and 9600 electron volts with a minimum flux density of approximately 10^6 particles per square centimeter per second. The SWE has a field of view of approximately 6.0 steradians and is capable of determining the direction of a collimated plasma flux to within 15 degrees. The accuracy of SWE electronic measurements averages about three percent over a four decade dynamic range.

2.10.1 SWE PHYSICAL DESCRIPTION

Seven Faraday cups, designed specifically for the ALSEP Program, collect and detect the solar wind electrons and protons. The cups open toward different but slightly overlapping portions of the lunar sky. Data from each cup individually and from all seven cups combined are processed and fed to the ALSEP data subsystem for Moon-to-Earth transmission. Therefore, with a knowledge of the positioning of the SWE on the lunar surface, the direction of the bulk of charged particle motion can be deduced. Voltages on modulation grids of the cups are changed in sign and varied so that the cup will differentiate between electrons and protons and between particles having different energies.

Accuracy of SWE measurement data is checked by the readout of internally generated calibration signals. The signals are processed through the measurement and data handling sections of the SWE to check their operation.

The SWE output signal is a serial, non-return-to-zero digital train that is accepted by the data subsystem at the rate of four words per ALSEP telemetry

frame. A complete SWE measurement cycle is organized into 16 sequences of 186 ten-bit words. Each word of each sequence contains a specific element of data. The words are identified within the sequence by the first two bits of the word and the sequence is identified by the least significant bits of the 185th word of the sequence. Of the 186 words in each sequence, 112 words contain positive particle measurement data, 56 words contain negative particle measurement data, 16 words contain SWE calibration and operation data, and two words contain sequence and cycle identification data.

Physical and electrical properties of the instrument are shown in Table 2.10-1.

SWE Sensor Assembly. The sensor assembly consists of seven Faraday cups arranged in a hexagonal cupola configuration. One cup is mounted on each of the six sides of the cupola and one cup is mounted on the top of the cupola so that it faces upward after deployment on the lunar surface.

Thin, spring-loaded covers protect the cups from contamination by dust during handling, lunar deployment, and LM takeoff. After LM takeoff in response to a command initiated on Earth, the covers are released and ejected.

A sun sensor device, consisting of a slit on the top of the sensor housing through which sunlight can enter and a photoelectric cell circuit, will indicate leveling of the SWE after lunar deployment.

SWE Electronic Assembly. The electronic assembly contains all the circuits required to modulate the plasma flux entering the Faraday cups and to convert cup output signals, calibration data, and operation data into appropriate digital format for the ALSEP data subsystem. The assembly consists of the following modules:

- a. Module 100 - Signal Chain
- b. Module 200 - Programmer
- c. Module 300 - Power Supply and HV Modulator

Heaters in the assembly keep the electronics warm enough for proper operation during lunar nights.

SWE Thermal Control Assembly. The thermal control assembly includes a set of three radiators on one vertical face and insulation covering the other five faces of the electronic assembly. A sunshield prevents direct sunlight

Table 2.10-1. SWE Leading Particulars

Characteristic	Value
Dimensions	
Stowed	9.0 x 11.1 x 10.6 inches
Deployed	12.0 x 11.1 x 13.6 inches
Weight on Earth	12.5 pounds
Input voltage	28.25 to 29.30 volts
Input power	3.2 watts average. No more than 6.5 watts except briefly for starting transients, dust cover removal, and high voltage gain change command.
Measurement ranges	
Electrons	
High gain modulation	10.5 to 1376 electron volts
Low gain modulation	6.2 to 817 electron volts
Protons	
High gain modulation	75 to 9600 electron volts
Low gain modulation	45 to 5700 electron volts
Field of view	6.0 steradians
Angular resolution	15 degrees (approximately)

from reaching the radiators. The thermal control assembly, together with the heaters, maintains the temperature of the electronics within the range for proper operation through all variations in lunar surface temperature.

SWE Leg Assembly. The leg assembly consists of two tubular A-frames containing telescoping legs. The legs were extended manually during SWE deployment on the Moon. A button on each A-frame locks the legs in position.

2.10.2 SWE FUNCTIONAL DESCRIPTION

The SWE is a highly sophisticated scientific instrument that detects the type, quantity, and directional characteristics of solar wind plasma and supplies this information, in the required digital format, to the data subsystem on demand.

The SWE uses a modified Faraday cup as the basic detector. The Faraday cup diagram is shown in Figure 2.10-1. The cup measures the current

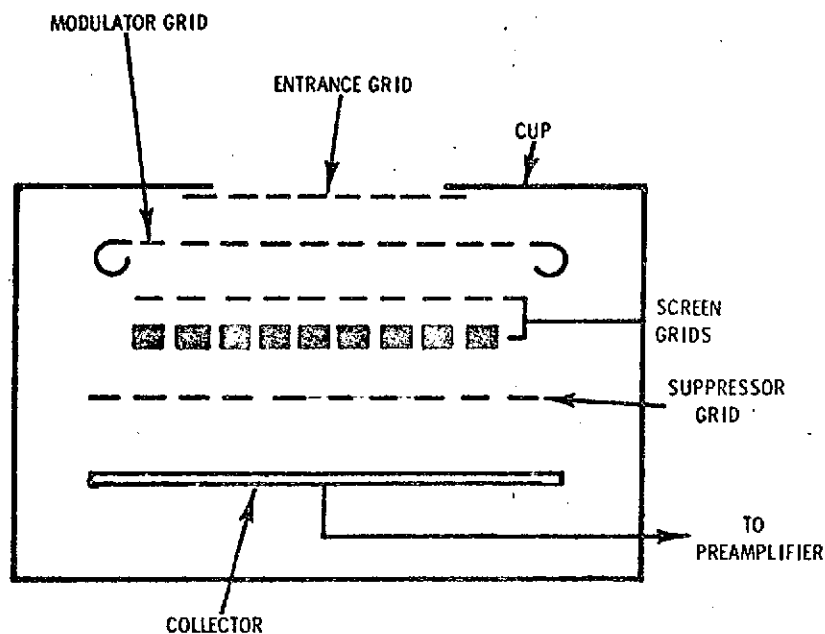

Figure 2.10-1 SWE Faraday Cup Diagram

produced by the charged particle flux entering it. The energy (more accurately, the energy per unit charge, E/Q , associated with the component of velocity normal to the grid plane) and polarity of the particle are determined by placing a retarding potential, V , upon a modulator grid near the cup entrance and measuring the change in current, Δi , with a known change in retarding potential, ΔV . The change in current, Δi , is then, a result of the flux of particles that possess the proper polarity and energy to be within the portion of the energy spectrum associated with voltages V and $V + \Delta V$. Using a series of ΔV 's, the entire range of voltage (both positive and negative) is swept out to give a complete energy spectrum of the charged particles.

The basic principle of plasma detection in the SWE is to apply to the modulator grid of a Faraday cup a square wave retarding potential, having both ac and dc components, which modulates the flow of charged particles within a particular energy range and then to synchronously demodulate the ac current resulting from the collection of these particles. This scheme makes it possible to discriminate against the constant flux of photoelectrons produced in the instrument by electromagnetic waves (primarily solar ultraviolet light).

To be sensitive to solar wind plasma from any direction above the horizon of the Moon and to ascertain angular distribution of plasma flux, the SWE has an array of seven cups. Since the cups are identical, an isotropic flux of particles produces equal currents in each cup. For an anisotropic flux, analysis of the relative amounts of current in the seven collectors determines the variation in plasma flow with direction.

The electronics of the SWE supplies the modulating voltage, identifies the currents caused by flux in each Faraday cup, and conditions this information so that it can be sent to the ALSEP data subsystem, telemetered to Earth, and analyzed. A sequence of measurements whose conditions are known by a prior knowledge of the sequence and by a calibration of voltage and current response is produced to provide the data necessary for interpretation.

Information is provided on the following:

- a. Flux intensity - Deduced from knowledge of the magnitude of the collected currents and the effective aperture size. The number of particles detected per second is equal to the current measured by a sensor, divided by 1.6×10^{-19} coulombs, the charge of an electron or proton.

- b. Direction of mean velocity - Deduced from knowledge of the sensor geometry, orientation of the SWE on the lunar surface, and relative current readings from the seven cups. The direction will be able to be deduced to within fifteen degrees or less, depending on plasma temperature.
- c. Energy of the particles - Deduced from the direction of mean velocity and the relative responses to the various modulating potentials applied to the repelling grid of the cup. (Assumptions are made regarding the mass and charge of the particles.) For paraxial particles, the particle energy in electron volts is between the upper and lower limits of the modulating grid potential.
- d. Type of particles - Deduced from the polarity of the voltage on the modulating grid and from the energy spectrum. A positive grid voltage corresponds to measurement of positive ions and a negative grid voltage corresponds to measurement of electrons. Protons, electrons, and particles are known to comprise the vast majority of solar wind particles.
- e. Density of particles - Deduced from the velocity and flux intensity of the solar wind.
- f. Particle temperature - Deduced from the energy spectrum of the particles and a detailed knowledge of the SWE response to particles. The higher the temperature, the broader the peak in the energy spectrum.

The SWE requires only power and synchronizing signals to provide a continuous train of digital data on the solar plasma impinging on it.

Operation of the SWE may be classified into the functional activities shown in Figure 2.10-2. These activities are measurement, modulation, sequencing, data handling, power supply, dust cover release, and heaters.

The measurement function detects the solar wind plasma entering seven Faraday cups and produces a dc voltage proportional to the plasma flux.

The modulation function generates modulation voltages that are applied to grids of the Faraday cups.

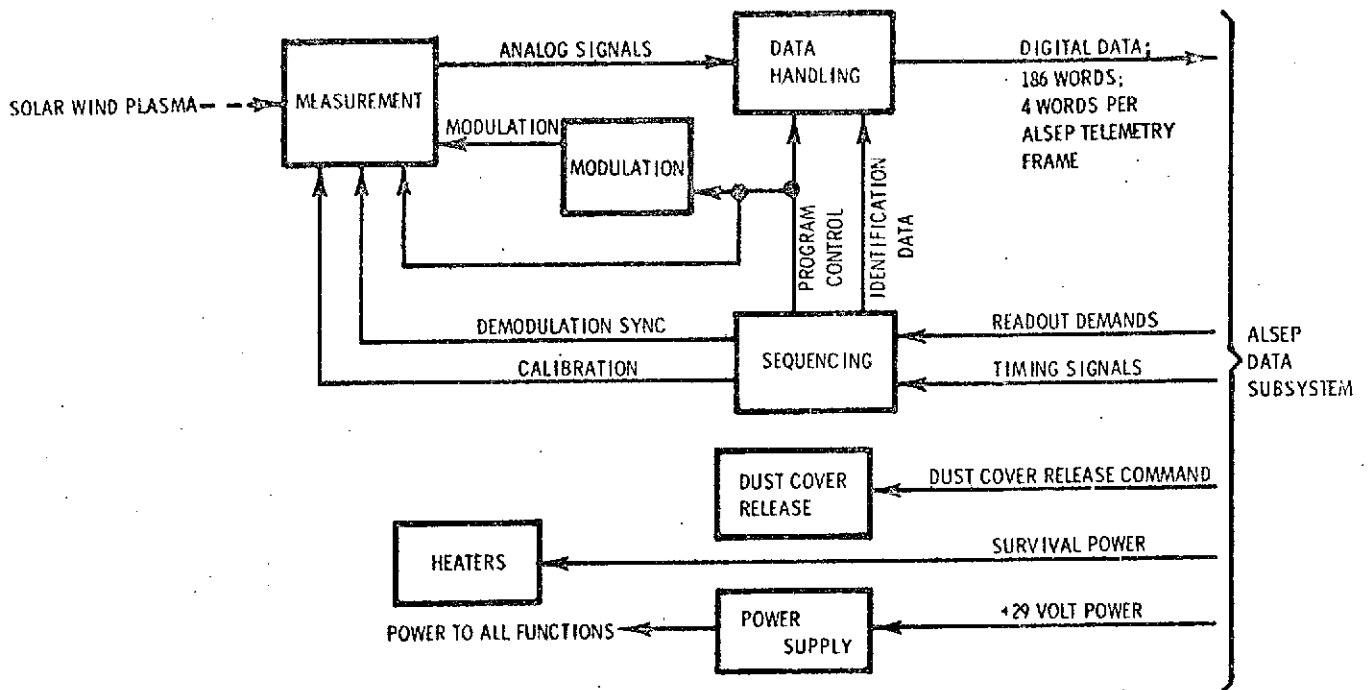

Figure 2.10-2 SWE, Functional Block Diagram

The sequencing function provides signals to control various operations of the SWE in conformance with the sequence of the ALSEP data subsystem telemetry format, provides phasing signals to a synchronous demodulator in the measurement function, and provides calibration voltages for the measurement function.

The data handling function converts the analog signals from the measurement function and from several operational sampling transducers to digital signals and combines the digital signals with identification data provided by the sequencing function so that the data are compatible with the requirements of the ALSEP data subsystem for the transmission to the Earth and for subsequent analysis.

The dust cover release function permits protective dust covers, held by springs over the seven Faraday cups, to eject from the SWE on receipt of a command signal.

The heater function maintains the temperature within the electronics assembly at proper operating temperatures.

2.11 COLD CATHODE GAUGE EXPERIMENT (CCGE) - GFE

The cold cathode gauge experiment (CCGE) comprises the cold cathode ion gauge (CCIG) and associated electronics. The purpose of the experiment is to measure the density of the lunar atmosphere. The CCGE will determine the density of any lunar ambient atmosphere, including any temporal variations either of a random character or associated with lunar local time or solar activity. In addition, the rate of loss of contaminants left in the landing area by the astronauts and lunar module (LM) will be measured.

The cold cathode ion gauge (CCIG) and the electronics make up the two basic subassemblies of the CCGE. The CCIG performs the required sensing while the electronics develops the scientific and engineering data measurements which are routed to the ALSEP central station data subsystem. The CCIG detects densities corresponding to pressures of 10^{-6} torr to approximately 10^{-12} torr. All numerical parameters are contingent upon known temperatures, anode voltages, and related magnetic/electrostatic field strengths. The normal gauge accuracy (including reproducibility) is 30% above 10^{-10} torr and $\pm 50\%$ below 10^{-10} torr. At 10^{-10} torr, the starting time for the gauge does not exceed 45 minutes at 23°C in total darkness and while operating at rated voltages and related magnetic/electrostatic field strengths. Above 5×10^{-9} torr, the starting time will be instantaneous.

The cold cathode gauge experiment (CCGE) is designed to sense the particle density of the lunar atmosphere immediately surrounding its deployed position. an electrical current is produced in the gauge, proportional to particle density. This current is amplified and converted into a 10 bit digital word and transmitted to ALSEP at a prescribed time in the ALSEP telemetry format.

2.11-1 CCGE PHYSICAL DESCRIPTION

The cold cathode gauge experiment consists of a cold cathode ion gauge assembly (CCIG), electronics package, and structural and thermal housings. Table 2.11-1 lists the leading particulars of the CCGE.

Cold Cathode Ion Gauge. The CCIG is made of type 304 stainless steel. The gauge is connected to the electronics package by a short cable. All feedthrough insulators are high alumina ceramic designed for ultra-high vacuum use. The CCIG aperture is sealed against ingress of dirt and moisture. The seal is removed, on ground command, by an explosive actuated piston releasing a spring.

Table 2.11-1 CCGE Leading Particulars

Characteristic	Value
Height	13.38 inches
Width	4.625 inches
Depth	12 inches
Weight	13.0 pounds
Instrument operational power	2.0 watts
Heater power	4.5 watts
Input voltage	+29 vdc

CCGE Electronics Package. The electronics package contains the power supplies, electrometer amplifier assembly, temperature, squib, and logic circuitry. The logic circuitry of the electronics package consists of nine modules using integrated circuits. The integrated circuits are supported by two strips of mylar with interconnect leads welded externally to the support mylar. The modular package is mounted to a 23-pin header coated with silicone and potted. The nine modules are soldered to the printed circuit motherboard of the electronics package assembly.

Structural Housing. The structural housing consists of a base and a fiber-glass housing for the electronic circuits and the gauge sensor. The top plate serves as a support for the electronic modules and as a heat sink. For deployment and leveling a tool socket and the bullseye bubble are mounted on top of the housing. Leveling is within five degrees.

Thermal Control. The structural housing is covered with a thermal coating to aid in maintaining the internal (electronics) temperature between -20 degrees C and +80 degrees C during normal operation when exposed to the lunar environment. A sunshield is used with a reflector to shade the thermal plate from direct sunlight and to allow it to view deep space. The reflector also reduces heat input from the lunar surface. An auxiliary electric heater is provided to maintain the internal temperature during non-operating periods and to assist in the thermal control during normal operation.

2.11.2 CCGE FUNCTIONAL DESCRIPTION

The CCGE is divided into four major functional elements; measurement function, timing and control function, command function, and data handling function (Figure 2.11-2). In addition, a power supply function provides system power to all operational circuits and a thermal control function maintains thermal equilibrium of the experiment on the lunar surface.

The measurement function is accomplished by the cold cathode ion gauge (CCIG), the electrometer amplifier, and the gauge temperature sensor. The lunar atmospheric particles are detected by the gauge and amplified by the electrometer. In the automatic mode, the sensitivity of the electrometer is automatically controlled by the timing and control function. Seven ranges of sensitivity are available.

The timing and control function provides range control signals to the measurement function and timing signals to the data handling function. The range sensitivity stepping of the electrometer amplifier is controlled by the timing and control function when the CCGE is in the automatic ranging mode of operation. The timing and control function also provides calibration timing to the measurement function. The function uses, shift, frame mark, and data demand pulses from the ALSEP central station to control its internal timing.

The command function accepts ground command pulses from the central station data subsystem, decodes the commands, and applies them to the timing and control function or the measurement function as appropriate.

The data handling function accepts digital and analog data from the other functional elements of the experiment, converts as necessary, commutates, and gates out the scientific and engineering data to the central station data subsystem at word times required by the telemetry format of ALSEP central station.

The major elements of the data handling function (Figure 2-104) are the analog multiplexer, analog-to-digital converter, and the data transfer register. All of the data handling functional elements operate to apply science and engineering digital data to the data transfer register for transmittal to the central station data subsystem and subsequent downlink transmission to the MSFN in a digital word format.

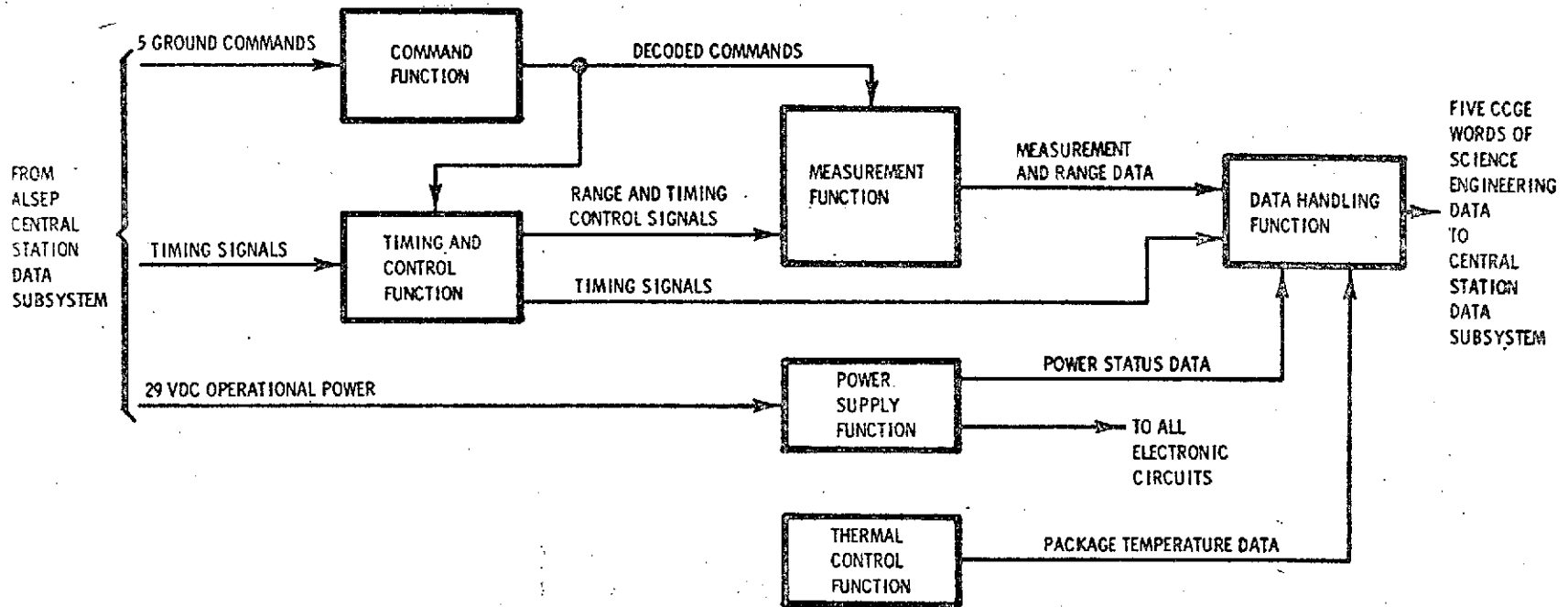

Figure 2.11-1 Cold Cathode Gauge Experiment, Functional Block Diagram

Science data, engineering data, mode data, range data, and control status data from all other CCGE functions are applied to the analog multiplexer for subsequent commutation. The sequence of commutation is determined by the multiplexer controller operating in the timing and control function.

Using the analog voltage from the analog reference source and the analog voltage from the analog multiplexer, the analog-to-digital converter performs a bit by bit successive approximation conversion of the analog data from the multiplexer and applies the resultant digital data to the data transfer register. The conversion time requires ten shift pulses or one data demand period prior to being shifted out to the central station. The eight bit data measurement is shifted out with the most significant bit first, followed by two bits of data identification and control data information from the multiplexer controller located in the timing and control function.

The data transfer register provides data storage during analog-to-digital conversion and data transfer during the ALSEP data demand period. The digital data output is composed of 10 bits that are serially transferred at the shift pulse bit rate during the appropriate ALSEP demand period. There are five CCGE words allotted for every ALSEP telemetry frame.

2.12 APOLLO LUNAR SURFACE DRILL (ALSD)

The Apollo lunar surface drill (ALSD) provided the means for an astronaut to implant heat flow temperature probes below the lunar surface and to collect subsurface core material.

The ALSD is designed as a totally integrated system which interfaces with the ALSEP pallet located in the LM during transit from earth to the moon's surface. The ALSD possesses the capability of drilling in lunar surface materials ranging from low density, fragmental material, to dense basalt. Implanting the temperature probes require drilling two holes to a maximum depth of three meters.

The ALSD is a hand-held battery-powered, rotary percussion drill consisting of four major elements; a battery pack, power head, drill string, and accessory group. Table 2-12-1 provides leading particulars of the Apollo lunar surface drill.

ALSD Battery Pack. The battery pack provides the power necessary for the lunar surface drilling mission. The battery pack comprises a battery case, battery cells, power switch, thermal shroud, and handle assembly.

Table 2-12-1. ALSD Leading Particulars

Characteristic	Value
Battery Assembly	
Silver-zinc cells	16
Open circuit voltage	29.6 ± 0.5 vdc
Operating voltage	23.0 ± 1 vdc
Nominal operating current	18.75 amperes
Nominal power capacity	300 watt-hours
Activated storage life	30 days
Recharge capability	3 cycles
Dry storage life	2 years
Electrolyte	40% potassium hydroxide
Cell pressure	8 ± 3 psig
ECS (case) pressure	5 ± 0.5 psig
Weight	7.24 pounds
Power Head	
Motor	
Operating voltage	23.0 ± 1 vdc
Load speed	9300 rpm
Load current	18.75 amperes
Efficiency	70%
Percussor	
Blow rate	2270 bpm
Energy per blow	39 inch-pounds
Spring energy	240 pounds/inch
Effective hammer weight	0.661 pounds
Hammer velocity	213 inches/second
Power Train	
Motor-to-cam ratio	4.1
Motor-to-drive shaft ratio	33.1
Drive shaft speed	280 rpm
Blows per bit revolution	8.1
Weight	8.37 pounds
Drill String Assembly	
Integrated length	126 inches
Extension tube length	16.75 inches
Drill bit	
Cutting diameter	1.032 inch
Body outside diameter	1.00 inch
Body inside diameter	0.802 inch
Length	2.5 inches
Number of carbide cutters	5
Inside cutting (core) diameter	0.752 inch
Weight	3.49 pounds
Hole Casing Sleeve (12)	
Wall Thickness	0.025 inch
Length	22 inches
Nominal diameter	1.0 inch

The battery case is a magnesium alloy enclosure with a pressure relief valve, electrical receptacle, and power switch. The battery has 16 individual cells and operates at a nominal output of 23 ± 1 volts dc at 18.75 amperes for 40 minutes. Each cell is constructed with a silver oxide primary, zinc secondary, and encased in a high temperature plastic. The battery cells are activated by filling each cell with an electrolyte during the pre-launch operations.

The power switch is a single-pole, single-throw, heavy-duty, microswitch with a push-to-activate mechanism. The switch portion of the assembly is contained by the battery case with the push-to-activate mechanism protruding through the case for external operation.

ALSD Power Head. The power head is self-contained within a housing which interfaces with the battery and drill string. The power head comprises a housing, motor armature, power train, clutch assembly, percussor, shock absorber, output spindle, pressurization system, and a thermal guard shield.

The motor armature is a nominal 0.4 horsepower, brush-commutated, direct-current, device employing as its field a permanent magnet. The armature is wound with copper wire protected by high temperature insulation. The motor possesses a peak efficiency of approximately 70 percent when operating at its nominal 9,300 rpm at an input voltage and current of 23 volts dc and 18.75 amperes, respectively. A reduction gear couples the output shaft of the motor armature to the power train.

The power train consists of reduction gears which provide the proper rotational speeds for the percussor cam gear and output drive spindle of 2270 blows per minute and 280 revolutions per minute, respectively.

ALSD Drill String. The drill string provides the cutting capability required for coring the hole in any lunar surface material which may be encountered ranging in hardness from dense basalt to unconsolidated conglomerate. The string is comprised of a core bit and eight extension tubes.

ALSD Accessory Group. The accessory group comprises extension tube caps, hole casings, hole casing adapter, rack assembly, treadle assembly, and a wrench.

2.13 APOLLO LUNAR HAND TOOLS (ALHT) SUBSYSTEM

The ALHT subsystem is a collection of equipments which were used by the astronaut to perform lunar surface observations and to collect lunar material samples.

The ALHT equipment can be classified into three categories according to function as follows:

- (a) Geologic sampling tools
- (b) Surveying and photographic instruments
- (c) Support and auxiliary equipment.

Geologic Sampling Tools

Aseptic collection device

This tool is designed to take a small sample of granular material or material of low structural strength from six inches below the lunar surface without exposing the sample to contamination.

Extension handle

This tool is of aluminum alloy tubing with a malleable, stainless steel cap designed to be used as an anvil surface. The handle is designed to be used as an extension for several other tools and to permit their use without requiring the astronaut to kneel or bend down. The handle is approximately 24 inches long and one inch in diameter. The handle contains the female half of a quick-disconnect fitting designed to resist compression, tension, torsion, or a combination of these loads. Also incorporated are a sliding T handle at the top and an internal mechanism operated by a rotating sleeve which is used with the aseptic collection device.

Core tubes

These tubes are designed to be driven or augured into loose gravel, sandy material, or into soft rock such as feather rock or pumice. They are about 15 inches in length

Core tubes (cont.)

and one inch in diameter and are made of aluminum. Each tube is supplied with a removable, non-serrated cutting edge. The upper end of each tube is sealed and designed to be used with the extension handle or as an anvil. Incorporated into each tube is a device to retain loose materials in the tube.

Scoop

The scoop is fabricated primarily of aluminum and has a riveted-on, hardened-steel cutting edge and a nine-inch handle. A malleable stainless steel anvil is on the end of the handle. The scoop is either by itself or with the extension handle.

Sampling hammer

This tool serves three functions; as a sampling hammer, as a pick or mattock, and as a hammer to drive the core tubes or scoop. The head has a small hammer face on one end, a broad horizontal blade on the other, and large hammering flats on the sides. The handle is fourteen inches long and is made of formed tubular aluminum. On its lower end, the hammer has a quick-disconnect to allow attachment to the extension handle for use as a hoe.

Tongs

The tongs are designed to allow the astronaut to retrieve small samples from the lunar surface while in a standing position. The tines are of such angles, length, and number to allow samples from 3/8-inch diameter to 2 1/2-inch diameter to be picked up. This tool is 26 1/2-inches in overall length.

Brush/Scriber/Hand Lens

A composite tool

- (1) Brush - To clean samples prior to selection
- (2) Scriber - To scratch samples for selection and to mark for identification
- (3) Hand lens - Magnifying glass to facilitate sample selection

Spring scale

To weigh lunar material samples to maintain weight budget for return to Earth.

Surveying and Photographic Instruments

Instrument staff

The staff provides steady support for photography. The staff breaks down into two sections. The upper section telescopes to allow generation of a vertical stereoscopic base of one foot for photography. Positive stops are provided at the extreme of travel. The bottom section is available in two lengths to suit the staff to astronauts of varying sizes. The device is fabricated from tubular aluminum.

Gnomon

This tool consists of a weighted staff suspended on a two-ring gimbal and supported by a tripod. The staff extends twelve inches above the gimbal and is painted with a gray scale. The gnomon is used as a photographic reference to indicate vertical sun angle and scale. The gnomon has a required accuracy of vertical indication of 20 minutes of arc. Damping is incorporated to reduce oscillations.

Color chart

The color chart is painted with three primary colors and a gray scale. It is used as a calibration for lunar photography. The scale is mounted on the tool carrier but may easily be removed and returned to Earth for reference. The color chart is six inches in size.

Support and Auxiliary

Tool carrier

The carrier is the stowage container for some tools during the lunar flight. After the landing, the carrier serves as support for the sample bags and samples and as a tripod base for the instrument staff. The carrier folds flat for

Tool carrier (cont.)

stowage. For field use, it opens into a triangular configuration. The carrier is constructed of formed sheet aluminum and approximates a truss structure. Six-inch legs extend from the carrier to elevate the carrying handle sufficiently to be easily grasped by the astronaut.

Field sample bags

Approximately 70 four inch by five inch bags are included in the ALHT for the packaging of samples. These bags are fabricated from Teflon.

Collection bag

This is a large bag attached to the astronaut's side of the tool carrier. Field sample bags are stowed in this bag after they have been filled. It can also be used for general storage or to hold items temporarily.

3. ALSEP DESIGN

3.1 SPECIAL DESIGN CONSIDERATIONS

Design of the Apollo Lunar Surface Experiments Package (ALSEP) presented a considerable challenge in that it had to accommodate the structural and thermal requirements of the experiments themselves; weight and volume limitations imposed by the nature of the mission; launch, flight, and landing environments; crew interface and deployment constraints on the lunar surface; and long-term operation in the lunar environment. Package hardware had to be capable of withstanding launch vibrations of up to 20 g's at science compartment temperatures ranging between 0°F and 160°F. Structural and thermal design had to afford post-deployment passive thermal protection to the ALSEP electronics and power system under exposure to the vacuum of space at an effective temperature of absolute zero (-460°F), as well as to direct solar radiation and lunar surface temperatures ranging from -300°F to +250°F. Also to be considered was the material degradation that would result from exposure to lunar dust, ultraviolet radiation, and charged particles.

3.1.1 THERMAL CONTROL CONSTRAINTS

The biggest technical problem that had to be solved was how to provide a reliable thermal control system for the ALSEP under the lunar surface temperature and dust conditions.

The requirement that all thermal control surfaces exposed to solar radiation in the ALSEP Central Station be capable of sustaining 100 percent dust coverage without degradation in system performance necessitated the development of a new structural/thermal design concept. This requirement could not be met by previously developed systems that use direct radiators in conjunction with low-solar-absorptance/high-emittance thermal control coating, because solar energy normal to any radiating surface on the moon produces peak temperatures of approximately 250°F if the surface is dust covered. In the case of a radiating surface such as the ALSEP data-subsystem thermal plate, the heat being dissipated from the internal electronics would increase this temperature by several hundred degrees if the dust layer were only 1/16 inch thick.

In developing the new thermal control concept, several other factors had to be considered. The thermal plate had to be kept in shadow for all solar angles between 0 and 180 degrees - that is, from sunrise to sunset. Solar heating angles and alignment requirements were complicated by the constraint that the ALSEP be deployable at any potential landing site within ± 45 degrees of the equator. Finally, although heat dissipations from the electronics of the various flight arrays would differ widely, the system had to maintain a fixed passive operating-temperature range for each array.

3.1.2 RELIABILITY CONSTRAINTS

The reliability required for continuous operation over periods of one and two years was obtained by:

1. keeping designs simple and eliminating unknowns. The ALSEP is necessarily a state-of-the-art system
2. designing electronics that utilize existing, proven-reliable piece parts (acceptable parts and materials lists)
3. performing extensive tests to verify the reliability of the piece parts used when proven parts were unavailable
4. derating all parts significantly with respect to applied thermal and electrical stresses to reduce the probability of stress failures
5. providing redundancy for critical functions and components
6. eliminating single-point failure modes in design
7. conducting an analysis of each failure noted in the test program to determine whether it was random in nature or indicative of a design deficiency requiring design improvement.

3.1.3 ASTRONAUT INTERFACE CONSTRAINTS

A number of severe human-factors constraints were imposed on ALSEP design, among them the spacesuit constraints, the 1/6-g environment, the extreme lunar lighting conditions, the weird lunar surface photometric function, and a variety of astronaut psychological factors. Like the reliability constraints, these constraints were met by keeping design mechanically simple and by making astronaut operations few and uncomplicated.

Extensive study and testing early in the program defined astronaut requirements with respect to reach heights, knob sizes, dial readability, force- and torque-applying limitations, and activity limitations imposed by astronaut fatigue factors. To validate astronaut capabilities, equipment functions, and task times, full-scale models were built and entire deployment sequences were enacted by spacesuited subjects.

3.1.4 SYSTEM OPERATION CONSTRAINTS

The communications facilities and operating procedures developed for the Apollo program influenced the development of the ALSEP data management system and imposed certain constraints on ALSEP design. Other constraints were imposed by the need for communicating with multiple ALSEP systems. Together, these design constraints led to the following ALSEP-downlink characteristics:

1. A unique transmitter frequency for each ALSEP, to avoid mutual interference between the ALSEP systems and with Apollo communications, in the S-band range of the MSFN receivers.
2. A unique identification code for each ALSEP, transmitted in the downlink data to facilitate proper data processing.

3. An ALSEP-downlink-carrier modulation compatible with MSFN receivers.

Two ALSEP-uplink characteristics also resulted from the MSFN constraints:

1. Uplink-command transmission to all ALSEP systems on a single S-band frequency, with an address code included to direct to the proper ALSEP.
2. An ALSEP-uplink-carrier modulation identical with the Apollo modulation except for the deletion of the 70-kilohertz intermediate frequency.

Design characteristics of the ALSEP antenna, through which both uplink and downlink signals pass, evolved from the MSFN constraints:

1. An antenna beamwidth wide enough to accommodate the effects of lunar librations. Because of these librations, the earth (as seen from the moon) appears to oscillate over a period of 28 days within a rectangle 14 degrees by 16 degrees, in a pattern that repeats only every 6 years. Allowing for misalignment tolerances, the antenna beamwidth was tailored to achieve, at 11 degrees off-axis, a gain only 2.2 decibels less than the boresight gain.
2. Antenna mounting on an aiming mechanism that provides for crew adjustment over the range of Apollo landing locations. The aiming mechanism permits alignment by the astronaut to the mean earth direction - i. e., to the effective center of the libration pattern. Dial settings for this alignment are computed in advance as a function of the expected lunar location and sun angle at the end of alignment.

With the gain of the ALSEP antenna fixed by beamwidth considerations, and with the performance parameters of the receiving stations established, the selection of ALSEP transmitter power and receiver sensitivity was dictated by signal-to-noise-margin, or bit-error-rate, requirements in the communications links.

3.2 KEY DESIGN FEATURES

Design of the ALSEP differed from that of previous space probes and scientific instruments in that a human interface was introduced, imposing mobility and dexterity limitations and visual and safety requirements. Several conflicting packaging configurations were suggested by area and volume constraints in the Lunar Module, in combination with requirements for survivability in the flight environment, operability in the lunar environment, and deployability with a minimum of crew participation. Moreover, redundancy had to be incorporated in all aspects of structural/thermal design to eliminate the possibility of single-point failures leading to partial or total system failure. Final design form and material selection was therefore based on trade-offs conducted with respect to weight, volume, form, strength, and functional and environmental considerations. The major mechanical features that resulted are detailed in Figure 14. Table 8 lists the most important system components and the materials chosen for their fabrication, along with the key characteristics or functions that governed the choice.

Two key concepts - those for fastener release and thermal control - were developed specifically to accommodate the configuration selected and the materials used in final ALSEP design.

The approach used for the Central Station and for several of the experiments incorporates a sunshield/specular-reflector/side-curtain arrangement that prevents solar radiation from falling directly on thermal radiating surfaces. Most of the thermal radiation from the lunar surface is reflected from the specular reflector so that it does not impinge on thermal radiation areas. The remainder of the experiment or Central Station is surrounded by a super-insulating thermal bag made up of multiple layers of aluminized Mylar, which thermally isolates the electronics from the external temperatures. Temperature gradients between equipment external surfaces and equipment electronics of up to 340 Fahrenheit degrees have been maintained over gaps of less than 0.25 inch.

In some experiments, dust covers close over instrument apertures and/or thermal radiating surfaces; these are removed by the astronaut following deployment or by remote command following Lunar Module ascent. The thermal radiating surfaces in such cases are assumed to be dust free. On Apollo 14 and subsequent flights, the Central Station and most of the experiments were protected by dust covers to reduce accumulation during astronaut deployment activities.

A thermal blanket approach was employed in the Passive Seismic Experiment, which had a thermal-control design goal of $125 \pm 2^\circ\text{F}$. A superinsulation shroud 5 feet in diameter covers the top of the experiment and is laid on the lunar surface surrounding the experiment. This blanket, in combination with the poor thermal conductivity of the lunar surface, tends to isolate the experiment from the large lunar surface temperature variations.

ALSEP packages were deployed at distances from the Lunar Module ranging from 300 to 1000 feet to ensure that the experiments would not be damaged by LM-ascent dust and debris or by plume heating effects.

3.3 MATERIAL SELECTION

Translation of ALSEP structural/thermal requirements into a final system configuration required the application of a number of new materials and processes, with emphasis on thermal control coatings and insulation films. The materials included solar reflectors, such as white paints, used to achieve low daytime surface temperatures; infrared reflectors, used to reflect infrared energy away from critical thermal surfaces; and high- and low-temperature films and multilayer blankets, used to insulate the electronics and other thermally critical equipment.

Some specific materials, their thermal properties, and their uses are listed in Table 9.

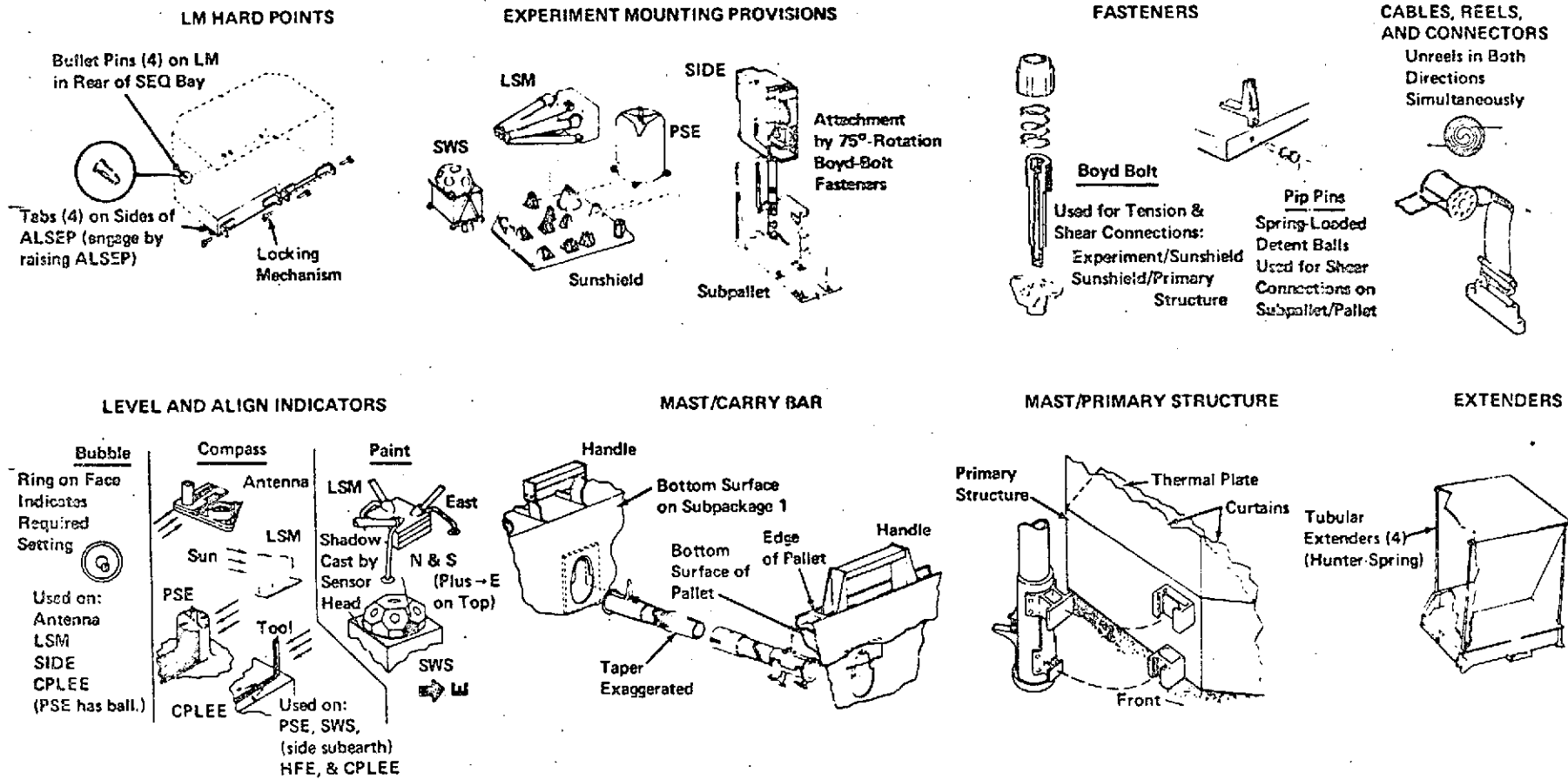

Figure 14 Major Mechanical Design Features

Table 8 Key Features of and Materials Selected for
Major Subpackage Components

Component	Material	Key Features and Characteristics
Primary Structure	aluminum (forged)	Has unique high-strength precision design. Houses electronics and is main support structure for equipment and experiments.
Thermal Plate	aluminum	Has high strength and flatness requirements. Supports electronics and provides flatness very critical to thermal-control heat transfer and electrical grounding.
Sunshield	aluminum (honey-comb)	Unique double-function structure that supports experiments in the stowed configuration and forms the top of the thermal enclosure in the deployed configuration.
Thermal Curtains and Masks	Mylar/fabric (alternating layers) Kapton (outer layer)	From three sides of five-sided thermal enclosure above thermal plate.
Cable Reels Flat Radio-Frequency	Teflon magnesium	Implement compact cable stowage and simple pull-out deployment. House permanent electrical connections.
Astromate	aluminum	Provides manual electrical-connection capability at deployment site.
Carry Bar	aluminum	Dual-function tool that forms dumb-bell-mode structural interconnections for carrying equipment, then serves as mast for the S-band antenna system.
Tools UHT DRT FTT	aluminum with CRES ^α interface fittings	Multipurpose handling tool used in ALSEP deployment. Tool for fuel-cask dome removal. Tool for transferring fuel from fuel cask to RTG.
Boyd-Bolt Fasteners	CRES ^α	Mechanical fasteners used on all ALSEP equipment.

Table 8 Key Features of and Materials Selected for Major Subpackage Components (Cont.)

Component	Material	Key Features and Characteristics
Sockets	aluminum/CR ES ^α	Implement UHT mating to all ALSEP components.
Release Systems		Devices keyed to require minimal astronaut exertion.
Velcro	nylon	Provides simple positive attachment.
Pull Rings	CR ES ^α	Simple-release handles.
Lanyards	Tufbraid	Provide access to remote release points.
Latching Mechanisms	aluminum/CR ES ^α	Have positive-locking features.
Clips	aluminum/CR ES ^α	Simple, quick-release locking devices.
Pins	CR ES ^α	Simple, quick-release locking devices.
Boom Assembly	titanium/aluminum	Implements remote release of the ALSEP from the LM.
Aiming Mechanism	magnesium/Vespel	Semiequatorial pointing device for aiming the S-band antenna toward a mean subearth point. Preset for prime landing site.
Leveling and Alignment Devices	aluminum/paints/films	Provided for all experiments, the antenna, and the Central Station.

^αCorrosion-resistant eutectic steel.

Table 9 Special ALSEP Surface Materials

Material/Finish.	Solar Absorptance α	Infrared Emittance ϵ	α/ϵ	Use	Temperature Limit, $^{\circ}\text{F}$
S-13G White Paint	0.20	0.9	0.22	solar reflector	350
Z-93 White Paint	0.18	0.95	0.19	solar reflector	500
Vacuum-Deposited Aluminum	0.10	0.02	5.0	infrared reflector	300
Gold Plating	0.25	0.04	6.2	infrared reflector	600
Aluminized Mylar	0.10	0.02	5.0	internal insulation layer and reflector	300
SiO ₂ Deposited on Aluminized Mylar	0.15	0.60	0.25	external insulation coating	300
Aluminized Kapton	0.47	0.80	0.59	external insulation layer	750
Aluminized Teflon (Type A)	0.17	0.70	0.24	external shroud material	400

3.4 DESIGN VERIFICATION

The ALSEP design was verified by completion of a detailed test program comprising three sequential steps:

1. Establishment of test requirements
2. Development of an integrated test program to satisfy these requirements
3. Conducting all tests with approved and verified test equipment using approved procedures for operating equipment and the collection and handling of data.

3.4.1 THE ALSEP TEST PROGRAM

To verify the ALSEP system design, detailed test requirements were established to demonstrate the operational modes, strength, endurance, and interface compliance of the hardware design. These basic requirements guided the generation of test plans and procedures. Thus, tests performed have demonstrated compliance, or, in the case of early hardware models, progress toward compliance with subsystem and system specifications.

In general, it was not feasible to test a complex system for all combinations of operational modes or stresses. Therefore, the selected tests were based on "worst case" stresses and operational models. Initially, engineering analysis and parametric studies identified worst case conditions; then, early development testing refined these concepts to define the qualification and acceptance test requirements. The achievable scope was limited by restraints on the feasibility of simulating operating conditions and interfaces for the ALSEP system.

Another factor that shaped the ALSEP test program was a set of ground rules which were based on Apollo Qualification Ground Rules. These rules and other appropriate comments follow:

1. Technical requirements were based on the need to demonstrate the operational performance and interface characteristics of the system. The test plan was designed to test all operational modes, demonstrate interface compatibility, and demonstrate the strength and endurance of the system. The technical requirements can be summarized by stating that the tests had to demonstrate the ability of the equipment to fulfill operational requirements and withstand environmental conditions to which it may be subjected.
2. The hardware level selected for qualification was the system level. This level allowed the most realistic test conditions and demonstrated system interactions with environments.
3. No formal life tests were planned. It was economically infeasible to conduct a single life test which was statistically meaningful. The mission simulation test total duration (for qual model hardware) was approximately equivalent to one month's lunar operation. This testing plus additional in-plant testing during qualification did yield qualitative data on failure trends.

4. Off-limit tests were not conducted on early flight qualification hardware. The use of the same (refurbished) hardware for qualification of other flight systems precluded destructive tests early in the program.
5. Qualification of ALSEP-GSE was not required since it was "mission support" not "mission essential".
6. The requirement of "reasonable assurance" that the equipment would complete qualification was satisfied by design verification tests conducted on prototype hardware. These tests included both functional tests and tests at design limit environmental conditions.

3.4.1.1 TEST SEQUENCE

The ALSEP test program had three major phases: development, qualification and acceptance.

Development testing started with breadboard and brassboard tests, and proceeded to engineering model tests and system tests of the prototype model. The objective of the development test program was to provide design information to Engineering concerning parts, components, subsystems, and systems for ALSEP.

The qualification test program objectives were to demonstrate integrated system performance, compatibility, and capability to withstand the effects of natural and induced environments. The qualification tests were planned to demonstrate normal operation and identify problem areas caused by inherent sensitivity to environment and potential failures not revealed or predicted in design reviews and reliability analyses.

The acceptance test program for flight hardware was designed to demonstrate that produced units were acceptable in that they did conform to a design previously proved in the qualification test series. The overall test program flow chart is shown in Figure 15.

Stress levels for environmental tests were based on specifications for ALSEP handling, flight, and lunar operations. These values were initially derived from:

1. Document LED 520-1F, "Design Criteria and Environments for LM," 15 May 1965
2. Document LIS 360-22302, "Environmental Conditions Induced by LM on Scientific Equipment, Descent Stage."

Although the levels listed in these documents were based on analysis alone, the documents represented the best source of environmental data during early phases of the ALSEP design. Further analysis, reported in ATR-16, and its Addendum 1, "ALSEP Dynamics Report," was performed by Bendix to refine the theoretical data and guide specification revisions.

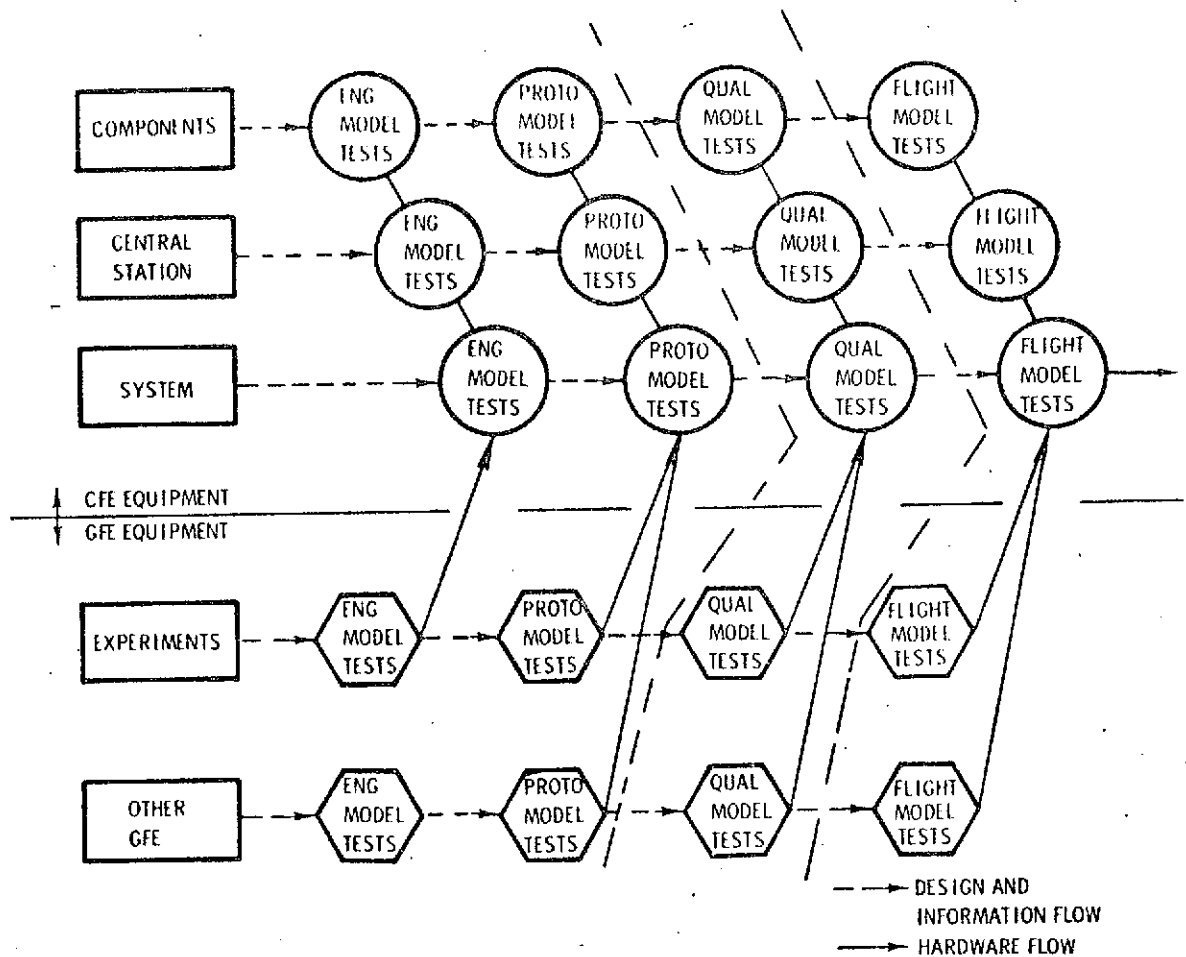

Figure 15 ALSEP Test Program, Flow Diagram

As the program progressed, ground test data became available from the LTA-3 and LTA-3 DR tests of the LM. The LTA-3 test provided lunar descent vibration data, while the LTA-3 DR test provided launch and boost vibration data. The acceptance test levels were based on these results, with the qualification levels set at 1.3 (sine) or 1.3^2 (random) times the acceptance levels.

Thermal test levels were based on estimates of the lunar surface temperatures and known values for the solar heat flux. The space chamber test conditions were adjusted to simulate these parameters.

3.4.1.1.1 DEVELOPMENT TESTS

The development test program was divided into two major elements. The first element consisted of parts and component tests, subsystem tests of the structural, thermal, and data subsystems, and system tests, using brassboard and engineering model hardware as listed in Table 10. These system tests, using early models of DSS components, also included the PCU and experiment subsystems.

Table 10 Development Test Program

Test Type	Parts and Components	Subsystem	System
Structural Tests	<ul style="list-style-type: none"> . Vibration Test Fasteners . Static Test Fasteners . Static Test Handles 	<ul style="list-style-type: none"> . Static Test Compartment No. 1 and 2 . Dynamic Test Comp 1 . Static Test Cask Mtg . Dynamic Test Cask Mtg . RTG Strain Test 	
Thermal Test	<ul style="list-style-type: none"> . Flat Conductor Heat Loss . Thermal Barrier Heat Loss . Contact Resistance Thermal Test . Reflector Test . T/V Calfax Fasteners . RTG Spacer Calibration . Cask Gearbox and Trunion T/V 	<ul style="list-style-type: none"> . T/V Test Comp 1 and 2 . Cask Cooling Test . Cask Thermal Vacuum . RTG Heat Leak Test 	
Electrical Tests	<ul style="list-style-type: none"> . Breadboard/Brassboard Tests <ul style="list-style-type: none"> . PCU . PDU . Command Decoder . Data Processor . Brassboard/Eng Model Tests <ul style="list-style-type: none"> . RF Components . A/D Conv/Multiplexer 	<ul style="list-style-type: none"> . Engineering Model Tests-DSS . Brassboard Tests-DSS 	<ul style="list-style-type: none"> . Tests of Engineering Models

The second element of the development test program was the testing of the prototype model as shown in Figure 16. Figure 17 is the test flow diagram for a typical "in-house" manufactured component. Figure 18 is the flow diagram illustrating the test performed in the integration of the Central Station. The test flow of an experiment, from receipt at Bendix Aerospace to integration, is shown in Figure 19. Figure 20 is the test sequence for experiment integration and system level test of the prototype.

3.4.1.1.2 QUALIFICATION TESTS

Mechanical environmental tests and functional tests were combined with simulated lunar environmental tests to qualify the total system. The environments to which ALSEP could be exposed were classified into various categories related to the system's operational phases such as assembly, transportation, launch, transit and lunar operations. The assumption was made that reasonable protection would be given to the system during all stages of handling, storage, and assembly, so that the system would not be unduly penalized in its design.

Operational performance tests were selected and designed to check all system functions and system compatibility. The basic performance test was an Integrated Systems Test. Certain other aspects of system performance such as EMI and magnetic properties were measured prior to the start of the formal qualification tests. This qualification test series was identical for both qualification and flight hardware. Intrasystem interfaces and performance were proved during the Central Station integration and acceptance test sequences.

In cases of environments having similar effects on the system, the most severe condition was chosen. The tests selected were: acceleration, shock, vibration, and thermal/vacuum/lunar simulation.

The shock and acceleration tests were both based on the lunar landing condition which gives rise to a long duration (260 msec) shock pulse. The use of two tests for this environment eliminated the need for nonstandard shock machines and was consistent with GAEC's subsystem test practice.

The vibration test was based on both launch boost environments and lunar descent and consisted of both random and sine vibration.

The thermal/vacuum test for design limit thermal conditions was conducted as a part of the mission simulation test. This test consisted of extended operation under nominal simulated lunar conditions. The test included a lunar morning system startup followed by operation at lunar noon, transition to lunar night, and operation at lunar night. This required approximately 25 days.

The necessity for an acoustics test was carefully reviewed in accordance with the "Criteria for Application of Acoustic Test," Method 515 MIL-STD-810A. The equipment design was considered to be insensitive to acoustic stimuli, since it

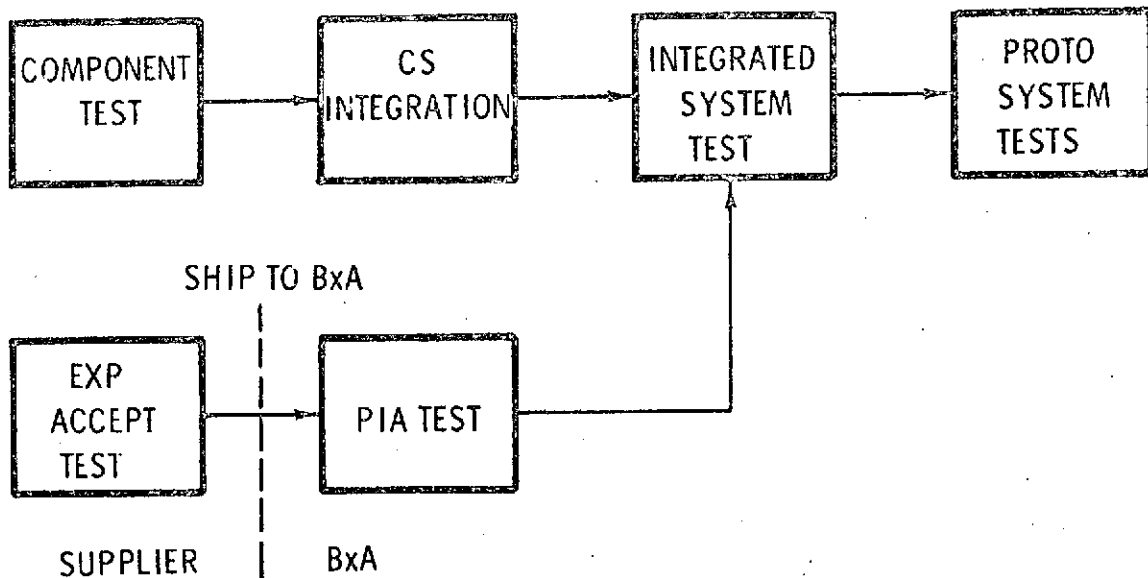

Figure 16 Prototype Test Program, Flow Diagram

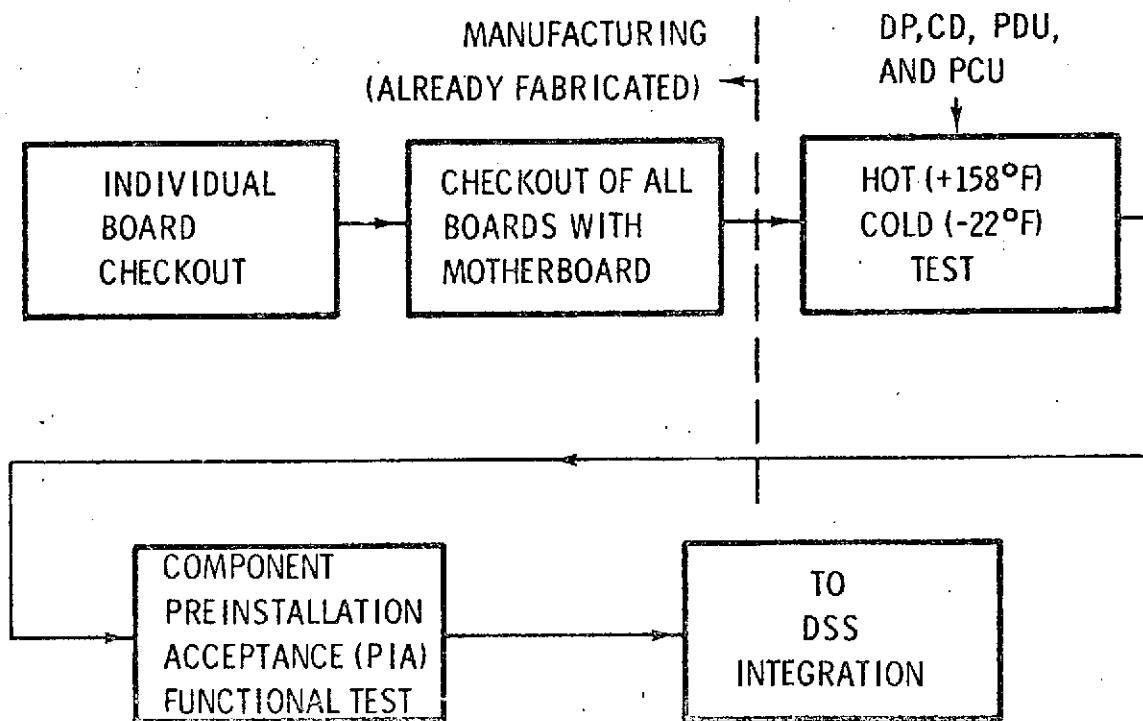

Figure 17 Prototype Component Tests, Flow Diagram

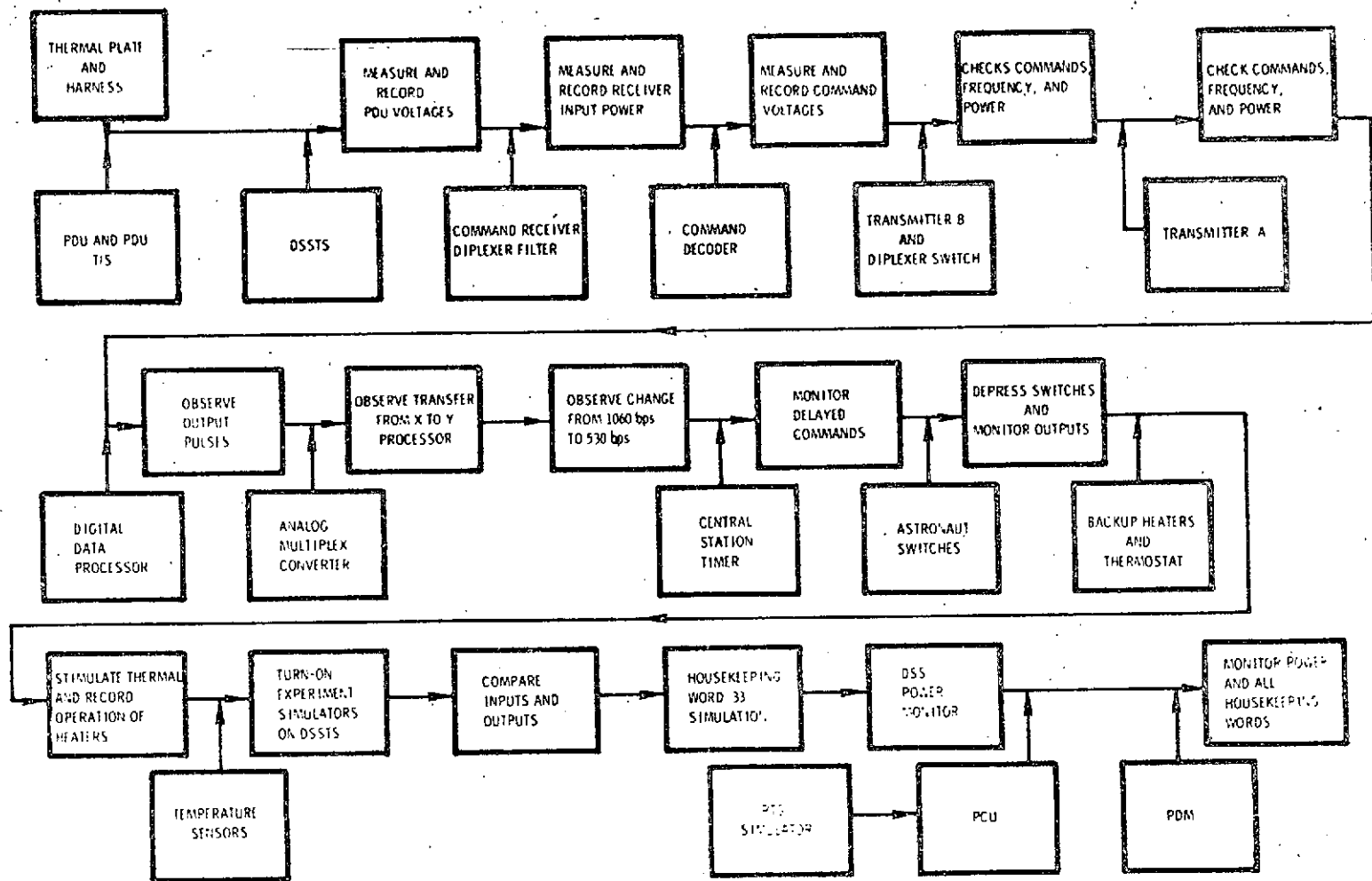

Figure 18 Prototype Central Station Integration Tests, Flow Diagram

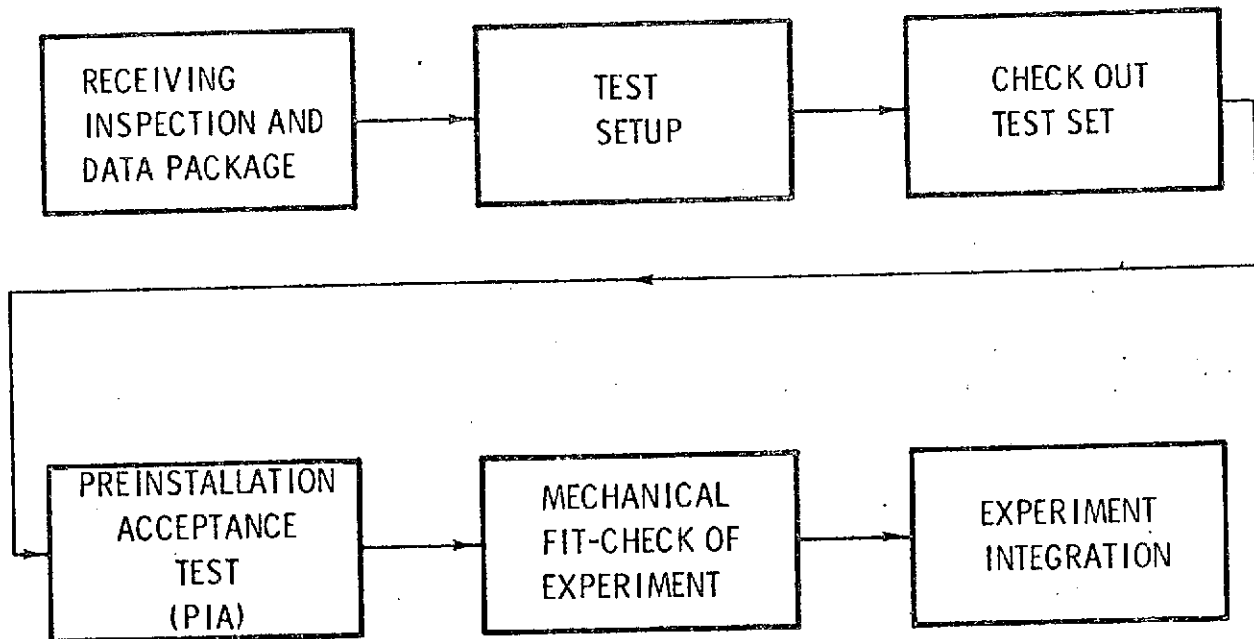

Figure 19 Prototype Experiment Tests, Flow Diagram

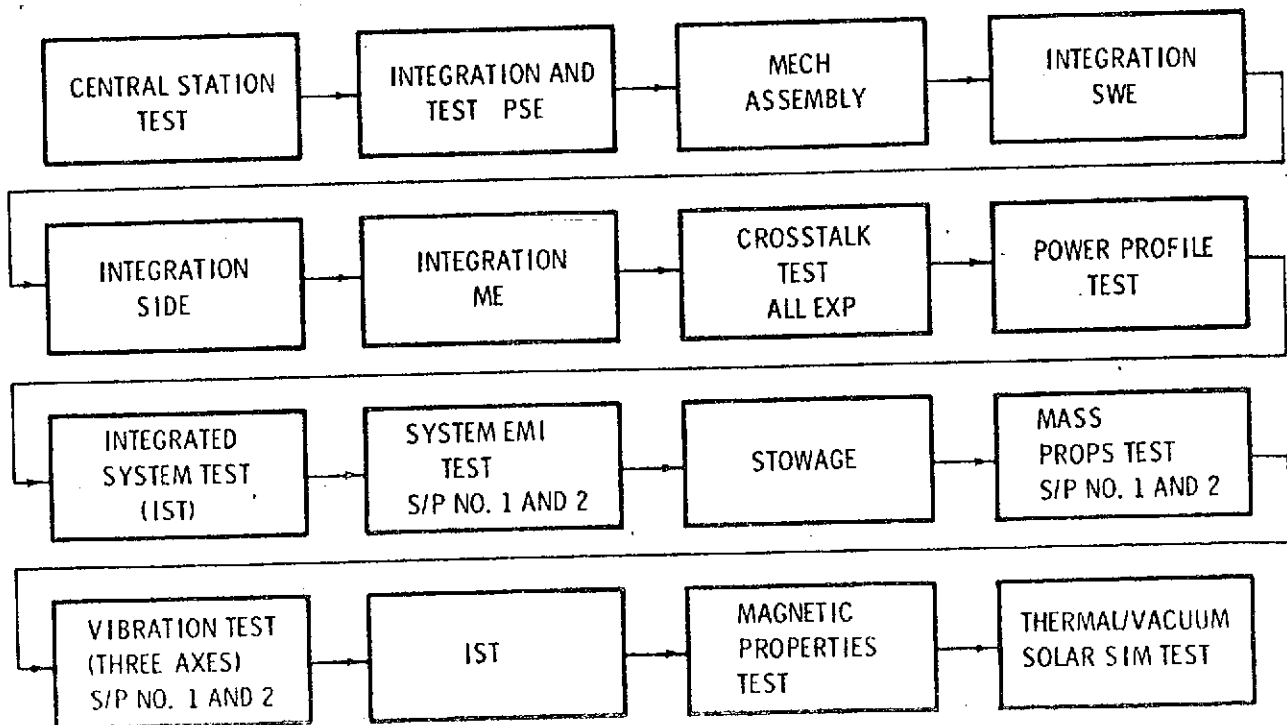

Figure 20 Prototype System Integration and Tests, Flow Diagram

had a high mass-to-volume ratio in all electrical components and had no micro-
phonic elements. In addition, the ALSEP system had no thin load-carrying panels
that were readily coupled to the acoustic source.

Humidity tests were excluded since it was more reasonable to place restrictions on
laboratory and checkout ambient environments and the protection offered by han-
dling and storage containers.

Human factors tests or tests of astronaut tasks were not a part of the qualification
program. While testing of this sort was originally contemplated, difficulties in
simulation, high costs, and the subjective nature of such tests led to their exclusion
from the qualification test program. Human factors considerations did, however,
play a major role in dictating system design. Additionally, astronaut tasks were
thoroughly evaluated.

Government-Furnished Equipment (GFE) was qualified by the furnishing agency
prior to ALSEP system level qualification. Bendix subcontracted equipment was
qualified by the vendor to ensure that the design met its specifications. These
tests were not a normal part of the qualification test program except in the areas
where the vendor's equipment did not see full system qualification levels.

A flow diagram of system level qualification tests is shown in Figure 21.

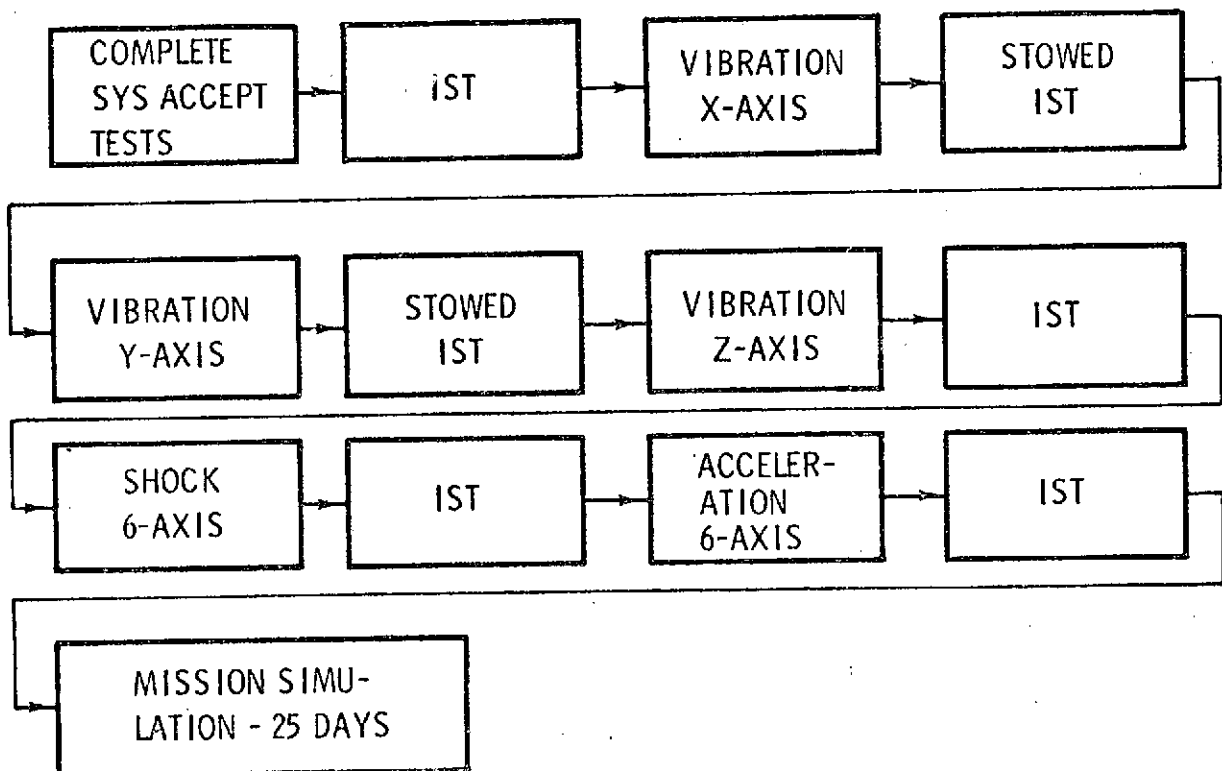

Figure 21 System Level Qualification Tests, Flow Diagram

3.4.1.1.3 ACCEPTANCE TESTS

Acceptance tests were selected to demonstrate that the system's performance was within specifications, and to demonstrate freedom from workmanship or material defects. Principal emphasis was placed on functional testing of the system, with environmental tests selected to expose any flaws in workmanship and materials. The two environmental tests most likely to reveal workmanship or material flaws were the vibration test and the thermal/vacuum test; therefore, both of these tests were conducted at predicted mission levels.

The acceptance test program utilized the "building block philosophy", with tests at every major level of assembly, and detailed integration tests during DSS and system buildup as shown in Figure 22. GFE and subcontractor equipment underwent acceptance tests prior to shipment to Bendix, and was again tested at Bendix prior to integration in the system.

The acceptance test program started with lower level assemblies, as shown in Figure 23. Vendor items (and experiments) follow the test sequence shown in Figure 24.

3.4.1.2 CONDUCT OF TESTS

All tests are formally documented as described in the following paragraphs.

3.4.1.2.1 DATA AND DATA CONTROL

Qualification and acceptance tests were conducted in accordance with approved test procedures. These procedures were released through the configuration management system in the same manner as engineering drawings and were controlled in the same manner. Changes required approved change request directives (CRD) and Engineering Change Notices (ECN). "Floor changes" were handled by variations to an individual procedure for a specific test or series of tests and required approval of the Test, Quality, and Engineering Departments. At the conclusion of the test, the test conductor reviewed all "as run" variations with the participants at a post-test meeting to establish what changes should be incorporated into future procedure revisions.

3.4.1.2.2 DATA VERIFICATION AND APPROVAL

During tests, all out-of-tolerance indications, failures, and malfunction conditions were cause for test stoppage and for the preparation of a Discrepancy Report (DR) by the Quality Department representative. The DR number was recorded on the procedure variation sheet, and a decision was made and recorded to continue the test, stop it, or "trouble shoot". If trouble shooting was elected, a plan was specified on the DR and approved by Test, Quality, and Engineering prior to proceeding. A reproducible copy was used as the master procedure and became the "as-run" record of the test. This as run procedure and the DRs were reviewed at post-test meetings with representatives of Test, Engineering, Quality,

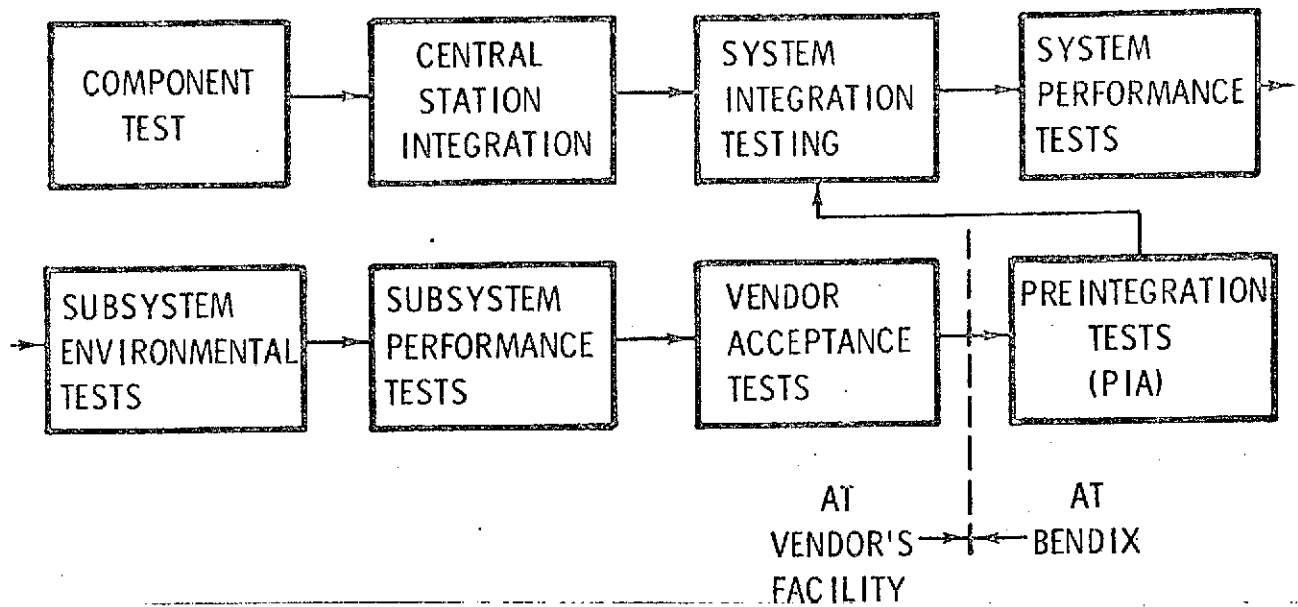

Figure 22 Flight System Acceptance Tests, Flow Diagram

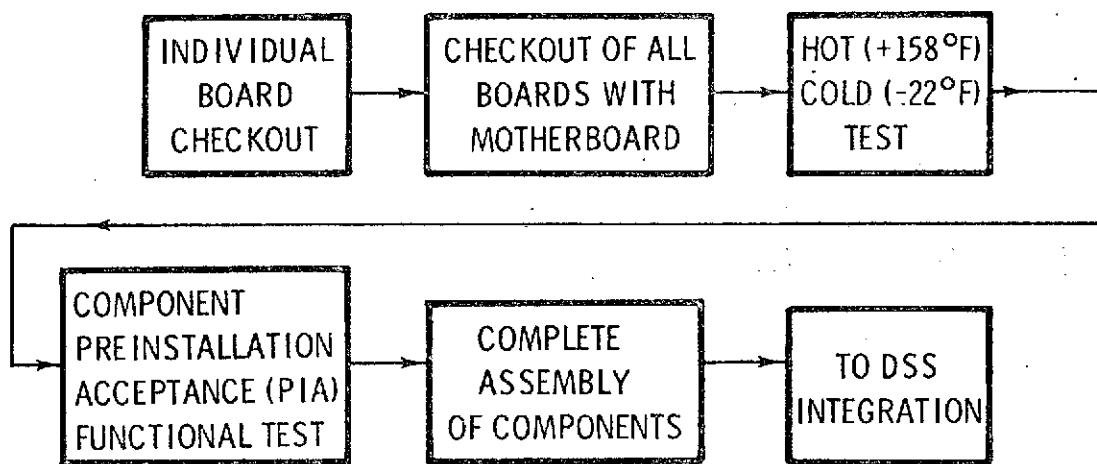

Figure 23 Component Acceptance Tests, Flow Diagram

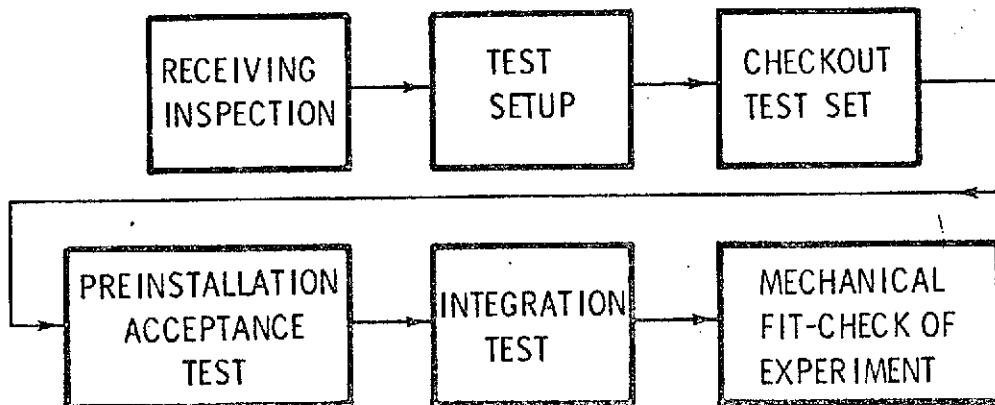

Figure 24 Experiment Acceptance Tests, Flow Diagram

and DCAS. These meetings provided tentative approval of test data; final approval was the prerogative of NASA, MSC.

3.4.2 TEST RESULTS

The ALSEP test program was applied during development, qualification, and verification of the ALSEP system design. An extensive amount of test data was compiled to fully characterize each component both as an individual item and as an integral part of the system and to verify system performance and design maturity.

System level tests were completed for four separate levels of hardware design.

1. Engineering Model System Tests - Following component development tests, engineering models of each component and subsystem were fabricated, tested for correct performance, and then assembled into a complete engineering model system. This system was thoroughly evaluated and provided a great store of data which were used in the development process to improve designs and correct design deficiencies.
2. Prototype Model System Tests - As designs were confirmed, Prototype Model components and subsystems were fabricated and integrated into a Prototype Model System. As a prelude to qualification, the system was fully tested and test data fed back to designers as necessary for further design refinement.
3. Qualification Model System Tests - Following closely behind the Prototype System, a qualification model system was fabricated and fully tested.
4. Acceptance Tests - The final test sequence was the formal acceptance tests for the flight equipment.

Both the Engineering and Prototype Model System Tests were successful in that they fully accomplished the intended end results. Additionally, the Qualification Model System Tests were successfully completed as evidenced by the Qualification Acceptance Reviews (QAR) documented by ALSEP Test Reports (ATR) as listed in Appendix B. The same is true for Acceptance Tests for the Flight Systems.

3.4.3 SYSTEM RELIABILITY

3.4.3.1 RELIABILITY GOALS

The ALSEP system specification established a design goal for an overall reliability of 0.90 for one year of lunar operation. It required that redundancy be utilized to achieve reliability and crew safety goals, and emphasized that the design must provide maximum resistance to single-point catastrophic failures. Subsystem reliability goals for a one-year period were also defined for the power, data, structure/thermal, and individual experiment subsystems.

A comparison of the specified reliability goals and predictions for ALSEP 1 equipment is shown in Table 11.

Table 11 ALSEP 1 Equipment Reliability Prediction

Equipment	Reliability Goal	Reliability Prediction
Power	0.9900	0.9819
Data	0.9642	0.8766
Structural/Thermal	0.9997	0.9926
Passive Seismic	0.9900	0.9051
Magnetometer	0.9900	0.7644
Solar Wind	0.9900	0.8543
SIDE/CCGE	0.9900	0.6803

The predictions represent the probability that the given subsystem equipment will successfully launch, survive transportation and landing on the lunar surface, deploy successfully, and perform all intended functions for a full year thereafter on the lunar surface.

Space and weight limitations for ALSEP presented the major barrier to meeting the numerical reliability goals defined for the experiments. The use of redundant data link, power, and command components was necessary to avoid high-risk, single-point failure modes in these support subsystems. Consequently, the ALSEP critical support systems reflect high reliability predictions consistent with their initial reliability goals. Experiments, on the other hand, did not represent system abort failure modes, and the lower reliability predictions reflected situations where redundancy was limited by system weight and space allowables. However, each experiment was at least 90% likely to transmit full scientific data for three months after deployment on the lunar surface.

3.4.3.2 RELIABILITY ENGINEERING

Quantitative reliability engineering considerations strongly influenced ALSEP design and development. Major factors were:

1. All single-point failure-mode risks greater than 0.005 for one year of operation were eliminated.
2. Passive thermal control system.
3. Maximum use of sealed parts and vacuum stable materials.
4. Critical component redundancy.
5. Standardization via BxA ATM-241 and ATM-242, Acceptable Parts and Materials Lists for ALSEP.

The foremost objective was the elimination of single-point failure mode risks in the design. Other primary objectives were: (1) to maximize the thermal control reliability by simplicity of design, (2) to eliminate space application failure modes by the maximum use of sealed parts and vacuum-stable materials, (3) to employ critical component redundancy as a backup for complex or high-risk equipment in the power and data handling support systems, and finally (4) to minimize the parts-and-materials failure risks by limiting design selection to the high reliability

standards set forth in Bendix ATM-241 and ATM-242, Acceptable Parts and Materials List for ALSEP.

3.4.3.2.1 SINGLE-POINT FAILURE MODES

All single-point failure modes which exist in ALSEP are passive, or very low risk of failure items. The results of ALSEP failure mode studies were documented during the program, and a final summary was published as ATM-501, ALSEP Reliability Failure Mode, Effects, and Criticality Analysis. The ALSEP single-point failure modes defined in the ATM-501 report, listed in the descending order of probabilities, are as follows:

1. Radiothermal Isotope Generator
2. Diplexer Filter
3. Fuel Cask Assembly
4. Antenna Assembly
5. Transmitter ON/OFF Control
6. Diplexer Circulators
7. PDU Cable Interconnect
8. Fuel Handling Tools
9. Boydbolts.

The RTG failure probability was predicted to have a value of 0.00525. The other failure modes listed represent less than one chance in 1000 for malfunction.

3.4.3.2.2 PASSIVE THERMAL CONTROL

The ALSEP structure and thermal control was of integrated design to provide a basically simple passive concept of thermal control. Structure, sunshields, thermal paints, reflectors, thermal bags (insulation), and heat sinks comprise the basic system.

3.4.3.2.3 SEALED PARTS AND VACUUM STABLE MATERIAL

Essentially, all electrical and electronic devices used on ALSEP have been selected from the ATM-241, Acceptable Parts List for ALSEP, which specifies hermetically sealed components. The few exceptions include the Central Station timer, an RTG shorting plug meter, and some semiconductors which were epoxy encapsulated. The timer and two types of epoxy sealed semiconductors used in multiplexers proved troublesome during ALSEP test programs. Vacuum stable lubricants were evaluated to resolve long-life timer performance in a vacuum. Changes in semiconductor packaging were investigated to eliminate the risk of multiplexer semiconductor malfunctions.

Metal items, such as tools, which must operate in the lunar vacuum were protected by microseal and other coatings to preclude the possibility of cold welding. All other materials selected for use on ALSEP, based on the ATM-242 BxA standards, proved to be fully qualified in tests.

3.4.3.2.4 STANDARDIZATION OF PARTS AND MATERIALS

Apart from design reliability improvement through redundancy, reliability in the ALSEP support systems and experiments was most effectively increased by the ALSEP Parts and Materials Reliability Program. The four primary results which established a high level of confidence in the reliability of ALSEP were:

1. Extensive usage of established high-reliability parts.
2. All parts power "burned in"
3. Functional/environmental stress analysis for each part in the circuit
4. Minimum of 50% part derating.

ATM-502, Electronic Composite Parts List for ALSEP, established that more than 85% of ALSEP electrical and electromechanical parts were high-reliability types, pedigreed by complete screening, burn-in, and life-test processing, which assured the highest level of reliability available from the part supply industry.

The balance (less than 15% of ALSEP electrical and electro-mechanical parts) was selected for applications not covered by existing "hi-rel" parts. In these cases, the best military or industrial standards were selected, and 100% screening and power burn-in of at least 168 hr were specified.

For all ALSEP flight hardware equipment, formal Parts Application Analyses (PAA) studies were performed to establish the functional and environment stress levels applied to each electrical part. Computerized circuit analysis programs were used to establish the maximum electrical load stress levels for each part at the maximum operating temperature conditions for ALSEP operation.

The PAA reliability studies documented the results via ATM reports, which establish that ALSEP electrical parts are subjected to 50% or less of their rated power dissipation.

3.4.3.3 RELIABILITY TEST MONITORING AND ASSESSMENT

Subcontractor reliability was monitored from test planning through the FACI stage to establish:

1. That all qual and flight model equipment was produced to approved designs
2. That all changes on qual and subsequent models were defined for the as-built hardware, and that such changes did not impact qualification status nor reduce the potential reliability
3. That all test procedures, procedure changes, and as-run test results were adequate to identify all significant malfunctions
4. That all end-item hardware malfunctions and failures were documented adequately to establish causes and corrective actions, with closeout based on Bendix approval.

System level reliability test monitoring and assessment at the Bendix system integration facilities included test planning, procedure configuration change control, and failure reporting system functions. In addition, the following test monitoring and assessment functions were performed:

1. All discrepancy reports (DRs) generated in all areas of manufacture, inspection, and test were reviewed and classified for cause analysis and trend data.
2. All DRs initiated by component Preintegration Assembly (PIA) and subsequent testing were marked for failure report (FR) or No-FR action and criticality classification code, to provide for investigation and documentation of every apparent failure of proto, qual, and flight hardware.
3. Failure Analysis Reports (FARs) were generated and their status was reported weekly.

3.5 DESIGN CERTIFICATION

Certification of ALSEP design maturity and the suitability of the scientific experiments package for use on a manned-flight mission was based on an evaluation of the following:

1. Design analyses
2. Intensive design reviews
3. Test readiness reviews
4. Results of extensive testing.

3.5.1 DESIGN ANALYSES

As an integral part of the ALSEP reliability program, a detailed design analysis was conducted on each major component and subsystem. The reports documenting these analyses provided confidence in the adequacy of the design, verifying appropriate applications and redundancy of parts of circuits. A listing of these reports is included in Appendix E.

3.5.2 DESIGN REVIEWS

The complete system design of ALSEP was formally reviewed by teams of specialists at appropriate points in the schedule. Preliminary Design Reviews (PDRs) of the prototype system culminated in the "Delta" PDR held during the week of 14-18 November 1966. Participants included representatives of NASA, Bendix, GAEC, GE, and the Principal Investigators for each experiment.

The Delta PDR resulted in a total of 17 Action Items, only three of which pertained directly to the design of ALSEP hardware. The balance dealt with documentation, GSE, handling and operational interface requirements.

The Critical Design Review (CDR) was held during 13-16 February 1967, to approve the design of all ALSEP hardware. The CDR resulted in only three action items, none of which pertained directly to ALSEP design.

3.5.3 TEST READINESS REVIEWS

To verify the suitability of ALSEP equipment, documentation, and facilities for intensive acceptance and design limit testing, detailed "readiness reviews" were convened immediately prior to the start of the test programs on the Qual and Flight Models.

3.5.4 TEST RESULTS

The extensive design limit and mission simulation tests performed on the Qual Model, and the acceptance tests performed on the Flight Model, considering the functional identity of the two models, resulted in a high level of confidence in the suitability of ALSEP for the lunar mission.

Results of the tests were documented in the series of test reports listed in Appendix B.

4. PROGRAM DESCRIPTION

4.1 SCHEDULES

The Aerospace Systems Division of The Bendix Corporation participated in the Preliminary Design Tasks (Phase I) of the ALSEP program, and submitted the Phase II proposal in February 1966. The NASA announcement of its intent to negotiate the ALSEP contract with Bendix occurred on 17 March 1966, and the contract was signed shortly thereafter. The ALSEP program, as it was defined for Phase II, is shown in Figure 25. (A condensation of the program schedule effective at that time.)

The ALSEP program schedule was paced by the Apollo program schedule with hardware design, fabrication, test and delivery phased to meet the planned Apollo launches. The ALSEP hardware design was required to meet the interfaces established by Apollo in terms of physical volume, weight, center of gravity and the human interface for crew handling during off-load and deployment on the lunar surface. Dynamic environments were provided as an output of the Apollo test program.

As with any large multi-faceted program, the ALSEP program experienced a number of changes required to keep pace with development of the overall Apollo program. Changes included such items as interface re-definition, schedule modifications, added equipment, change and refinement in test requirements, flight system re-assignment, addition of a new flight system (Array A-2) specification changes, etc. On 19 May 1962, incorporation of a number of such changes was directed by NASA. This resulted in a new (condensed) program schedule as shown in Figure 26.

The major elements of the revised program included the following:

1. The addition of a third flight configuration which was Flight System No. 4 comprised of the PSE, ASE, SIDE/CCGE, and CPLEE.
2. Subsystem level design verification tests on PSE, HFE, CPLEE, and ASE experiments.
3. Additional integrated system, EMI and MSFN tests on prototype models.
4. Additional subsystem and system EMI tests on qualification models.
5. Retrofit of the prototype model to use flight configuration of the data processor and power distribution unit.

The Schedule H (Figure 26) had the following key milestones:

Proto "A" DVT Complete	20 October 1967
Qual "A" Tests Complete	8 March 1968
S/T Subsystem Qual Complete	8 March 1968
Flight 1 Delivery	19 April 1968 (from 14 July 67)
Flight 2 Delivery	31 May 1968

Proto "B" DVT Complete	17 May 1968
Qual "B" Tests Complete	20 September 1968
Flight 3 Delivery	23 August 1968
Proto "C" Functional Tests Complete	12 Januray 1968
ASE Qual Tests Complete	20 September 1968
Flight 4 Delivery	4 October 1968
Program Completion	31 July 1969

Further revisions are shown in the condensed schedules of Figure 27 (29 Feb 1968) and Figure 28 (30 Sept 1968).

To keep pace with the Apollo program numerous other changes were necessary as the program progressed. Most significant however is the fact that in every case, ALSEP hardware deliveries met the Apollo program flight schedule requirements.

Figure 29 is a summary schedule showing the "as accomplished" program for Arrays A, B, C and A-2. Following sections contain descriptions of each of these program elements.



SCHEDULE

Title **FIGURE 25
ALSEP PROGRAM**

Issued On: 1-1-66
Updated On: 5-16-66 G

Line	Item	1966					1967					1968								
		M	A	M	J	J	A	S	O	N	D	J	F	M	A	M		J	J	A
1	Brassboard																			1
2	Data Subsystem																			2
3	Heat Flow																			3
4	ASE																			4
5	Block 1																			5
6	Model I-Structural/Functional																			6
7	Model E-1 Mech Sim for LTA-3																			7
8	Model D-1A Therm/Mech																			8
9	Block 2																			9
10	Model D-1 Therm/Mech Sim LTA-8																			10
11	Model H Eng Model Arrays A&R																			11
12	Block 3																			12
13	Model G Prototype A&R																			13
14	Model D-2 Therm/Mech Sim LM-3																			14
15	Model F Structure Sim (LM Fit Check)																			15
16	Block 4																			16
17	Model E-2 Training Sim																			17
18	Model B-1 Qual Array A																			18
19	Model A-1&C-1 Flight 1&Spares																			19
20	Model A-2&C-2 Flight 2&Spares																			20
21	Block 5																			21
22	Model B-2 Qual Array B																			22
23	Model A-3 Flight 3 & Spares																			23
24	Model A-4 Flight 4 & Spares																			24
25																				25
26	ALSEP Design Reviews																			26
27																				27
28																				28
29																				29
30																				30
31																				31
32																				32
33																				33
34																				34

Remarks

Figure 25

Prog Cont



SCHEDULE

Line	Item	1967				1968				1969									
		J	A	S	O	N	D	J	F	M	A	M	J		J	A	S	O	N
1	Wert Models																		1
2	(F) Structural Sim LM-3 1/F			▲															2
3	LM-4 1/F				▲														3
4	(D-1) Therm/Mech Sim LTA-8					▲													4
5	(D-2) Therm/Mech Sim LM3 1/F				▲														5
6	LM4 1/F								▲										6
7	(E-2) Training Sim		▲																7
8	A Configuration																		8
9	Prototype	■	■	■	■														9
10	Qual	■	■	■	■	■	■	■	■										10
11	Flight 1 Fab-Del					■	■	■	■	■									11
12	KSC Support									■	■	■	■	■					12
13	Flight 2 Fab-Del									■	■	■	■	■					13
14	KSC Support														■	■	■	■	14
15	B Configuration																		15
16	Prototype				■	■	■	■	■	■	■	■	■	■	■	■	■	■	16
17	Qualification									■	■	■	■	■	■	■	■	■	17
18	Flight 3 Fab-Del									■	■	■	■	■	■	■	■	■	18
19	KSC Support																■	■	19
20	C Configuration																		20
21	Prototype	■	■	■	■	■	■	■	■										21
22	Qualification									■	■	■	■	■	■	■	■	■	22
23	Flight 4 Fab-Del									■	■	■	■	■	■	■	■	■	23
24	KSC Support																■	■	24
25																			25
26																			26
27																			27
28																			28
29																			29
30																			30
31																			31
32																			32
33																			33
34																			34

70 52



SCHEDULE

Line	Item	1968												1969												1970												
		J	F	M	A	M	J	J	A	S	O	N	D	J	F	M	A	M	J	J	A	S	O	N	D	J	F	M	A	M	J	J						
1	Wert Models																														1							
2	(F) Fit Check Unit 1																														2							
3	Unit 2																														3							
4	Fuel Cask Mount																														4							
5	(D-1) Therm/Mech Sim																														5							
6	Fuel Cask Mount																														6							
7	(D-2) Mass Simulator																														7							
8	Fuel Cask Mount																														8							
9	(E-2A) Trainer																														9							
10	(E-2R) Trainer Mod																														10							
11	(E-2C) Trainer Mod																														11							
12	Fuel Cask Mount																														12							
13	B Interim Trainer																														13							
14	C Interim Trainer																														14							
15	Array A																														15							
16	Qual SA																														16							
17	Fuel Cask Mount																														17							
18	Flight 1																														18							
19	Fuel Cask Mount																														19							
20	Flight 2																														20							
21	Fuel Cask Mount																														21							
22	Array B																														22							
23	Prototype B																														23							
24	Qual SB																														24							
25	Flight 3																														25							
26	Fuel Cask Mount																														26							
27	Array C																														27							
28	Proto C																														28							
29	Qual C																														29							
30	Flight 4																														30							
31	Fuel Cask Mount																														31							
32																															32							
33																															33							
34																															34							

MASTER SCHEDULE

Title

ALSEP PROGRAM SUMMARY
ARRAY A, ARRAY B, ARRAY C, ARRAY A-2

FIGURE 29

No: _____
Revision No: _____
Issued On: _____
Updated On: _____

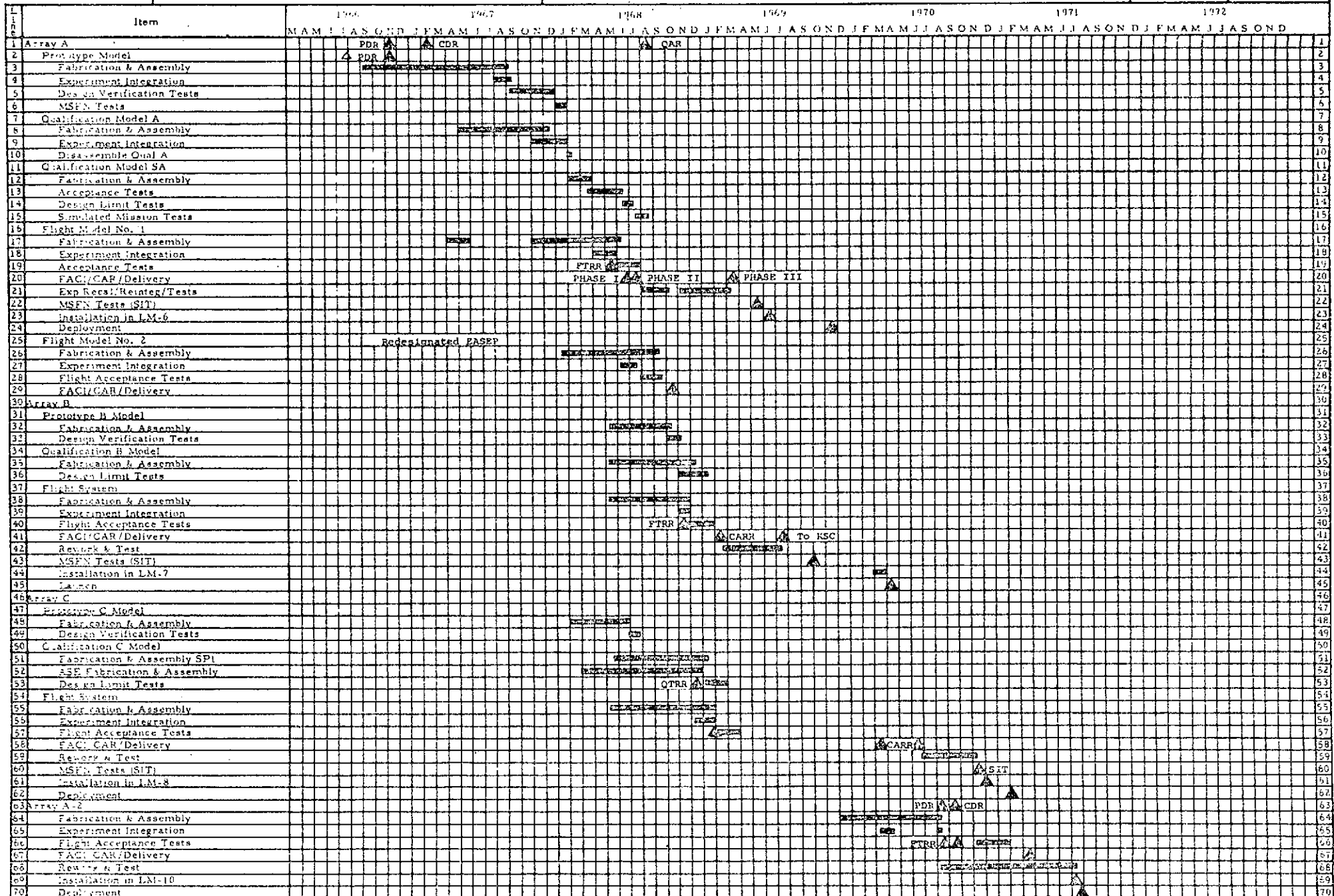

4.2 FLIGHT SYSTEMS

4.2.1 DESIGN DEVELOPMENT

During the first month, in accordance with the approved plan, the configuration decisions made in Phase I were reviewed. Principal parameters looked at were the utilization of weight, simplicity of astronaut tasks (not primarily to save him work but to assure system reliability) and power consumption (to give relief to experiments). The results of these studies were applied to the development of Phase II hardware.

Interface Control Specification agreement with the PI's was accomplished by the Interface Conference on 2 June, 1966. This provided a firm base line for equipment design early in the program.

Formal Preliminary Design Reviews (PDR) for 7 of the 10 ALSEP subsystems and of the entire system were held in July of 1966. There were no major changes imposed on the design. Basically, the Phase I design as further analyzed and improved during the first 3 months of the Phase II program was adopted for the flight units. It was the Bendix position that the hardware described was the flight model, and there would be no further changes to this design unless Bendix, MSC, or Principal Investigator definitively established that the defined design would not work.

The first program delivery, the Model E-1 Mechanical Simulator for LTA-3, was made on 20 July 1966. More engineering and equipment than was literally required by the contract was put into this model. Specifically, it included hard mockups of the Array A experiments properly ballasted to correct weight and cg with the intent of getting meaningful environmental data from the test of this model in the Grumman vehicle. These tests were postponed, so Bendix continued to base design on the Grumman ICD plus data derived from tests of the structural model. The original structure design was incorporated in the Block 1 models. To accomplish weight reductions, a new aluminum forging structure design was developed. It also had the advantages of improved structural integrity and the ability to hold tolerances more closely. Structural test results were obtained during acceptance testing of the Model E-1 mechanical simulator. The test data satisfactorily confirmed an extensive dynamic analysis which was completed in August 1966. Because of the new structure, nothing further could be learned, useful to flight design, with structural testing of the Model I. Therefore, Bendix proposed that necessary thermal modification be made to deliver the Model I as the Model D-1 Thermal/Mechanical simulator for LTA-8.

Bendix developed a new preprototype structural model (Proto 1) for structural tests of the flight configuration. The preprototype configuration was based on the prototype/flight unit layout, and provided for experiment mechanical fit check for both Array A and Array B.

The original plan was to refurbish the Model I for crew engineering tests after completion of structural testing. Bendix decided to build an entirely new interim trainer model for this purpose. It was a hard mockup model that reflected flight configuration as nearly as possible at the time, was suitable for crew engineering tests and simulations, and was a good forerunner for the Model E-2 Training Simulator.

The first significant test data from early models of equipments in all subsystems, both experiments and central station, were obtained in September of 1966. Data subsystem performance was satisfactory: tests with an LSM interface simulator were also performed.

In October 1966, MSC, the ALSEP Principal Investigators, Bendix, and its subcontractors conducted a 3-day symposium attended by NASA Headquarters, all other NASA Centers, and members of the scientific community. The background, objectives, design details, and current status of the ALSEP program were presented at that meeting.

In November 1966 a comprehensive design review (Delta PDR) was conducted by the Lunar Surface Program Office at BxA of the prototype design of the ALSEP system. During this 5 day meeting about 750 of the 900 drawings were reviewed in detail by over 100 NASA engineers, scientists, and astronauts. In December 1966, many individual subsystem, experiment and management meetings were held by mutual agreement.

Function of the engineering model (Model H) was to verify the Interface Control Specifications and functional performance of the central station working with all experiments. The Bendix central station and one experiment, the JPL Solar Wind, was ready on schedule on 1 November 1966. The engineering model tests were divided into four categories. Category 1 was the integration of the Bendix central station components. This was completed before 1 November. Category 2 was verification that experiments were functionally suitable and could be operated through their own experiment test sets. Category 3 was the demonstration that the experiments individually would perform with the central station in accordance with the ICSs. Category 4 was a demonstration that the complete ALSEP system including multiple experiments, final central station configuration and system test set were functionally suitable for the lunar mission.

The prototype model was used to verify the design, manufacturing processes, test procedures and especially the suitability of the flight design in the mechanical and thermal environment expected. The Lunar Surface Program Office established a design freeze on this prototype model as a result of the Delta PDR in November 1966. The Bendix policy on the prototype agreed to by Lunar Surface Program Office was that this model was flight configuration unless there were mandatory changes to make the system work.

The most significant problem areas in ALSEP design during 1966 were in the structure/thermal subsystem. Interface specifications were not firm with either the GAEC LM or the GE SNAP-27. The problem with LM was from continuing changes of the descent stage configuration in the vicinity of the scientific equipment bay. The fuel cask was at the heart of the problem in SNAP-27. The combined efforts of NASA, AEC, GE and Bendix resolved this problem during January, 1967. The delicate and sensitive re-entry-body cask, which required an expensive and delicate releast system for abort, was replaced by a structural graphite design which did not require release. The perturbations on the fuel cask impacted the cask mount schedules especially for simulator Models D1, D2, and F.

The Model F Structure Simulator for LM fit checks, built to the ICD with GAEC, was delivered to GAEC on 30 January 1967.

The Critical Design Review (CDR) of the ALSEP System was held in February, 1967. It was thorough and complete, and resulted in relatively few design changes.

The layout of the electronics package for the engineering model was made consistent with the new prototype structure and consistent with the thermal control requirements included in thermal mechanical model D-1A. The electronics subsystems in the engineering model were located as in the flight configuration, and the electronic components of each subsystem were packaged as in the flight configuration.

Thermal model D-1A was not a single piece of hardware but rather a program to verify the thermal control design of the central station, all experiments, and the fuel cask mount. The Bendix thermal control program was based on a feasibility of passive thermal control techniques demonstrated in Phase I, extensive analysis of realistic thermal models and verification of final design via full scale thermal vacuum testing. This thermal verification, or D-1 a program, was completed with excellent results. Feasibility was demonstrated in Phase I, the analysis was correct, and flight configuration was verified through full scale tests.

As of March 1967, the engineering model of the central station had been operating for five months without a major failure. All of the important interfaces, i. e., between the PCU and the data subsystem, between the experiments and the central station and between the central station and the system test set were completely compatible or were easily modified to obtain compatibility. Attention to detailed interface design in the early months of the program contributed to this success.

During March and April of 1967 final decisions were made by NASA on the experiment complement for all four ALSEP flight units. The nomenclature "Array A" and "Array B" was dropped in favor of Flight 1, 2, 3, and 4. On 17 March, the direction was given that Flights 1 and 2 would be identical and would consist of Passive Seismic Experiment, Lunar Surface Magnetometer, Suprathermal Ion Detector Experiment/Cold Cathode Gauge Experiment and Solar Wind Spectrometer. This complement is identical to the original Array A. On 13 April, Flight 3 was defined as Passive Seismic Experiment, Heat Flow/Apollo Lunar Surface Drill, Cold Cathode Gauge and Charged Particle Lunar Environment Experiment. Flight Unit 4 was defined as Passive Seismic Experiment, Active Seismic Experiment, Suprathermal Ion Detector Experiment/Cold Cathode Gauge Experiment and Charged Particle Lunar Environment Experiment.

The schedule for the simulator models D-1, D-2, and E-2 was paced by a completed detailed ICD on the cask and subsequent design and fabrication of the cask mount. Meanwhile, effort on these models proceeded on the basis that the cask mount hardware was the same as the prototype.

The Model D-1 thermal/mechanical simulator for LTA-8 (except for cask hardware) was completed in March 1967. The specification was approved, the advanced ADP was submitted, and the acceptance test procedure was completed except for the cask mount hardware tests which had not been defined.

The model specification for the D-2 thermal/mechanical simulator for the LM-3, was submitted for approval early in April. The design of Subpackage No. 1 was released in March and the final drawing on Subpackage No. 2 was released in late April. Proto 1 tests showed that application of the specified qual level vibration inputs to ALSEP on the Proto 1 Subpackage 1 resulted in input levels to the experiment models in excess of the levels specified in the ICS and derived from ATR-16, Addendum 1. Analysis indicated that this situation was likely to occur also in the Prototype A tests on Subpackage 1, and that higher than anticipated levels would also occur on Subpackage 2.

It had been expected that results of tests on the LM-6 at MSC would have been completed in time to verify the input levels to ALSEP in our specification. However, these tests were delayed and the data was not available in time to provide any new input levels for use in Proto A tests.

In April the separate CCGE was received from MSC for engineering model tests which it passed without significant problems. The experiment was very close to a true prototype configuration.

During October 1967, a second dynamic test was conducted on the "Proto 1" dynamic model of Subpackage #1 to obtain data on modifications to the LSM and SWS. The model used the original Proto 1 structure with a modified sunshield assembly, a dummy model of the PSE and GFE dynamic models of the LSM and SWS.

4.2.2 ARRAY A

4.2.2.1 PROTOTYPE A

The Prototype Model was used to verify the design, manufacturing processes, test procedures, and the suitability of the flight design in the mechanical and thermal environment expected.

Design freeze of the prototype model was established with LSPO during the Delta PDR in November 1966, LSPO concurred with the Bendix policy that the prototype model was flight configuration except for changes required to meet the system specifications.

All data subsystem components of the prototype model were completed on schedule on 17 February 1967. Central station component environmental tests were completed on 5 March. Vibration tests included sine and random vibration on all three axes to qual levels. The thermal vacuum tests were conducted from -27°F to $+163^{\circ}\text{F}$. Several discrepancies were discovered especially at the low temperatures. These were documented in standard Failure Reports. A few minor design discrepancies in printed circuit boards were corrected for qual models. A most interesting result was the failure of two non high-rel parts at the low temperatures. Even though the low temperature was substantially below the specified thermal controlled environment, this was an early and dramatic confirmation of the value of a high-rel parts program. Subsequent testing of these components with high-rel parts resulted in no failures.

A tentative conclusion was that integrated circuitry is most susceptible to the low temperature environment, and that each component should be given an ambient pressure - low temperature test as part of normal acceptance.

Integration of central station electronics on the thermal plate and checkout with the system test set was completed on schedule, 10 March.

The central station electronics, completed EMI tests in April. The difficulties encountered in the PCU at low temperature were corrected and the unit was successfully tested at full power with proper operation of both regulators. Pre-installation acceptance tests of the Passive Seismic and Solar Wind experiments and experiment integration of the SWS were completed in April.

On 19 May, when the initial re-direction of the program was received, the Prototype model was completing functional tests and experiment integration immediately prior to final mechanical assembly and initiation of design verification tests. The model was then disassembled and refurbished to some extent with items of flight design which could not be incorporated on the original schedule. In addition, the PSE, SWS, and SIDE/CCGE prototype models, previously integrated, were returned to their manufacturers for various additional tests and re-work.

The prototype system tests performed through 10 October include:

1. LSM integration.
2. Completion of PSE and SWS integration.
3. System cross-talk.
4. Integrated system test.
5. Central Station EMI test
6. Conducted and radiated interference portions of system EMI test.
7. ALSEP/EVA communications interference test.
8. Experiment mass-properties test (except LSM).

Generally, these prototype system tests successful, although specific discrepancies were encountered.

The Data Processor was found to have a malfunction in one of its redundant digital sections. The malfunction was isolated to the multiformat commutator board in the X section and tests continued with the redundant Y section. A repair of this malfunction was planned between the Proto A and Proto C tests.

In the area of prototype mechanical integration, the Subpackage #1 was stowed, deployed, and stowed again in preparation for mass properties, vibration, and magnetic properties tests. It was deployed again to complete EMI susceptibility tests, magnetic properties tests and thermal vacuum tests.

The prototype system tests performed through November 1967 included:

1. System EMI tests.
2. System vibration tests.
3. Post-vibration integrated system test.
4. Magnetic properties test-stowed and deployed.

In general, the results of these tests were encouraging. In particular, the post-vibration IST showed all elements of the system functioned as before the vibration. This gave reason for additional confidence in the basic designs.

A SIDE leg was broken as well as the SIDE mounting bracket; however, these were repaired and additional tests run successfully. An unacceptable dynamic envelope condition was discovered between the SIDE and the shield mounted on the ALSEP for protection of the SIDE during deployment. To correct this

problem, a design change was incorporated on Qual S and the Flight Models to (1) remove a portion of the shield where the interference occurred and (2) add a tie down to the sub-pallet holding the SIDE in an attempt to reduce the dynamic excursion of the SIDE assembly. It was expected that these fixes would correct the problem encountered in the Prototype tests and that revisions in the design of the SIDE itself would not be required. Also, the prototype SIDE weight and c. g. were not within the original ICS limits; however, it was expected that the fixes described would permit this to be accommodated.

An informal test readiness review was held at BxA on 1 December 1967 in preparation for the first system level thermal vacuum test. Representation from MSC and Bellcom participated.

By 4 December all procedures including handling, deployment, operations and contingencies were reviewed and approved. The system was deployed in the chamber on 5 December and the ambient IST was run on the following day. The lunar environment simulated conditions involved power activation, 24 hours lunar noon, and 24 hours lunar night.

The thermal vacuum test was completed on 21 December. No significant problems occurred on the central station, RTG nor System Test Set. The SWS experiment malfunctioned on initial turn-on and failed in turn-on on all subsequent tries. During the lunar day period one leg of the SIDE collapsed, toppling the instrument over on its side. Also, the high voltage turn-on of the SIDE caused its circuit breakers to open in the central station PDU which, in turn, commanded the experiment to stand-by mode.

The thermal simulation for the PSE seemed to be unsatisfactory. The high thermal losses in the sensor exciter cable inhibited reaching thermal equilibrium both at lunar noon and lunar night conditions.

Chamber pump-down to less than 5×10^{-6} TORR was reached at 10 a. m. December 15, 1967. The vacuum IST started at 4:00 pm, 15 December 1967 and was complete at 8:30 am, 16 December 1967 with the following results:

SWS data would not come on when POWER ON command was sent; command was sent 11 times - no response. Later during Environmental Reference Test, SWE was turned OFF, Temperature reached 42°F and a turn-on tried again, no response.

SIDE, PSE, and LSM operated similarly as in the ambient IST when no major unknown problems were revealed. Central Station performance was satisfactory.

Cool-down was started upon completion of this IST. Cold wall and lunar surface reached equilibrium in late afternoon (12/16/67) and radiometer stabilization about 9:00 pm. Environmental reference test was completed and warm-up for Lunar Morning turn-on started at 10:00 pm 16 December 1967.

Lunar morning turn-on stabilization was achieved early Sunday morning (Dec. 17) and turn-on started at 6:30 am. The IPU was turned on at 6:50 am and Central Station came on at 7:42 am. Full power was achieved at approximately 8:30 am. LSM and PSE experiments were turned ON, SWE remained at Power Standby and problems were encountered with SIDE. From 8:30 am until 11:00 am, each time SIDE Hi-Voltage OFF commands were sent, SIDE would draw too much current and kick off its circuit breaker. Problem was solved by warming-up SIDE with its IR Array, causing the SIDE heater to cycle off thereby allowing the Hi-Voltage - OFF command (which also blows dust covers) to get thru without an excessive current drain.

Warm-up for Lunar noon IST Test started at approximately noon on Sunday 17 December 1967.

At approximately 10:40 pm on 17 December 1967 one of the SIDE legs collapsed, and the SIDE experiment fell on its side. Since that occurrence, all SIDE temperatures were monitored every 15 minutes. At 7:47 am SIDE temp. reached critical level (+80°C) and the experiment was turned off.

The Lunar Noon IST commenced 19 December 1967 at 1:30 pm with SIDE turned OFF. SIDE was turned on approximately 3:30 pm. During the SIDE test the -3.5kv supply intermittently switched off, commanding off the -4.5kv, and causing the experiment to ripple-off. SIDE was turned off immediately after the IST to minimize overheating.

The LSM was tested next. During LSM testing the Z - sensor failed to flip in Y site survey.

The PSE was tested last. The temperature of the lunar surface was raised in steps from 40°F to 110°F. This was necessary to achieve PSE internal operating temperature within the time constraints for thermal equilibrium. The PSE section of the IST was performed satisfactorily.

The lunar noon IST was completed at 4:00 am 19 December 1967. Some radiometer checks were performed to measure incident radiation on the LSM.

Following these tests, the thermal/vacuum chamber was returned to ambient at 0800 on 21 December 1967. An inspection crew consisting of the Bendix Test Conductor, the NASA/ MSC Test Manager, Quality, DCAS and several Bendix Project Engineers entered the chamber to determine if any physical damage resulted from test. It was determined that the fracture of a nylon bolt caused the SIDE leg to collapse and, consequently, the experiment to tip over. No other unusual conditions were observed. Following this inspection, an ambient IST was performed with no unexpected results. The subsystems were then removed from the chamber. A partial PIA test was conducted on the SWS to determine if the experiment turn-on problem still existed when the experiment was connected to the ETS. The same discrepancy was noted.

The SWS and LSM were returned to their respective suppliers and the SIDE was returned to Bendix Bonded Stores. The SIDE was subsequently picked by the PI's representative and returned to Rice University. A series of test debriefing sessions were held during the first week in January. A test review was held with MSC representatives and a Test Result Summary was published as ATM-729.

Pallet I was disassembled for inspection of data components, harness, and so on. No discrepancies were noted. The harness modifications required to support the MSFN S-band compatibility tests were completed and the central station revalidated per procedure ATP-097. This test was completed and the prototype Central Station and required support hardware was prepared for shipment to MSC on 19 January 1968.

The only problem encountered during the MSFN compatibility testing at MSC was an apparent intermittent shift in sensitivity which was reflected in the signal to noise ratio. A diagnostic investigation was initiated in an attempt to isolate the cause of the variations. Bit error rate tests were run on both Uplink and Downlink channels.

Upon conclusion of the MSFN tests, the Central Station electronics was returned to Bendix and the components removed from the thermal plate. Voltage profile tests were performed successfully on the command decoder. The processor was submitted for modification to configuration C. The remaining components were subjected to voltage profile tests, and modifications, as required, were made to permit integration into the Proto C Central Station.

4.2.2.2 QUALIFICATION MODEL A

The qualification model was in fabrication and the initial phases of assembly when the program re-direction was received in May 1967. Fabrication of electronic components for this model was continued, although at a reduced effort for economy reasons. Work was stopped on the qual structural components pending resolution of the best approach to incorporation of the LM interface change, which was resolved on 21 July.

The SWS was received on 28 September and completed Mass Properties PIA and EMI Tests. A number of discrepancies were discovered during these tests including weight, center of gravity, EMI out-of-tolerances and functional discrepancies - none of sufficient seriousness to prevent continuation of the test program.

Work on the Qualification model during September and October included assembly, pre-integration test, and integration of the Central Station electronics. Completion of qual Central Station integration was hampered by a number of problems including:

1. Differences between specified PCU performance and realizable performance. This resulted in additional trouble-shooting and analysis, improvements in the SN-3, PCU, replacement of the SN-2 PCU by the SN-3 PCU and re-work of the SN-2 PCU. In addition, Bendix requested an appropriate Exhibit B change to recognize the basic performance achievable within existing constraints.
2. Difficulties encountered in PDU operation required replacement of the SN-3 PDU by the SN-4 PDU and re-work of the SN-3 PDU. The problems were in the receiver current breaker.
3. Failure of the 90-Channel Multiplexer Converter. This was replaced with the qual back-up unit and returned to Dynatronics for repair and failure analysis.
4. Re-work required on the Central Station Harness to provide acceptable terminal board connections and protection of these connections. Because of changes in this harness and re-work required to improve the lacing and tie-down, enough connections were damaged and stressed that a complete re-work of the terminal connections was judged desirable to obtain necessary confidence in passing qual tests.

5. Test procedures required substantial revision due to design changes between proto and qual as well as due to difficulties encountered in the qual data subsystem integration itself.

The integration and check-out of the Qual A Central Station electronics was completed and final mechanical assembly of the Qual A Subpackage No. 1 was begun 1 November.

The integration of the first qualification model experiment, the Solar Wind Spectrometer, was completed successfully on 7 November. The Passive Seismic Experiment Qual Model was delivered to Bendix on 5 October. During PIA an electrical malfunction occurred which could not be isolated. The unit was returned to Teledyne and the problem was isolated to the ETS used at Bendix. This was re-worked and the PSE returned to BxA. The PIA was then completed successfully and the experiment was put through Mass Properties and EMI tests. On 28 October, the PSE was found to be losing caging pressure. The unit was returned to Teledyne and repaired and returned to Bendix on 14 November.

The Passive Seismic SN-01 sensor was returned to Teledyne following an inadvertent actuation of its uncaging mechanism at the last step of its PIA test at Bendix on 15 November. The instrument was re-caged and exhaustive tests run to isolate the cause of the actuation. These tests did not unequivocally define the cause; however, they revealed some design and test set-up conditions which were corrected to reduce the probability of a recurrence of the actuation. The sensor assembly was returned to Bendix on 21 December.

The Central Station was transferred to manufacturing on 1 December for completion of the Qual A Subpackage 1 assembly. A PIA on the power dump loads was conducted on 20 December.

A validation test of pallet I had complete Central Station electronics installed and was performed per procedure 2333047 without the PSE sensor. Two series of resistance checks were performed to check the Central Station interface into the PSE lines. The validation was completed 17 January 1968.

At this point, the Qual "A" model was disassembled and the structure replaced with a new structure (Qual S) which included modifications of the ALSEP/LM interface as well as a revised LSM interface. This structure was integrated with the Qual A Central Station electronics and experiments.

This unit was called the Consolidated Qualification Model (Qual SA).

4.2.2.3 CONSOLIDATED QUALIFICATION MODEL (QUAL SA)

The Central Station was mated to the primary structure and thermal bag in January 1968. Subsequent testing disclosed an electrical short in the power dump resistor panel, which was reworked, and an apparent connector problem which disappeared upon retest after remating. A SIDE integration test was then performed, with no major discrepancies. During repeat of the post-assembly verification test (2333047), the experiments changed status when the PCU's were switched. An abnormal command sequence accounted for the problem.

The Post-Assembly Verification Test (2333047) was repeated in February with the Central Station in the primary structure. Subpackage 1 was then completely built up (less Boydbolts).

A leak test and abbreviated PIA were performed on the IPU Model 15.

A PIA and Experiment Integration Test were performed on the Solar Wind Experiment SN6. During integration testing, a SWS failure was encountered and the experiment was returned to JPL for repair. SWS SN5 was integrated successfully and, after return from JPL, SWS SN6 was successfully integrated.

A PIA and integration of the Lunar Surface Magnetometer were successfully completed.

The Qualification Test Readiness Review was held at Bendix on February 27 through March 1. The agenda include review by MSC representatives and Principal Investigators with their Bendix counterparts covering the state of readiness to begin the Acceptance and Qualification Tests for the ALSEP Qual SA model. The concluding session of the QTRR consisted of review and the dispositioning of the NASA and Principal Investigator's "Request For Change " (RFC's) chits.

The Integration Systems Test (per procedure 2333034) was started on 15 March 1968. On Sunday, 17 March, the NASA representative presented several equipment and procedural contingencies which were identified as mandatory for compliance before continuing the test. The mutual resolution of these items allowed the test to continue on Wednesday, 20 March 1968.

The ALSEP hardware performed satisfactorily during all phases of the tests listed below. The major difficulties encountered were involved with test procedures and parameter limits in the System Test Set software.

<u>Test Procedure</u>	<u>Title</u>	<u>Date</u>
2333034	Initial IST	25 March
2333060	Crosstalk	29 March
2333087	System EMI	4 April
2337925	Central Station Power Dissipation	5 April
2337940	Vibration Subpackage 1	9 April
2337941	Vibration Subpackage 1	12 April
2337938	Mass Properties Subpackage 1	19 April
2333034	Post Vibration IST	22 April
2338178	Deployed Magnetic Properties Sub- package 1	23 April

The ALSEP System thermal vacuum test was started and proceeded satisfactorily through ambient IST, pump-down, and lunar morning IST. The chamber environment was stabilizing at lunar noon conditions when an emergency chamber shutdown occurred on 17 May. The cause of the shutdown was isolated to a fault in the environmental facilities; a short that occurred between the hot line of an IR array and the cooling line of a radiometer loop. This shorting action caused a puncture in the cooling loop line which permitted water to be expelled into the chamber. An investigation of the occurrence and corrective procedures were accomplished. The status of the entire system was verified by retest at ambient conditions. The Central Station, LSM, PSE, and SIDE experiments suffered no detrimental effects from the shutdown. The SWS was returned to JPL for retest since arcing occurred as the pressure increased. The JPL tests indicated that the SWS was in good condition. The PSE thermal shroud was damaged by overheating of the top surface in an attempt to simulate a degraded surface condition. The shroud was replaced before tests were resumed. The ALSEP system was reintegrated and the thermal vacuum test was resumed on 29 May 1968, with a return to lunar noon conditions and a continuation of the test from the point of the original emergency situation. The Lunar Noon, Lunar Night, and Post-Thermal Vacuum IST's were successfully completed. The Central Station and RTG completed the tests with near faultless performance. However, the following discrepancies were encountered in experiment performance:

- PSE - Uncaged during transition from lunar noon to lunar night; performance otherwise was normal.
- LSM - Encountered a mechanical problem associated with Y axis sensor flipping; otherwise performance was normal.

SWS - Dust cover would not release while heater was activated and turn on transient with heaters on was excessive, which caused PDU circuit breakers to be blown; other functions were normal.

SIDE - Dust cover would not release due to an apparent mechanical hangup and heater inhibit circuit was not incorporated in Qual SA; otherwise SIDE functioned normally.

The cause of the PSE uncage in sensor SN-03 was isolated to a poor solder joint in pneumatic caging system, and the unit was repaired. However, shortly after pneumatic system repair, the sensor failed its PIA test because of a faulty transformer. The sensor required complete disassembly, reassembly, and test to repair the fault. To maintain the Qual schedule, PSE sensor SN-02 was replaced with SN-03 and tests were continued.

The LSM was returned to ARC for repair. The mechanical fault did not reoccur during ambient testing upon return to BxA.

The SWS was returned to JPL and a modification incorporated to eliminate the excessive turn-on transient problem.

The SIDE was returned to vendor for incorporation of the heater inhibit feature.

Upon return of all experiments, S/Ps 1 and 2 were stowed for performance of Stowed Magnetic Properties Tests. The maximum permed (to 25 gauss along three orthogonal) and depermed fields for S/Ps 1 and 2 were permed at 2.4 and 3.75 gammas at 10 feet, and depermed 2.1 and 3.7 gammas at 10 feet, respectively. These values are well below the allowable field of 10 gammas at 10 feet at frequencies less than 30 Hz.

The Qual SA S/P 2 weight was found to be 102.6 pounds. The Qual SA S/P 1 weight test made on 17 April 1968 showed a weight of 120.9 pounds, the combined weight for Qual SA Supackages 1 and 2 was 223.5 pounds. Both packages were well within their center-of-gravity requirements.

These tests completed the acceptance test series on the qualification model.

The Subpackage 1 Design Limit Vibration tests were conducted on 25-27 June in the following manner; the subpackage was mounted on the vibration fixture and vibrated along one axis; then the subpackage was removed from the vibration fixture and an abbreviated Integrated System Test (IST) was performed with the subpackage in the stowed configuration. This procedure was followed for each of the three axes of the vibration test. No significant failures were noted during the testing.

Subpackage 2 Design Limit Vibration tests were conducted on 20-24 June in a similar manner; i. e., vibration along one axis with a modified SIDE PIA and RTG functional checks performed between each of the three axes of vibration.

Failures noted during the test included a lens falling out of the surveying instrument and failure of the ALHT locking pin. The ALHT mounting was subsequently redesigned and the surveying instrument was redesigned and qualified by MSC.

During shock testing of Subpackages 1 and 2, conducted on 28-29 June, no failures were encountered during shock test nor in the abbreviated IST, SIDE PIA or RTG continuity checks performed after the shock test.

Acceleration tests on Subpackages 1 and 2 were performed in Bendix Mishawaka, Indiana facility on 2 July. No failures were noted. After completion of the acceleration tests, an abbreviated IST, SWS vacuum PIA, complete SIDE PIA, LSM PIA in the flux tanks, and RTG functional checks were performed with no failures encountered.

The Mission Simulation thermal vacuum test was successfully completed on 7 August 1968. The time sequence of the test was as follows:

Commencement of chamber pump-down	1330 on 13 July
ALSEP turn-on	1250 on 14 July
SIDE turn-on	1430 on 16 July
Morning transition IST	16 and 17 July
Obtain lunar noon conditions	2250 on 17 July
Lunar noon IST	19 and 20 July
Start decrease from lunar noon condition	0700 on 22 July
Sunset transition IST	27 July
Sunset	0320 on 27 July
Obtain lunar night conditions	30 July
Lunar night IST	1 August
Sunrise	0120 on 7 August
Sunrise transition IST	6 and 7 August

The test was highly successful, in general, with all subsystems functioning well.

Central Station electronics performance was good throughout the test with the exception of an apparent intermittent temperature dependent frequency shift in transmitter B. This malfunction occurred twice early in the test and cleared upon turning the transmitter off and then back on again. The Central Station thermal control system operated as anticipated. The thermal plate attained a maximum temperature of about 104°F under lunar day (lunar surface at 250°F) and minimum of about 3°F under lunar night (surface at -300°F) conditions. No problems with paint chipping occurred during this test or any other Qual Model thermal vacuum test.

The RTG performance was excellent throughout the test, providing an average of about 68.6 watts electrical output with 1465 watts thermal input.

The LSM and SWS experiments operated well. LSM experienced a Y-axis flip problem which cleared itself. The magnetometer electronics temperatures went lower than anticipated during night conditions, but the LSM continued to operate

satisfactorily. The SWS experienced two problems. Noise appeared on SWS science data when the IR lamps were turned on. This noise was later proved to be due to ground loop from the 14 x 14 foot lunar surface through SWS chassis to signal return. On future tests, the loop will be eliminated by electrically insulating the SWS chassis from the simulated lunar surface. The SWS also exhibited a temperature dependent modulation of the science data from some of its sensors. This modulation was believed due to a mechanical oscillation of the sensor grids. The SWS thermal control system operation was very satisfactory.

The PSE electrical performance was good throughout the test with one exception: during lunar day conditions, the sensor automatic thermal controller circuit apparently malfunctioned and a temperature rise of 2°F per hour was observed. This rate was larger than anticipated under the conditions and indicated that the thermal controller circuit was on continuously. The controller circuit operated normally after being commanded to manual and back to automatic control. A significant failure occurred in the caging system of the PSE during the transition from lunar day to lunar night. A leak developed in the caging system, starting on 23 July, and the pressure slowly decreased until the seismometer uncaged six to eight days later. The PSE continued to operate satisfactorily electrically during and after uncaging. Inspection of the seismometer at completion of the tests showed that the uncaging fault was apparently caused by a defective joint on a bellows assembly.

The SIDE experiment overall electrical and thermal performance was good throughout the test. SIDE experienced an apparent temperature sensitive channel-tron high voltage regulator fault during night-to-day and day-to-night transitions. Examination of the experiment after the test disclosed intermittent contacts in the voltage regulator feedback circuit. A change had been made in "blivet" interwiring of SIDE which eliminated the cause of this intermittent in the voltage regulator circuits in models subsequent to the Qual.

The Design Limit Thermal Vacuum Test was a continuation of the Mission Simulation Test in which ALSEP was exposed to more severe lunar noon conditions (lunar surface at +280°F and solar irradiation 1.25 to 2.0 suns). On August 8, the lunar noon conditions had been established for about one day and the Central Station and experiments were within a few degrees of their noon equilibrium temperatures when a chamber fault occurred. A glass vacuum gauge on a vacuum line between a high volume mechanical vacuum pump and the oil diffusion pumps employed. The pressure rose from 2×10^{-7} torr to approximately one torr in two minutes. The fault was corrected by inserting a new vacuum gauge in line; and the mechanical vacuum pumps continued to maintain vacuum. Within 30 seconds of the fault, the test conductor supervisor instructed the test conductor to turn SWS and SIDE to standby and an attempt to turn these experiments off was made immediately. However, because the test crew was in the normal process of changing STS computer software at the time, the commands were not executed until the completion of the executive program load. Thus, the commands were not actually sent until 11 minutes after chamber fault. During this period the SIDE malfunctioned, apparently drew excessive current, and went into standby mode automatically. The SWS programmer apparently "locked up" and stayed in the same state

until commanded to standb. By 14 minutes after the fault, the entire ALSEP system including the Central Station was turned off and the RTG thermal input power was decreased.

All the cold walls in the chamber were covered with frost; however, no signs of frost appeared on the warmer experiments or the Central Station. The frost was sublimated off the cold walls by increasing the cold-wall temperatures and maintaining vacuum with the high volume mechanical pumps. Visual examination of the cold walls from outside the chamber showed noticeable signs of diffusion oil carried in by the air passing through the oil diffusion pumps. Fourteen hours after the first failure, pictures were being taken of an apparent oil film on the cold walls while vacuum was being maintained at about 10^{-2} torr when a second unrelated fault occurred. A 12-inch diameter glass window through which a photo flood was being projected imploded and the vacuum chamber returned to near ambient pressure within a few seconds.

Damage assessment studies were made of all the Qual SA equipment. The SIDE and SWS data indicated that their high voltages apparently arced during the first implosion. A PIA performed after removal from chamber showed no apparent damage to SWS. However, the SIDE experiment experienced failures in several circuits due to the apparent arc. The remainder of the system appeared undamaged by the first implosion. The second implosion scattered glass and insulation throughout the chamber. Fortunately, no ALSEP equipments were hit by large pieces of flying glass. The equipments on the 14 by 14 foot lunar surface were protected by two vertical cryo-panels in the front part of the chamber. The only significant physical damage to ALSEP equipments other than PSE consisted of hundreds of small indentations in the forward Central Station thermal curtain; probably caused by small glass fragments. The PSE experiment sensor was situated directly in front of the window which imploded and was swept to a back corner of the PSE surface. The PSE thermal shroud was severely damaged and both flat conductor cables were ripped off. Initial examination of the interior of the PSE sensor disclosed little damage, considering the seismometer was uncaged. Slight bowing of some flexure wires and scratches on the exterior of the sensor were noted. All equipment in the chamber was covered with a slight coating of diffusion pump oil.

The Qualification Assessment Review (QAR) was conducted by NASA/MSC at Bendix Aerospace Systems Division on 14 through 16 August 1968. The result of the QAR was the formal certification of qualification of the Qual SA model, with 32 open items and a decision not to resume design limit thermal vacuum tests on Qual SA. Twenty of these open items required BxA action to close out, and the remaining 12 required MSC/PI action.

As a result of QAR, all system level testing on Qual SA was complete and the experiments and RTG were returned to PI's and vendors as requested by MSC. Subsystem level testing was performed on Central Station components and experiments in order to clear up open items. All open items were cleared in May 1969, closing out the Qual SA test phase.

Qual SA was allocated to the build up of an ALSEP for the MSFN check. After build-up, the model was tested and delivered to KSC. The Receiving Inspection function performed at KSC on the MSFN Qual SA and STS resulted in 12 minor DR's which were dispositioned "Use as Is". Qual SA-STs verification followed and the system was declared ready for "dry run" SIT with MILA on 10 April.

The KSC/MSc/BxA post-test meeting of the Qual SA MSFN short command engineering test at KSC concluded that the test successfully met all objectives, and therefore cancelled the formal test scheduled for 1 May.

Tests were conducted in Ann Arbor with the ALSEP Qual SA (MSFN Test Model) and the System Test Set to investigate the "False CV 177" anomaly discovered during interface testing at KSC with the Manned Space Flight Network.

1. These tests established that converting the System Test Set to filler "ones" (Between commands) instead of "zeros" reproduced the anomaly.
2. Using an alternating filler pattern of "zeros" and "ones" caused the anomaly to show up as "False CV 052" and "False CV 125". The fact that Command 052 was a valid operational command and was not executed shows that this anomaly was not a potentially hazardous condition.
3. The Anomaly did not appear when ALSEP was operating at a low bit rate, only at normal bit rate.
4. Analysis of circuit schematics indicated a possible cause in the signal pulse at the end of readout of a normal Command Verification Word. This pulse may, at random times, be inadequate to drive the reset gates.

The ALSEP/MSFN/MCC compatibility test was conducted from KSC using the MSFN Test Model (Qual SA) and the DVT Model of the PSE Sensor with earth masses. A preliminary test on June 17, 1969 verified that the hardware was ready and validated the test procedure, TCP 2338735. On June 20 the live test was started with an RF link to the MILA ground station of the MSFN and through the network (via Goddard Space Flight Center) to the Mission Control Center (MCC) in Houston. Commands were sent from Houston and transmitted from MILA to ALSEP. Telemetry data from ALSEP was received at MILA, and forwarded to Houston where it was processed and displayed in the MCC. This was the first closed-loop test of ALSEP with the complete ground complex. The test was successful in verifying command and telemetry compatibility. The PSE was uncaged during the test and for more than 15 hours seismic data was read out on displays in Houston.

With MSC/LSPO approval, a deviation to the test procedure added a "dual uplink" test. In this test, signals were transmitted to ALSEP simultaneously from the STS and the MILA station. This simulated a possible lunar operation "handover" condition where one ground station did not shut down its transmitter before the next station turned on its transmitter. The test verified the "dual uplink" was not an acceptable mode of operation. False commands were indicated in the ALSEP command verification word at a rate of approximately ten per minute of operation. Only ten percent indicated normal parity (check of command and its complement)

and most of these were invalid commands. However, in a test covering at least 30 minutes, one false command was executed by ALSEP as observed in the house-keeping telemetry. A subsequent meeting (June 24) at MSC resulted in an action item on LSPO to develop a procedural solution with the network operations people. A gap of at least one minute was to be provided (break-before-make) during station handovers.

4.2.2.4 ARRAY A FLIGHT 1

The Flight 1 model was in various stages of component fabrication when the program re-direction was received on 19 May 1967. The hardware was re-kitted and placed in bonded stores until fabrication and assembly was re-initiated in November.

All components had been through PIA testing in March 1968, and burn-in testing of transmitters and receivers had been completed successfully. The essential electrical harness was mounted on the thermal plate and the PDU SN-5 installed on the thermal plate. The Central Station integration procedure was reviewed by the Flight 1 test conductor, and it was forwarded to MSC for review and approval on 21 March 1968.

Flight 1 Central Station integration (to procedure 2333011) was completed in April. Subsequent to build-up, the transmitters were replaced with those previously designated for Flight 2 after rework to include a more reliable transistor.

The Reserve Power Resistance Measurement Test, (procedure 2337944) was run on the Central Station and Primary Structure assemblies. PSE Central Electronics, SN-3, was integrated with the Central Station (to procedure 2333033), using Sensor SN-1 for test purposes. Subsequent to this integration, the PSE SN-4 Sensor and Central Electronics were received and the PIA test was completed. Both the SN-4 Sensor and the SN-4 Central Electronics were then integrated with the Central Station. Consequently, PSE Flight 1 hardware was the SN-4 Sensor and the SN-4 Central Electronics, instead of the previously planned combination of the SN-4 Sensor and the SN-3 Central Electronics.

The Flight 1 Primary Structure was complete in April. The sunshield was complete except for installation of the Dust Detector.

Flight 1 SWS (SN-8) was received and completed PIA and integration with the Central Station the week of 29 April 1968. Flight 1 SIDE/CCGE delivery was on 29 April; PIA and integration was the week of 29 April. The timer, which was integrated into the Central Station was replaced with a unit having a different lubricant to eliminate potential failure. The replacement timer underwent a continuous 5-day incoming inspection test; it was then integrated and tested in the Central Station late in the week of 29 April. Subpackage 1 completed final assembly into the deployed configuration, and the Central Station Post Assembly Verification test (procedure 2333047) was run early in the week of 6 May. The RTG, and spare, were received.

The Flight Test Readiness Review for Flight 1 was held 9 and 10 May 1968, and approval was received to proceed with formal acceptance testing.

The LSM was received and PIA tested on 24 May. Subsequently, it was integrated and an IST performed by way of a continuous test using selected sections of test using selected sections of test procedures (TPs) 2333033 (Experiment Integration) and 2333034 (Ambient IST). Subpackage 1 was then reconfigured from the deployed to the stowed condition. In parallel with S/P 1 stowage, a troubleshooting test on the LSM was performed to establish the cause of abnormal flipping of the Y sensor during integration. It was believed that mechanical constraints in the B configuration flux tanks caused this problem and that it would never occur when the LSM booms are fully deployed. There was no re-occurrence in subsequent tests, either in the flux tanks or fully deployed. During S/P 1 stowage, JPL reworked the SWS at BxA to incorporate a change in the mounting of the thermal bag, and bonded screws in the sensor assembly to prohibit their backing out as occurred on the Qual model during Qual SA vibration. A PIA was performed on the SWS after this rework. The LSM, PSE and SWS were then mounted on Subpackage 1.

Acceptance tests were then performed in the following order on Subpackage 1: SP1 Mass Properties (2337938); Central Station Timer Start Up in STOP mode (2338193); SP1 Vibration Acceptance (2338181); Stowed Magnetic Properties (2333049); Tumble Test (2338092); and Post Dynamic Test - Boydbolt Verification (2338603). During vibration, the LSM cable reel rotated due to insufficient friction between the reel and reel retainer bracket on the sunshield. A design fix was incorporated, that portion of the test was repeated and the vibration test then completed. During vibration, two of the sunshield retaining Boydbolts lost preload. The cause was attributed to improper installation of the bolts.

Subpackage 2 was completed and the following acceptance tests were performed: SP 2 Mass Properties (2337939); SP 2 Vibration Acceptance (2338182); Stowed Magnetic Properties (2333049); Tumble Test (2338192), and Post Dynamic Test - Boydbolt Verification (2338603). During vibration, two S/P 2 Boydbolts lost preload; cause was attributed to improper installation. During vibration, a tool retaining bracket of the ALHT loosened. Cause was attributed to a defective fastener. The part was replaced and the test continued. (The Qual model ALHT was used to load the pallet for Flight 1 acceptance test).

Subsequent to this series of tests, the Generator Assembly Leak Test (2333056) and Generator Assembly Post-Environmental Functional Test (2333059) were performed on the RTG. The SIDE was placed in the 5 x 8 chamber for pre-thermal vacuum outgassing in accordance with the SIDE T/V Soak procedure (2337945).

After completion of Subpackage 1 stowed tests, a decision was made to return the SWS to JPL for incorporation of a design change to reduce the turn-on transient. This change was to eliminate the inability to turn on SWS during lunar morning or night (while heater is on) as experienced during Qual SA thermal vacuum test. Prior to return to JPL, an ambient PIA was performed. Upon return, a vacuum PIA was performed.

Subpackage 1 was placed in the deployed configuration subsequent to the stowed series of tests.

The flight equipment was deployed in the Space Simulation chamber, the open door IST was completed on 22 June, and chamber pump-down started on 23 June. The open door IST was interrupted to solve two major problems: (1) the shorting plug design was modified to disconnect two RTG temperature sensors from the multiplexer, thereby eliminating a potential failure mode whereby multiple channels of housekeeping data would be lost if the sensors were to short or open; and (2) the LSM cable was damaged during ALSEP deployment in the chamber. It was suspected that this may have been the cause of a loss of data from the LSM at initial turn-on of LSM, as well as possible damage to circuitry within LSM which provides experiment offset status and offset address status information. The most likely causes were electrical damage due to cable shorting or mechanical damage during vibration. The cable was replaced and subsystem tests showed that the experiment reacted normally to all commands and scientific data was being imparted. The decision was therefore, made to proceed with the thermal vacuum test.

Chamber pump-down started on 23 June, and the normal cycle of the thermal vacuum test was completed; i. e., lunar night (for radiometer calibration), lunar morning IST, lunar noon IST and lunar night IST. During these tests, three major problems were encountered: (1) thermal coatings on the Subpackage 1 sunshield and on one side of the Primary Structure lost adhesion and cracked during the cycle from ambient-lunar night-lunar morning; (2) the PSE would not respond to its uncage command during the lunar morning IST; and (3) high voltage gassing of the experiment at that time.

An additional lunar noon cycle was added to the test, subsequent to lunar night and prior to return to ambient. This additional test cycle established that: (1) the thermal coatings on the Sunshield and Primary Structure would remain physically intact during additional thermal cycling and that temperatures within the Central Station remained normal throughout the complete noon-night-noon cycle; (2) PSE uncage circuitry within the Central Station was temperature sensitive and confirmed the temperature at which start of normal operation was observed in the previous lunar morning-to-noon excursion (normal operation established when the PSE electronics exceeds 30°F; this temperature will be exceeded at the time of PSE uncaging after lunar deployment); and (3) the SIDE performed normally under lunar noon conditions after sufficient time elapsed in the chamber to permit complete outgassing.

The complete thermal vacuum test cycle from door closure to opening was nine days. Subsequent to return to ambient and opening the chamber door, an open door IST, including a functional test of the Dust Detector, was performed. Since the LSM sensors were in a saturated condition during this test, a PIA with the LSM in its flux tanks was performed after the open door IST to assure normality of the scientific data output. A leak test on the RTG and a VSWR test on the antenna were performed after the thermal vacuum test.

Upon removal from the chamber, Subpackage 1 was partially disassembled; the Sunshield and Primary Structure were stripped and repainted, using a different lot number primer and thermal coating and preparing the metal surfaces by removing all chemical treatments (e. g., alodyne) and by roughing. Tests on sample coating coupons were performed to establish the exact cause of failure of the original coatings; it was believed that insufficient cure time had elapsed prior to subjecting the surfaces to the cold lunar night condition. After recoating and re-assembly of Subpackage 1, a complete functional verification of the station was performed.

A Customer Acceptance Review, Phase 1, was conducted by NASA/MSC at Bendix Aerospace Systems Division on 8 through 9 July 1968. This review established open items requiring resolution prior to Government acceptance of the hardware. Phase 2 of the Customer Acceptance Review was conducted by NASA/MSC on 15 July 1968 at BxA; and on that date ALSEP Flight 1, Subpackages 1 and 2 were formally accepted with the signing of form DD 250.

Flight 1 experiments were shipped from BxA to the PI or vendor facilities for recalibration late in July. Some of the open items from the Customer Acceptance Review, Phase II, which required BxA action were completed. These items were:

1. DR 0491 - Ship short of 4 SIDE Boydbolts - Closed 15 August.
2. DR 0498 - Change in SIDE guide cup height, reperform release test with UHT - Closed 15 August.
3. DR 0493 - Modification of Carry Bar, reperform fit test with SP 2 stowage fitting - Closed 15 August.
- 4&5 DR 0130 and DR 0295 - PSE uncage circuit temperature sensitivity - Tests at Teledyne on a PSE Central Station electronics unit (S/N 5) established that the Flight 1 hardware condition was not the result of circuit or component degradation; therefore, operation of the uncage circuit overall temperatures to be encountered during uncaging on the lunar surface was assured. BxA provided a final report to MSC documenting test results and circuit analyses on 15 September.
6. DR 0426 (PSE LaCoste spring suspension wire) - The PSE sensor S/N 4, was returned from Teledyne subsequent to rework and has undergone PIA test and integration with the Central Station. The DR was closed after completion of a visual inspection by BxA and the PI of the LaCoste spring/clamshell assembly during the week of 30 September.
7. Incorporation of CRD 55377, change in ALHT spherical mounting pin material from titanium to steel - Complete 15 August.
8. Incorporation of CRD 55416 and 55608, lanyard attachment between SIDE astronaut-mate connector and connector holding pip-pin - CRD 55608: increase in pip-pin hole in connector bracket completed 15 August; CRD 55416: attachment of lanyard will be made at time of stowage of SIDE to Subpackage 2 for delivery to KSC.

In September the S-13G thermal control surfaces of Subpackage 1 (primary structure, thermal plate and sunshield) were subjected to a 24-hour cure at 150°F by placing the subpackage in a Conrad chamber. This cure cycle was established,

as a result of extensive thermal/vacuum tests of coating coupons, to be the final corrective step to assure adhesion of Flight 1 coatings in a vacuum. Solar and infrared reflectance measurements were also made on Flight 1 surfaces. The α/ϵ of the S-13G coated surfaces and the aluminized mylar side curtains, although slightly in excess of the expected values, are within acceptable limits.

Subsequent to the coating cure cycle and reflectance measurements, functional verification of Subpackage 1 and PSE sensor integration were performed.

A majority of the Phase II, CARR open items were closed prior to the Phase III review held on 9 October 1968. The Flight 1 recalibration tests were rescheduled to remove, degrease and replace the Central Station timer.

The following items were open prior to the Phase III review:

1. Boydbolt loss of Pre-load
2. Subpackage 1 Overweight - A waiver was processed.
3. LSM Mechanical Interface
4. PSE Shroud Modification
5. Use of the RTG with Astronaut Shorting Plug - This item was included in the recalibration IST.
6. Measure of Radiated Power From the Antenna - Included in the recalibration test sequence.
7. Completion of Timer Reliability Tests
8. Reflectance Test - Required MSC approval of specification changes.
9. Missing Adapter from SIDE Ground Screen - Required removal from original ground screen.
10. PSE Caging System Rework.

At the conclusion of the Phase III review, the status was modified in the following manner. A dynamic test of the Boydbolts was scheduled as a result of the QAR. Rework of the E-2 DRT at Grumman to flight configuration was requested. The requirement for Reflectance tests was eliminated. It was suggested that the CRD format be modified to include an indication of effectivity on qualification status and acceptance testing. A method to document the number of times a given Essna nut is installed was requested. MSC requested that BxA review the advisability of performing Boydbolt torque tests at KSC.

PIA's were completed for the PSE, SWE and SIDE.

The RF Link Verification, KSC Timer Starting and MIST Tests were performed with the Subpackage 1 fully stowed except for the LSM and Antenna. During the RF Link Verification Tests, the final Antenna and LSM connections were made. All remaining tests, through stowage of the Antenna and LSM, were made without "breaking" these connections.

Receiving Inspection on the Flight 1 ALSEP Cask Assembly at KSC resulted in four DR's which did not constrain the C F on LM 6. Receiving Inspection on Subpack 1 and 2 resulted in five DR's on Subpack 1 and thirteen on Subpack 2.

The ALSEP Cask Assembly was satisfactorily fit checked to LM 6 and the C²F² completed on LM 6 also. Astronaut deployment of the Flight 1 subpackages was successfully accomplished on 25 April.

Restowage of ALSEP Subpackages 1 and 2 after all ALSEP Flight 1 Deployment action items were reviewed and closed-out with the Apollo 12 crew was completed by the end of April. The Flight 1 Fuel Cask Assembly was returned to Ann Arbor for scheduled work and was retained for incorporation of a gear box modification.

The ALSEP Flight 1 degaussing was completed, and a caging system pressure check was successfully completed on the Passive Seismic Experiment. This test was conducted every two weeks until launch.

The Subpackages 1 and 2 were successfully installed in LM 6 on 21 June and the subpackages were inspected by Astronaut Gibson prior to SEQ Bay closure on 22 June.

Incorporation of the PSE circular bubble level and Boom Ring modifications were completed, and the SEQ Bay door was closed and sealed by Grumman on 2 September. The final close-out was witnessed by astronauts Gibson and Bean.

Formal BxA/KSC review of Grumman's TCP-KL-10034 (Descent Stage ALSEP, MESA Inspections, Fit and Functional Checks and Formal Installation) for LM 6 (Apollo 12) was completed; all ALSEP inputs were properly incorporated.

The Flight 1 Boydbolt rework was completed in December, rework of the PSE Shroud Gnomon was begun (after qualification of the Qual SB gnomon) and the post calibration SIDE weight was determined.

The Flight 1 schedule for packaging for shipment to KSC was extended to provide additional time to complete the timer reliability tests, the LSM calibration and the PSE sensor caging rework. The Flight 2 LSM, S/N 4 and PSE Sensor, S/N 5, were transferred to Flight 1.

Reliability tests on the Central Station timer were completed in January 1969. Analysis of the timers was then completed at KSC. The Flight 1 timer was reworked and reintegrated successfully to the Central Station following the analysis. During this period, the SIDE rework not previously scheduled was completed. This effort was the result of analysis of the Flight 2 SIDE thermal vacuum tests.

Caging system rework on PSE Sensor S/N 5, including vibration, was successfully completed in February. The PSE gnomon was added to the shroud and the gnomon alignment calibration test was completed. The PIA of LSM S/N 6 and integration with the Central Station was completed.

Two SP #1 verification tests were conducted: one immediately following reassembly of SP #1 after timer replacement and the other following teardown and re-assembly necessitated by questionable thermal bag installation. The results of both tests were satisfactory.

Flight 1 was shipped to the Cape on 25 March 1969 after successfully completing all acceptance tests and incorporation of all design improvement modifications.

The tests and modifications performed are listed below:

1. PSE Sensor Mass Properties Test
2. LSM Mass Properties Test
3. Deployed IST
4. RTG Shorting Plug Positive Locking Modification
5. PSE Shroud Lanyard Addition
6. Dimensional Measurement of LSM Stowed on Subpackage #1
7. RF Link Verification Test
8. KSC Timer Starting Test
9. Modified IST (MIST - Subpackage #1 Stowed)
10. Measurement of Subpackage #1 and #2 Weight
11. Final Stowage of Subpackage #1 and #2
12. Lanyard Addition to Subpackage #1 and Booms and ALHT
13. Experiment and Subpackage Flight Preparation
14. Packaging for Shipment

The following Apollo 12 ALSEP subpackage preparations were on-the-pad early in October.

1. Removed magnetic recorders
2. Started Central Station Timer
3. Replaced pip pins
4. Completed ALHT Slip (GFE) modification
5. Removed PSE lock-out connection, performed PSE pressure check, and vented the PSE sensor.

A fit check of the instrument staff (part of the GFE ALHT) to two camera handles on the pad showed hardware did not fit. The instrument staff was transferred to the Hyper Building where it was satisfactorily fit checked to three other camera handles. The instrument staff was reinstalled on the ALHT on 9 October.

Final installation of the Flight 1 fuel cask on LM 6/Apollo 12 was completed on 21 October. The fuel cask was "flight ready" after clearance of eight outstanding DR's.

The Cask/Capsule Operational Review conducted at KSC resulted in the following BxA action items.

1. BxA required to provide feeler gages for Flight 1 and Spare cask assemblies to provide back-up for the Strain Gage Readout GSE.
2. BxA to provide real-time engineering support during the CDDT and Countdown to plot temperature and air flow velocities around the cask.

3. BxA to complete a detailed review of all operations performed by Grumman in the SLA after cask installation. The review was to preclude any actions detrimental to the cask installation or operation.

The IBM/NASA on-the-pad installation of the Apollo 12 cask cooling system was satisfactorily completed on 22 October.

Sandia performed installation and removal of the "hot" capsule in the Flight 1 cask during Apollo 12 CDDT. The "hot" capsule was satisfactorily removed on 28 October. A continuous recording of the ECS temperature flow, nozzle pressure, and cask temperature was accomplished during the 36-hour period that the "hot" capsule was installed in the cask. The cask cooling system functioned satisfactorily, and the cask temperature remained under 170°F throughout the CDDT.

The "feeler gages", required as back-up GSE to the Strain Gage Readout, for Flight 1 and Spare cask assemblies were received at KSC and satisfactorily fit checked to their respective hardware. Training and practice on the use of the feeler gage were provided to Sandia on 10 November.

The baroswitch check on the Flight 1 fuel cask was successfully completed on 6 November. This action closed out DR F1-CSK-008 which was the only open item on the fuel cask prior to the check. However, after completing the check the instrumentation wiring was visually inspected for possible damage due to air flow. At that time it was discovered that the standoff wires on the strain gage had apparently received an impact severing the wire close to the standoff on pin "C". In addition, the paint on the astroguard was scuffed. Two DR's were initiated. The disposition on the former was to use the back-up "feeler gage" instead of the Strain Gage Readout during the installation of the "hot" capsule. The disposition of the latter event was to "use as is" and both DR's were closed on 7 November.

Modification on the Flight 1 fuel cask specified in CRD 57428 was completed. This consisted of rotating the right hand lock tab and tension stud 180° to eliminate a possible interference between the lock tab and the wire assembly.

BxA personnel at KSC supported Sandia during the Apollo 12 "hot" capsule installation on 13 November 1969. Recording of cask cooling data started immediately after installation and continued until launch. The cask cooling system functioned satisfactorily, and the cask temperature remained under 160°F throughout the Countdown.

Apollo 12 was launched on 14 November 1969, and the ALSEP Array A Flight 1 System was deployed on the Moon in the eastern part of Oceanus Procellarum (Ocean of Storms) on 19 November 1969.

4.2.2.5 Array A Flight 2

Manufacture of the Power Distribution Unit, Power Converter Unit, Data Processor and Command Decoder was complete in April 1968. PIA test of these units was delayed awaiting free-up of subsystem test sets used to perform Proto C Central Station integration. .

The following Central Station components successfully passed pre-integration tests in May: Power Converter Unit, Power Distribution Unit, Command Decoder, Data Processor, Diplexer, Transmitters (2) and Receivers (2).

Test of the Central Station harness was completed early in June. Subsequently, all Central Station components were integrated per the Central Station Integration TP 2333011.

The PSE, SN 5 Sensor/SN 2 Electronics unit was received and PIA tested. The PSE was successfully integrated with the Central Station. Build up of the Central Station, primary structure and sunshield into Subpackage 1 in the deployed configuration started on 22 June, subsequent to PSE integration.

The SWS Flight 2 unit (SN 7) was returned to JPL for incorporation of a design change to reduce the turn-on transient when the experiment is cold and the heater is "on". This change was made to eliminate an inability to turn-on SWS at lunar morning during Qual SA thermal vacuum tests. The unit was then returned to BxA.

Tests on Flight 2 hardware performed in the following sequence:

1. PSE Mass Properties
2. SWS (SN 7) PIA and Mass Properties
3. SWS (SN 7) Integration
4. SIDE Integration
5. SWS (SN 9, replacement for SN 7) PIA
6. LSM PIA
7. SWS (SN 9) Integration
8. LSM Integration
9. RTG Leak and Acceptance Test
10. LSM and SWS (SN 9) Mass Properties.

The integration tests were performed with Subpackage 1 minus the Sunshield, Thermal Reflector and Side Curtains.

Thermal coating of the Flight 2 Sunshield was intentionally delayed to await determination of the probable cause of loss of adhesion of the Flight 1 coating and the establishment of a revised coating process. This resulted in a delay of approximately two weeks in starting the Acceptance Test program.

Acceptance testing of Flight 2 was begun on 5 August 1968, with the Central Station Power Dissipation Test (TP 2337925). During conduct of this test, components within the Central Station were subjected to an overvoltage condition due to loss of regulation in the PCU. This condition was the result of an error in the interconnection of test points on the junction box inserted between the PCU and the Power Dissipation Module for the power dissipation test.

Subpackage 1 was disassembled; PIA tests on the components uncovered damage to both transmitters which were replaced with spare units. All other Central Station components except the receiver (but including the PSE electronics) were subjected to hot and cold as well as ambient PIA tests in order to assure that the overvoltage condition had not degraded any electronics components. The receiver was replaced with a spare unit (even though it had passed an ambient PIA test) since facilities were not available for hot and cold PIA test of this RF component at BxA.

Subsequent to PIA tests of the components and their installation on the thermal plate and installation of the thermal bag, a functional verification test was performed (Secs. 6.4 and 6.5 of TP 2333033). Final assembly of Subpackage 1 into the deployed configuration was then completed again.

The Central Station Power Dissipation Test was rerun completely, and the Integrated System Test was started on 16 August.

On 20 August, while conducting the IST, the PSE science data was noted to be erratic. Investigation indicated a failure had occurred in the PSE Central Station electronics and, therefore, S/N 2 was replaced with S/N 6. During the same test, LSM status indicated both a flip and gimbal status discrepancy. The Z-sensor cable was off its pulley and the Y-sensor cable required adjustment.

Miscellaneous discrepancies occurring during the remainder of tests were:

1. S/P 1 Mass Properties measured 5.7 lbs overweight (based upon a specification weight of 115.0 lbs). The overweight value was comparable to that experienced with the Flight 1 and Qual models.
2. During Magnetic Properties test, a loose screw fell from the SIDE chassis. The screw was replaced prior to T/V test. A locking compound had not been employed because of anticipated recalibration after acceptance tests.
3. The stop block on the PSE cable failed during test setup; it was repaired prior to the T/V tests.
4. A screw backed out of the RTG shorting plug connector due to a manufacturing deficiency and was repaired prior to T/V test.
5. The SIDE leg was observed to be loose during deployment in the T/V chamber. This item repaired upon completion of the acceptance tests.

Verification test of the Space Simulation chamber in preparation for thermal vacuum testing was started on 17 September and completed on 19 September. Deployment of ALSEP and the pre-environmental IST were completed by 20 September.

The Lunar Morning turn-on for the T/V test was initiated on 25 September. The test progressed smoothly to completion on 3 October. During the test the following problems were encountered:

1. The timer pulses were not received correctly.
2. The SIDE-CCGE high voltage failed to turn on at Lunar Morning and Night but functioned normally at Lunar Noon.
3. Noise and a DC offset was noted on the PSE long period X-channel.
4. The PSE Uncage Status reset itself without command.

Upon completion of the test, troubleshooting revealed the one minute contacts of the timer had shorted. The timer was repaired, degreased and reintegrated with the Central Station during the Phase I review. Tests indicated no additional faults were present and were completed on 12 October.

The SIDE voltage problem required testing at Rice to determine the fault.

The two PSE problems were the result of:

1. Reducing the caging pressure to 50 lbs, which allowed slight movement of the masses.
2. PSE exciter cable insulation was punctured at the PSE Lunar surface, causing a ground loop; this in turn caused the uncage status to reset itself whenever it was armed.

All acceptance tests for Flight 2 were completed prior to the Phase I Customer Acceptance Readiness Review held on 10 and 11 October. The Phase II CARR was held on 15 October, and the DD 250 was reviewed and signed.

During the Phase I and II reviews, the following significant open items were identified:

- . Additional testing as identified-at the QAR on 8 October, was required to closeout the Boydbolt open items
- . Central Station timer reliability tests were not successfully completed
- . PSE caging system required rework, and was scheduled for completion by 2/2/69
- . LSM flip/gimbal cables required rework
- . SIDE-CCGE high voltage problem required investigation and repair.

The LSM, SIDE and SWE were returned to their respective manufacturers for calibration and/or rework.

During December 1968, the Flight 2 hardware was redesignated as follows:

1. The Central Station, less experiments, was transferred to EASEP.
2. The SP#2 with exception of the SIDE was transferred to Flight 4.
3. The PSE Sensor and LSM were transferred to Flight 1 with the corresponding Flight 1 experiments being designated spares.
4. The SIDE, SWE and remaining miscellaneous hardware were designated spares.

4.2.3 ARRAY B

4.2.3.1 PROTOTYPE B

The Prototype B model used Prototype C data subsystem components; consequently, Central Station build-up could not begin until completion of the Proto C test program. Manufacturing of the new harness was completed in June 1968.

The Proto C thermal plate was stripped of all components in July, and operation sheets were prepared to retrofit the thermal plate from Proto C to Proto B configuration. The Proto B harness test was completed. The PSE and CCGE experiments were available.

Central Station integration testing of the ALSEP Prototype B was completed in August. No significant problems were encountered.

The CPLEE experiment was sent to Rice University for testing prior to experiment integration.

The CPLEE was returned to Bendix from Rice University. The additional testing was completed successfully. PIA, Mass Properties and EMI tests were successfully completed on the CCGE.

The prototype Heat Flow Experiment electronics were retrofitted by Gulton and returned to Bendix. Mechanical assembly of the experiment was started in August 1968.

The experiments integration portion of Prototype B testing continued throughout September. The PSE experiment and the CCGE experiments were integrated with the Proto B Central Station. No significant problems were encountered. The acceptance PIA on the CPLEE experiment was completed and CPLEE was ready for integration with the Central Station.

Problems of possible damage to the 70 fine wires which interconnect the HFE electronics with the probes were encountered, and the DVT, prototype, and Qual Model HFE's were disassembled, the solder joints were inspected, and the units were repaired as necessary and potted.

The integration of the CPLEE S/N 2 with the Prototype B Central Station was completed on 1 October 1968. No problems were encountered with CPLEE hardware. Minor problems existing in STS computer programs were resolved.

HFE experiment integration occurred during 9 through 11 October, and the HFE experiment and Central Station operated without fault. However, the rise and fall times of the timing and command signals at the HFE interface were excessive; approximately 100 to 400 μ sec as opposed to interface specification values of 2 to 10 μ sec. The cause of the long rise and fall times was traced to large capacitor values in the HFE on the interface lines. Although the HFE operated properly under room ambient conditions, it was questionable that the experiment would

continue to function over temperature extremes. In addition, the HFE exhibited excessive high frequency noise on its +29 volt power lines. Thus, the HFE S/N 2 was returned to the subcontractor for substitution of smaller capacitors on timing lines and the incorporation of additional high frequency filtering on the +29 volt power line.

During the 11 to 17 October period, the Central Station assembly was integrated with the primary structure and built-up into a complete SP 1 configuration. Prior to build-up, a three-axis accelerometer was mounted on the thermal plate to monitor response of the thermal plate during vibration. This was the first time that an accelerometer was mounted directly to the thermal plate.

The Prototype B Program was redirected to effect conversion to a Qualification B Program.

4.2.3.2 QUALIFICATION B

The conversion of the Proto A structure to Proto B configuration and the completion of the Qual B sunshield proceeded in parallel with the Experiment Integration Tests during October 1968. A vacuum bake-out was performed on the sunshield prior to painting.

As a result of the Program Review (week of 10/20/68) the Qual B SP 1 hardware was not used during the remainder of the program. All work on SP 1 conversion of Qual SA to Qual B was stopped.

Prototype B/Qual B (Qualification SB Program)

The Prototype B Program was redirected to effect conversion to a Qualification B Program, using a combination of prototype and qualification model hardware. The approach in the Qualification B Program was to qualify the differences between the Array A and Array B hardware. A detailed description of the hardware used in the Qualification B Program is given in the "Qualification Test Plan, Array B," ALSEP-TM-321.

The power dissipation test was completed on 22 October. All parameter calibrations were identical to or very close to Array A data and the power dissipation of the Array B Central Station varied between 18.5 and 24 watts over load conditions.

The HFE reintegration test on 6 November verified that the fixes incorporated at subcontractor brought rise and fall times of the timing and command signals within acceptable values.

The Baseline IST was performed in two sections; the first performing all tests possible without HFE (10/24 and 10/25) and the second with HFE (11/8 through 11/12). The IST was completed satisfactorily without hardware faults.

The Array B QTRR was held at BxA on 4 and 5 November and concurrence was obtained to continue tests. Chits were generated on 16 separate topics.

The SP#1 was stowed for vibration during the 14 to 18 November time period. The X and Y axis design limit sine and random vibration tests were successfully completed on 21 and 22 November without any significant indications of hardware fault. A problem with flat conductor cable unreeling from the HFE and CCGE was encountered during Z-axis sine in the 50 to 70 Hz region. The problem was corrected by inserting rubber pads in the reels where cable exits and sine test was completed successfully.

The build-up of SP#2 into stowed configuration for vibration tests was not due to interface incompatibilities between the drill carrier subpallet and the SP#2 pallet. Design changes were incorporated in the subpallet assembly and second build-up was in progress at the end of this report period.

The Design Limit Vibration tests on SP#1 were completed on 26 November 1968. The only problem encountered during the tests was the unreeling of the flat conductor cable from HFE and CCGE cable reels during Z-axis sine. The problem was resolved by insertion of foam pads where the cable exits the reel to increase the drag and prevent the cable unreeling. All Boydbolts released satisfactorily during the Boydbolt Verification Test performed on completion of the vibration test.

The SP#2 Design Limit Vibration tests were completed without encountering any significant vibration problems. Considerable delay in the start of the test occurred due to failure of the LSD to meet its interface. The qual model drill was about 0.2 in. short and would have created an excessive moment on rear mounting pins on drill subpallet. Also, the battery box cover bound against the subpallet. Fit checks were performed on all three flight LSD's and it was determined that SN 1003 was the best fit with respect to length. SN 1003 was redesignated as the qual model and the pin material was changed to increase strength. The battery case interference problem was eliminated by reducing the thickness of shim material between the battery case and battery and raising battery sufficient to clear the subpallet. The drill interface problem was corrected on Flight 3 by BxA rebuilding the interface to fit the SN-1001 and SN 1002 ISD's.

The Qual SB thermal vacuum Open Door test started on 5 December, the Lunar Day IST started 10 December, the Lunar Night IST on 12 December, and the Post Test Open Door IST was completed on 17 December. The overall performance of the Qual SB system during thermal vacuum tests was highly successful.

The CCGE operated functionally and thermally without fault throughout the thermal vacuum test. The only problem encountered was observation of paint peeling and cracks in the fiberglass case.

The HFE functional operation was excellent over the entire test. The only problem was that HFE night time electronic temperatures were 7°C lower than anticipated, possibly resulting in a slight degradation in the accuracy of the science data. The thermal design of HFE was investigated to determine the cause of this low temperature condition.

The CPLEE experiment encountered two faults. The first was that the experiment's switchable high voltage power supply did not operate due to an error in the wiring of the High Voltage Enable Plug. As a result the deflection plate voltages remained at ground potential throughout the test. This switchable power supply has operated successfully during several vacuum PIA's. The second fault was intermittent response of six of the CPLEE science channels to test oscillator counts. This was apparently a temperature dependent problem. All other electronic functions of CPLEE performed without fault throughout the test. Also, the thermal performance of CPLEE was better than anticipated. BxA developed a plan to complete induced environment tests on CPLEE along with the rest of Qual SB, troubleshoot test oscillator problem, and then demonstrate qualification performance of the CPLEE by subsystem level ambient and thermal vacuum tests.

The PSE was not qualified during this test. However, a "tucked skirt" thermal control test and gnomon thermal vacuum qualification were performed on the experiment. The "tucked skirt" test was successful in that it demonstrated that the thermal variations of the PSE could be reduced to ± 3 degrees over the \pm degrees experienced on previous tests with the "flare skirt" configuration. No signs of degradation of the paint or other surfaces on the gnomon or thermal shroud were observed as a result of the test. The electrical performance of the PSE was satisfactory over all test conditions.

The Qual SB Central Station, which was not being qualified, operated without fault throughout the test.

The system level Qual SB tests were completed on 13 January 1969, about 45 days ahead of the schedule presented in the Qual SB Test Plan at QTRR. The schedule improvement was accomplished primarily through better utilization of test personnel than anticipated, so that major tests on two or more models were accomplished simultaneously.

The following tests were successfully completed:

- SP #2 Shock
- SP #1 Shock
- SP #1 Modified IST
- SP #1 Acceleration
- SP #2 Acceleration
- SP #1 Mass Properties
- SP #1 Boydbolt Verification
- SP #2 Boydbolt Verification
- SP #1 Deployed IST
- Post-Acceleration PIA - CPLEE

The Qual SB QAR was held at BxA on 28-29 January 1969. The review was successful and few action items resulted. The majority of post-QAR activity was in the final qualification of CPLEE, and closing out the remaining DR's.

Thermal/vacuum retesting of the Qual SB CPLEE S/N 2 model was accomplished 27-31 March 1969. One additional ambient temperature vacuum PIA was performed on 18 April, after which the ETS was shipped to Rice University in support of the tests on the S/N 3 CPLEE underway there. At a Delta QAR on CPLEE, tentatively scheduled for the week of 28 April, every effort was made to close all DR's and FR's against the Qual SB CPLEE thereby closing the two CPLEE open items resulting from the Qual SB QAR.

The QAR open item against the ALSD interface and redesign was closed by CCO-108 on 22 April 1969.

A Delta QAR was held on 30 April and 1 May 1969. At these meetings, justification and documentation were provided by BxA and BRLD personnel with which to close all open DR's and FR's against CPLEE, with the exception of DR AB 4995 (FAR 245) and DR AB 4996 (FAR 246). These FAR's were sent to MSC for their approval.

MSC approval of FAR's 245 and 246 against Qual SB CPLEE allowed closure of the last remaining chit from QAR (CCO 131).

The Final Test Report on CPLEE Thermal/Vacuum Retest (ATR-207) was released on 26 May 1969. Qual SB was closed.

4.2.3.3 ARRAY B FLIGHT 3

PIA tests were successfully completed during September and October 1968 on the following Central Station components:

<u>Component</u>	<u>Serial No.</u>
Command Decoder (2330509)	S/N-6
Digital Data Processor (2330521)	S/N-8
Analog Multiplexer/Converter (2330524)	S/N-13
Power Conditioning Unit (2330000-3)	S/N-6
Power Distribution Unit (2330450-2)	S/N-8
Diplexer Switch (2330526)	S/N-10
Diplexer Filter (2330525)	S/N-10
Timer (2330626)	S/N-E 50521
Transmitter (2330527)	S/N-17, S/N-18
Receiver (2330523)	S/N-9
Antenna Cable Assembly (2334522)	S/N-10
Central Station Harness (2334794-1)	S/N-9

The Dust Detector S/N-7, Antenna Aiming Mechanism S/N-8, Helical Antenna S/N-9 and the Power Dissipation Module were complete and in Bonded Stores.

Flight 3 component PIA's were completed on 10/8/68 and Central Station Integration was started immediately following harness installation on 10/14/68.

During Central Station integration, two discrepancies were encountered. Thermal Plate temperature sensor 2 read OT. This was corrected by replacing the sensor assembly. A check showed that the thermistor in the assembly measured 47K ohms rather than the nominal value of 15K ohms at room ambient temperature. A failure analysis was initiated to determine the cause of failure. The second discrepancy involved the Analog Data Processor S/N 13 which read OT on HK-3 and HK-6 on the X side of the processor but in tolerance on the Y side. This condition was corrected by replacing Analog Data Processor S/N 13 with S/N 11. A PIA at cold, hot and ambient temperatures was performed on Analog Data Processor S/N 11 in conjunction with the Digital Data Processor S/N 8 prior to installation in the Central Station. Analog Data Processor S/N 13 was returned to the vendor for repair.

During October and November, the following tests were completed in the order in which they are listed:

<u>Test</u>	<u>Procedure No.</u> (233----
C.S. Integration	4386
C.S. Verification	4368
PSE Integration	4388
CCGE Integration	8194
Ant. VSWR Pre. Environ.	8612
C.S. Post Assy Verif.	4369
GA Acceptance (RTG leak & functional)	3057
C.S. Power Dissipation	7929
CPLEE PIA	3067
CPLEE Integration	7948
CPLEE Mass Prop.	4364

The PSE and CCGE were integrated with the Central Station in the open configuration. Following these tests, the Central Station was assembled to the Subpackage #1 deployed configuration. This was done prior to integrating the CPLEE and HFE because these experiments were not immediately available for integration. The remaining applicable tests were performed with the Subpackage deployed.

The antenna VSWR pre-environmental and Central Station Power Dissipation tests were acceptance type tests which were scheduled to be performed following the FTRR. Because of the nature of these tests, availability of test personnel and test facility schedule, MSC approved performing these tests prior to the FTRR. The successful completion of these tests satisfied the requirement for performing these two acceptance tests.

The Flight 3 FTRR was held on 21 and 22 November. Results of the FTRR established that acceptance testing of Flight 3 could proceed.

During November and December, the following tests were completed in the order in which they are listed:

<u>Test</u>	<u>Procedure No.</u> (233----)
HFE PIA	3069
HFE Integration	8195
IST with IPU	4375
System EMI	3088
CPLEE Vac PIA	3067
(following rivet rework per DR 2137)	
SP #1 Mass Props	7907
SP #1 Vibration	8627

The first four tests were performed with SP #1 in the completely assembled deployed configuration.

Stowage of SP #2 was delayed because the ALSD did not comply with its ICD dimensional requirements. This necessitated a design modification with subsequent rework of the ALSD carrier. Schedule impact was minimized by rescheduling to perform dynamic tests on SP #1 prior to performing them on SP #2 as originally planned. Deletion of Timer replacement prior to dynamic tests permitted the revision. Stowage of SP #2 is now complete.

Replacement of the Central Station Timer had been planned to be accomplished immediately following System EMI. This did not occur because a final resolution of the "Timer Problem" had not been achieved. Timer replacement was scheduled to be accomplished following completion of the Flight 3 acceptance test program.

The ALSD Battery was activated by Martin personnel in preparation for SP #2 dynamic tests. Delivery to Martin of the drill with the activated battery following SP #2 tests was deleted by MSC direction.

During December and January, the following tests were completed:

<u>Test</u>	<u>Procedure No.</u> (233----)
SP #1 Tumble	8192
SP #1 Post Dynamic Boydbolt Verification	8639
SP #2 Mass Properties	7908
CPLEE Post Dynamic Boydbolt Verification	3067
SP #2 Vibration	8628
SP #2 Tumble	8192
SP #2 Post Dynamic Boydbolt Verification	8639
RTG Post Vibration Leak & Functional	8631 & 3059
Thermal Vacuum-System	4387 & 7912
Open Door	
Lunar Morning	
Lunar Noon	
Lunar Night	
Pallet #2 Thermal Acceptance	8616

Before starting the System Thermal Vacuum Test, a modification was made to the HFE to increase its heater power during operate mode. This change was made based on Qual SB test results. Following modification, an abbreviated HFE PIA was performed to provide reasonable assurance that no damage occurred as a result of the rework.

Beta Sources were added to the CPLEE, and the PSE pressure was reduced before installing the experiments in the chamber for the System Thermal Vacuum Test.

Subpack #2 Mass Properties, vibration and tumble tests were performed using the ALHT Mass Simulator as directed by MSC at the Flight 3 FTRR.

As a result of repeated fit checks with the ALSD, Subpack #2 pallet was severely soiled and scratched. The pallet was returned to the paint vendor for repair/touch-up, and the Pallet #2 Thermal Acceptance Test was repeated upon its return.

Following Subpack #2 induced environment tests, the ALSD activated battery was removed and an unactivated battery installed by Martin personnel.

During January and early February, the following tests were successfully completed:

<u>Test</u>	<u>Procedure No.</u>
	(233 ----
Open Door T/V IST	4387
Antenna Post Envir, VSWR	8612
HFE Mass Properties	4365
PSE Sensor Mass Properties	4362
Ant. Aiming Mech. Post Envir.	8622
PSE Sensor Mech. Insp. Post T/V	8803
PSE Gnomon Calibration	8644

It had been planned to complete all Fit Checks to procedure 2338638 prior to CARR. This was accomplished except for eight Boydbolts, four of which are associated with the PSE and the other four with the HFE.

Flight 3 CARR was held on 6 and 7 February and the DD 250 was signed on 10 February 1969, five days ahead of the contract delivery date.

In conformance with direction provided at the CARR board meeting on 7 February 1969, a plan and schedule has been developed to accomplish the required activities associated with Flight 3. This plan included HFE tape cable replacement, initiation of an expanded HFE PIA, CPLEE ground strap modification, CPLEE calibration at Rice Univ., initiation of PSE sensor re-work, boom attachment Lanyard modification, ALHT fit checks and ALHT Lanyard addition. The plan included timer replacement in April as well as two alternate plans for replacing the multiplexer. Antenna radiated power test and stowed IST were scheduled to be performed just prior to delivery.

The HFE SN/5 tape cable, damaged during HFE testing in the Thermal Vacuum Simulator, was replaced and the experiment reworked to print.

In preparation for the extended HFE PIA, requested at the CARR by Chit 10.4-1, procedure revisions and modifications of the associated data reduction program were initiated.

CPLEE SN/3 was returned to BRLD for incorporation of a grounding modification. Upon opening the unit, it was noted that one of the printed circuit boards had partially delaminated at the board's mounting points. Re-work was accomplished. A Vacuum PIA was performed and the unit delivered to Rice University for calibration.

PSE Sensor SN/6 re-work was initiated with functional testing.

In accordance with direction received from MSC, an electrical leakage resistance test was performed on the Model 21 RTG. Following this test, the RTG was shipped to GE MSVD for a Fuel Fit Check.

Significant accomplishments during April were:

1. The HFE S/N-5 extended PIA was successfully completed on schedule. Reduction of test data was initiated.
2. A Vacuum PIA was performed on CPI-EE S/N-5 and the experiment shipped to Rice University for calibration.
3. Rework of PSE Sensor S/N-6 was completed.
4. The scheduled Timer design improvement retrofit was completed at Bulova. Upon return to BxA, the Timer successfully passed the Timer functional test which included a vacuum soak at temperature.

During the latter part of April, functional problems were encountered with EASEP. In the process of troubleshooting and rework of EASEP, the following items were removed from Flight 3:

PDU	S/N-8
Receiver	S/N-10
Diplexer Filter	S/N-10
Diplexer Switch	S/N-10
RF Component Interconnecting Coax Cables	

A plan to replace these items was developed. Implementation was contingent on the availability of the Component RF Test Set which was being used to fault isolate the failed Transmitters which were removed from EASEP.

The KSC ALSD Walkthrough to check-out the handling and loading of the drill on the pad was successfully completed on 4-21-69. The walkthrough proved that (1) no additional GSE for handling the drill is required; (2) Subpackage #2 need not be withdrawn from the LM SEQ to load or unload the drill (3) the procedure to load the drill was verified.

Replacement of the components removed from Flight 3 for use in EASEP was accomplished. The replaced Components are as follows:

<u>Component</u>	<u>S/N</u>	<u>History Just Prior to Installation</u>
PDU	7	Removed from EASEP. Hot and cold PIA performed.
Receiver	7	Formerly in Flight #2 and subjected to an over-voltage. Vacuum hot and cold PIA performed.
Diplexer Filter	7	Flight spare. Ambient PIA performed.
Diplexer Switch	10	Originally in Flight #3. Was removed and installed in EASEP for 1st T/V re-run after which it was removed. Ambient PIA performed.
Transmitters to Diplexer Switch Co-ax Cables	-	Original Flight #3 cables. Tested with diplexer/transmitter PIA.
Diplexer Switch to Filter and Receiver to Filter Co-ax Cables	-	Flight spares. Tested in conjunction with component PIA's.

Following test and installation of the replacement components and the originally scheduled replacement timer, a Central Station Verification Test was performed. During this test, the 12-hour timer pulse could not be observed. The malfunction was caused by an open circuit in the Command Decoder Mother Board. The Command Decoder was removed from the Central Station, repaired, and a hot and cold PIA performed to confirm satisfactory Command Decoder operation. After re-installation in the Central Station, a Central Station Verification Test was performed to verify satisfactory system performance.

As scheduled, SP #1 was assembled to the sunshield stowed configuration and a Central Station Post Assembly Verification Test was performed to verify SP #1 functional integrity. Immediately following this test, the reworked Flight 3 PSE Sensor S/N-6 was integrated by performing the PSE section of the IST. During performance of these tests, a malfunction of housekeeping channel 25 was noted. The malfunction was fault isolated to the C/S analog multiplexer S/N-11. This necessitated disassembly of SP #1 to remove the multiplexer for test as a component to confirm that the malfunction was caused by a failure in the multiplexer. The multiplexer S/N-11 was returned to Dynatronics for correction of the failure.

During the time SP #1 was open, the transmitters were removed for the purpose of inspecting them for cracked module cover solder seams. Small cracks were found and the cracked seams were re-soldered. Prior to re-installation of the transmitters, an abbreviated functional test was performed on each transmitter.

Just prior to the return of the repaired and retested S/N-11 multiplexer, a decision was made to replace S/N-11 multiplexer with multiplexer S/N-12 which employed higher reliability FET's and transistors. This decision necessitated a delay in re-assembly of SP #1 because of the tests which had to be performed on S/N-12 before it could be installed in Flight 3. These tests were Sine and Random vibration, acceptance functional tests, ambient PIA and hot and cold PIA in vacuum. Following successful completion of this series of tests, multiplexer S/N-12 was installed in Flight 3 and the SP #1 assembled to the sunshield stowed configuration.

Immediately following re-stow of SP #1, it was noted that the Dust Detector Tape Cable had sustained injury in the form of a surface depression. The cable was replaced, after which a PIA test was performed in the Dust Detector to verify its performance.

SP #2 stowage was completed following receipt of the ALHT and a mass properties test was performed on the subpackage. Following this test, the ALS D S/N-2 was removed from the subpack and returned to Martin for retrofit.

A post assembly verification test was performed immediately following re-assembly of Subpackage #1 which had been opened for the purpose of analog multiplexer re-work. This test was performed with the sunshield stowed and experiments mounted but not connected. Following this test, the experiments were connected and the Radiated Power and MIST Tests were successfully completed. Boydbolt cup caps were installed, the subpackage weighed, a final inspection was performed and the Subpackage #1 was installed in its shipping container on 3 July.

Subpackage #2 was also installed in its shipping container on 3 July.

On 3 July, MSC directed BxA to delay shipment of Flight 3 for the purpose of replacing CPLEE S/N-3 with the Flight Spare S/N-6. This was contingent on successful completion of the CPLEE S/N-6 acceptance tests which were initiated on 1 July. The acceptance tests included vibration, vacuum and thermal tests. They were completed on 11 July.

A pre-shipment status review meeting was held at BxA with MSC on 9 July.

Subpackage #1 was removed from its shipping container on 10 July at which time the CPLEE S/N-3 was removed.

CPLEE S/N-6 was integrated with the Central Station by performing an EIT. To perform this test the antenna was un-stowed and placed in the antenna test hat without electrically disconnecting the antenna. Following this test, the CPLEE was stowed and a System MIST performed. This was followed by a mass properties test. Final inspection and re-installation of Subpackage #1 in the shipping container was completed on 18 July.

On 18 July MSC directed that the ALHT be removed from Subpackage #2 and returned to MSC for modification. This necessitated removal from and re-installation of the subpackage in its shipping container. The work was completed on 21 July.

Flight 3 was delivered to KSC on 23 July. KSC receiving inspection of Subpackage #2 on 25 July. Flight 3 was shipped short the ALHT and ALSD.

The Flight 3 fuel cask assembly arrived at KSC on 8 July, and Receiving Inspection was completed on 9 July. The cask assembly was fit checked to LM-7 on 10 July.

During the LM-7 C²F² exercise the MSC ALSEP training models were successfully fit-checked.

The procedure for the Flight 3 CF² (astronaut deployment and restowage) was completed ready for review by the crew of Apollo 13.

The Flight 3 Test and Checkout Plan (TCOP) was completed in August, and submitted for approval to KSC and MSC.

The connector modification of the cask assembly was completed.

An evaluation of the space and clearance available on the SLA 525 level for ALSEP installation through the proposed new SLA cutout was made at the request of the NASA KSC ALSEP Project Engineer. The evaluation was made using the ALSEP F2 Subpackage 2 and the IM M-3 SLA (mockup) to simulate on-the-pad loading of ALSEP. A series of measurements was made inside the SLA to determine available space for GSE and subpackage loading. Final results of the evaluation indicate that Subpackage 1 could be installed based on the proposed enlarged "cookie cutter" using existing GSE. However, Subpackage 2 could only be installed by performing extensive maneuvering indicating a need for new GSE and modification of the SLA 525 platform.

The PSE Level modification was completed in September.

The Flight 3 Deployment (CF²) procedure was reviewed by the Apollo 13 crew, revised, and subsequently approved by KSC.

The Apollo Lunar Surface Drill for ALSEP Flight 3 was received at KSC from Martin-Denver on 6 October. BxA Receiving Inspection was satisfactorily completed. In addition, the two Battery Charge Units and two Pressure Check Units (ALSD GSE) were shipped to KSC from BxA as directed by NASA.

The ALSEP Flight 3 Deployment (CF²) by Astronauts Lovell and Haise was conducted on 10 October at KSC. During the CF² minor modifications to the HFE ALSD drill were directed by NASA necessitating returning the drill to Martin-Denver. In addition, problems were also encountered with the RTG Shorting Plug and Spectral Reflector. Both parts were subsequently removed and replaced with Flight Article BxA Spares.

Because of decreasing pressure readings, a non-scheduled Flight 3 PSE leak detection test was conducted on 16 October at KSC. The result of the test verified that the PSE was leaking and required immediate sealing. During the repair operation all PSE pressure was lost. Subsequently, the PSE pressure transducer was recalibrated, and the Flight 3 PSE was pressurized and sealed at 350 psi on 19 October. A leak detection test was subsequently conducted to verify the integrity of the PSE. After completing the above and all KSC documentation requirements, the PSE was confirmed as "acceptable for flight" on 21 October.

The Flight 3 Pip Pin Modification was satisfactorily completed.

The Flight 3 SIT (MSFN) test was successfully completed on 30 October at KSC; all paper work was closed out and accepted by NASA/KSC on 31 October.

Flight 3 CCGE was modified by adding a velcro fastening strip to prevent the cable from interfering with a Boydbolt.

The Flight 3 Apollo Lunar Surface Drill (ALSD) was received at KSC from Martin-Denver on 12 November; receiving inspection of the ALSD was completed on 13 November. The ALSD Flight Spare was received at KSC on 17 November.

The Flight 3 Cask Tilt Demonstration and ALSD Deployment at KSC by Astronaut Haise was satisfactorily completed on 18 November.

The Flight 3 Subpackage 1 and Subpackage 2 were installed in LN-7 in December 1969.

The ALSD Battery and Battery Filler kits were received from Martin on 14 January 1970.

An ALSD spare battery was activated and the battery electrical check was satisfactorily performed.

The two Pressure Units (GSE) and Battery Charge Units (GSE) were satisfactorily checked out validating the procedures to accomplish these operations.

Part number decals were affixed to two ALSD wrenches when the Flight and Flight Spare ALSD Power Heads were pressure checked.

Apollo 13 pre-launch pad activities implementing the CCIG shorting cap check, barbell removal, PSE caging pressure check, and ALHT removal were satisfactorily completed.

Fit check of the Flight Spare ALSD revealed an unsatisfactory fit at the BxA/Martin interface points which was subsequently satisfactorily resolved by enlarging drill emplacement/interface holes. During this fit check it was noted that the Fuel Transfer Tool and Dome Removal Tool came loose from their support. This necessitated removing the Structure Carrier Assembly from the launch pad to the

Hyper 2 facility for problem investigation. To provide added assurance that this situation would not re-occur, BxA Initiated a hardware design change.

Flight 3 and Flight Spare GLFC's arrived at KSC on 2 February after being re-worked by General Electric.

A BxA Flight 3 ALSEP hardware configuration review was completed at KSC on January 29 and 30 in preparation for the Apollo 13 Flight Readiness Review.

Flight 3 and Flight spare graphite casks arrived at KSC on 2 February; receiving inspection was satisfactorily completed on 3 February. Assembly of the Flight 3 and Flight spare ALSEP Cask Assemblies were completed on 25 and 26 February respectively.

Modification of the Flight 3 Apollo Lunar Handling Tools (ALHT) was completed on 10 February.

Modification of the Structure Carrier Assembly was satisfactorily completed on 12 February.

Fit check of the Structure Carrier Assembly and ALHT with the E-2B Subpackage 2 Trainer was satisfactorily completed at KSC on 13 February. Astronauts Haize and Lovell were present during the fit check and engaged the carry bar for familiarization with the new spring clip within the bar.

Assembly of the Flight 3 and Flight spare Apollo Lunar Surface Drill (ALSD) was satisfactorily completed on 3 February after a walkthrough at KSC.

The Flight spare ALSD was satisfactorily fit checked to the E-2B Subpackage 2 Trainer pallet.

A successful Flight 3 PSE pressure check was performed on 18 February. In addition, the PSE was vented and the lock-out connector was removed completing the final PSE pad requirements.

The Subpallet Tool Carrier and Apollo Lunar Handling Tools were installed on Flight 3 (Subpackage 2) on 18 February.

All Flight 3 astronaut decals were satisfactorily installed.

Leg modification (CRD 57832) of the Charged Particle Lunar Environment Experiment to provide additional stability in soft soil was satisfactorily incorporated on 18 February.

Fuel Transfer Tool, Dome Removal Tool, Universal Handling Tool, and Carry Bar were installed on the Subpallet Tool Carrier on 19 February.

Flight 3 Timer was started at 5:25 PM Eastern Standard time on 18 February.

The Trainer ALSEP Cask Assembly was installed to LM-7 on 26 February for compatibility verification with the SLA thermal curtains in the IBM Instrumentation Unit.

Investigation of the titanium-inconel weld failure which occurred at KSC on 12 February was completed. The failure analysis report concludes that the cask bands had not been degraded to the extent as to preclude flight worthiness as a result of the spot welding on the Inconel X-750 straps to the titanium bands.

The feeler gage (GSE) for the Flight Spare ALSEP Cask Assembly (ACA) was received at KSC on 2 March and utilized during a cask assembly fit check at the launch pad on 4 March.

The ALSEP 3 and Flight Spare ACA's were satisfactorily fit checked to the FCA on 4 March at KSC.

Flight 3 and Flight Spare ACA's were made ready for installation on LM-7 with the incorporation of four CRD's, namely, 57937, 57938, 57945, and 57946. These CRD's were initiated resulting from the failure analysis of the titanium inconel weld anomaly and consisted of applying gage coat and adding spot welds.

The Flight 3 ACA was satisfactorily installed on LM-7 on 16 March, and the launch pad baroswitch check was satisfactorily completed on 18 March.

The dummy FCA was satisfactorily installed in the Apollo 13 ACA on 24 March, and the alignment of the ACA cooling nozzle was verified on the pad. The installation of the FCA was accomplished by BxA/Sandia, and the nozzle alignment was verified by BxA/IBM personnel. The dummy FCA was removed on 27 March after completing the Count Down Demonstration Test (CDDT).

To comply with KSC requirements, the ALSD ground support equipment (GFE) was modified at KSC by installing pressure gages as replacements for mercury manometers. The purpose was to eliminate any possibility of flight hardware contamination by mercury.

Checkout of the ALSD Pressurization Unit (GSE) was satisfactorily accomplished on 13 March at KSC.

The ALSD Preparation for Flight procedure was finalized on 30 March. This procedure combined operations previously included in three procedures. The ALSD Battery Activation activities were completed on 1 April; the activation, drill reassembly, and functional tests were performed by BxA/Martin personnel. During this operation it was necessary to replace all battery cell relief valves since the valves did not "crack" or reseal at specified values.

The Passive Seismic Thermal Shroud modification was hand carried to KSC on 13 March, the Shroud was satisfactorily installed on ALSEP 3 on 14 March, and operational close-out was satisfactorily completed on 16 March.

A modified Passive Seismic Shroud was installed on the ALSEP 3 trainer and successfully deployed by the Apollo 13 prime crew at KSC.

The trainer ACA was removed from LM-7 following satisfactory completion of the flow test conducted by IBM to prepare calibration curves for the launch pad cask cooling.

BxA/Sandia personnel at KSC installed the "Hot" Fuel Capsule in Apollo 13 on 10 April.

After installation of the "Hot" Fuel Capsule, continuous monitoring and recording of the cask cooling data until Apollo 13 launch, was accomplished. The cask cooling system functioned satisfactorily and the cask temperature remained under 160°F throughout the Apollo 13 countdown as predicted and as is consistent with data recorded for Apollo 12.

A problem on the ALSEP Cask Assembly (ACA) was detected on 8 April at the launch pad during the Apollo 13 countdown. Two shear wires on the ACA had been cut and one bolt was missing and one bolt loose on the Cask Retainer Assembly. The problem was resolved expeditiously and ALSEP 3 was cleared for flight without delaying the countdown by replacing the shear wires, replacing the missing bolt, and tightening the loose bolts. In addition both bolts were lock wired. To preclude a "repeat" of this problem BxA initiated a proposal for an "installed cask" protective cover.

Apollo 13 was launched on 11 April 1970 and the ALSEP Array B Flight 3 System was lost when the mission was aborted.

4.2.4 ARRAY C

4.2.4.1 PROTOTYPE C

The prototype C model utilized the prototype A 2330399 assembly (thermal plate plus Central Station electronics), which was re-worked to the Flight 4 configuration.

During March 1968, all Central Station components were subjected to low and high voltage performance tests. All tests were completed satisfactorily except for the data processor component. A suspected integrated circuit failure was encountered and the data processor was returned to manufacturing for rework.

PIA's were completed on the Active Seismic Experiment Mortar Box and Geophones. The GLA test was started and stopped pending procedure revision.

The Central Station Integration procedure (2333041) was released in April, Data Subsystem test sets were modified, and Integration was started.

The Proto C Central Station Integration was completed per Procedure 2333041. STS 1 buy-off was completed. Proto C was configured for experiment integration; and a "walk through" of the procedure was completed without applying power to the Central Station. The necessary computer program was completed and checked out.

The ASE mortar box, geophone-thumper assembly and Central Station electronics were tested through the integration PIA (Procedure 2333025). The subsystem had only one outstanding DR resulting from the PIA. The testing of the EED's was discussed with MSC and test procedures were forwarded to MSC for comment.

The CPLEE was returned from RICE. A PIA was conducted, the experiment vibrated to acceptance levels, and the PIA repeated successfully.

The Prototype C Experiment Integration was completed in June 1968, and included the following tests:

- Central Station Turn-On (2334344)
- using Experiment Simulator
- Integration of PSE
- Integration of SIDE
- Integration of CPLEE.

The SIDE and PSE were integrated with no appreciable problem. The short period sensor data amplitude was low; however, it was dispositioned to continue prototype testing. During CPLEE integration, a failure occurred in Data Multiplexer S/N 5. The unit was replaced with S/N 6 and the defective unit returned to Dynatronics for repair. Following replacement of the multiplexer, the only problems encountered were software interface problems. This was understandable since the experiment was being integrated for the first time.

Following the ASE Integration, the primary structure and thermal bag were mounted to the thermal plate. The system was then configured in the screen room for IST, Crosstalk, and ASE-EMI testing.

The Prototype C system testing was completed in July with the performance of the following tests:

- . ASE Integration
- . Integrated System Test
- . Crosstalk Test
- . ASE-EMI Test.

During the ASE EMI test a failure occurred in the data multiplexer SN 6. The failure was attributed to a negative input transient. The input circuitry was modified by adding diodes to prevent recurrence of such transients. The only other

problems involved debugging the software and test procedures which were being used for the first time.

Upon completion of Proto C system testing, a subsystem EMI test was completed successfully on CPLEE.

4.2.4.2 QUALIFICATION C

The thermal vacuum configuration of the Qual C Central Station was completed in November 1968 and was used with the ASE DVT model in the Qual SB/ASE DVT thermal vacuum tests.

The ASE models were resequenced so that the Qual ASE would be available for thermal vacuum testing with Flight 3.

The Qual C QTRR was held on 12 and 13 December 1968 at BxA. The Qual C Test Plan (TM-342) and a list of items being qualified under the Qual C program was reviewed and approved. Five requests for change were generated and all the approved requests were incorporated in the program.

The Inert GLA Resistance Check was made on 3 January 1969, and the ASE Subsystem PIA conducted 9-11 January 1969. The first of the three scheduled Astronaut Switch Assembly tests (TP 2338643) was accomplished successfully on 9 January 1969.

Delivery of the Qual C ASE delayed the start of the Flight #3 thermal/vacuum test by about three days. The open door functional test on ASE was conducted on 15 January and the door was closed and pumping started the morning of 16 January 1969. A brief return to ambient conditions was required to repair an inoperative mechanical linkage to the Thumper, and pumping resumed the morning of 17 January 1969. Once underway, the T/V test proceeded smoothly and was completed well ahead of schedule. At lunar night, on 22 January 1969, the ASE exhibited a failure due to a grounding fault which existed in the GSE external to the T/V chamber. Subsequent to this failure, it was impossible to turn on the ASE. At the completion of the T/V test, the ASE Central Station electronics was removed from the chamber and troubleshooting started. It was determined that three flat-packs had been made inoperative by the grounding fault.

The second of the scheduled three Qual C Astronaut Switch Assembly tests was conducted on 31 January 1969.

During the period of GSE rework after the inoperative Qual C ASE was removed from the T/V chamber, a test plan to constitute the completion of T/V testing was developed. This plan called for the use of two Conrad chambers, and both system and component level tests, in order to verify the qualification of the Qual C ASE.

The T/V testing of the Qual C ASE was satisfactorily completed in Conrad chamber tests, conducted from 25 February to 1 March 1969.

After completion of troubleshooting of the GLA, Mortar Box and CSE after Conrad chamber tests, a logbook review was accomplished on the ASE to allow the start of the ASE subsystem PIA. This logbook review was extensive and detailed, since many mechanical rework items resulting from CRD's and DR's were left unaccomplished so that the electrical PIA test could be undertaken. The ASE PIA was performed 2-8 April 1969, with the vast majority of encountered problems attributable to the GSE.

Because of the numerous outstanding rework items listed as open against the Qual C ASE, it was decided to deliver the ASE to Manufacturing to accomplish these tasks, rather than carry them as open through the ASE EMI test. This mechanical rework was undertaken 10-20 April 1969. After a thorough review of the Qual C ASE logbook, toward resumption of tests, it was decided that the new 2333076 EMI procedure might better be verified using the DVT model of ASE.

On 24 April 1969, a Qual C Status Meeting was held. At this meeting, the schedule-to-completion was reviewed, with possible improvement areas noted. DR status was discussed, with the most recent Qual C DR status list from BxA QA indicating about 14 DR's not closed. BxA committed to pushing for full closure of all DR's prior to QAR of Qual C.

While the DVT model ASE was undergoing EMI tests to verify the setup and procedure, the Qual C ASE was scheduled for its Mass Properties test on 29 April. As the test got underway, an interference was discovered between the Mortar Box and the handling fixture (DR AB 5236). After machining the fixture, the Mass Properties test was conducted on 1 May. The S/N 1 Dust Detector, S/N 1 Helical antenna, S/N 1 CPLEE, and EM-3 Mass model PSE were delivered to Manufacturing for build-up of the Qual C Subpackage 1. After completion of build-up, Shock tests were successfully performed on 16 May. Vibration tests were successfully conducted from 19 to 21 May, and Acceleration tests at Mishawaka were successfully conducted on 22 May 1969.

After completion of the induced environments tests, the Boydbolt Verification test was completed on 26 May 1969. This test was followed by:

- Inert GLA Resistance Test (-3023) - 5/28/69
- Astronaut Switch Assy Test (-8643) - 5/29/69
- ASE Subsystem PIA (-3025D) - 5/29-6/3/69
- Weighing of GSE (Completion of Mass Props.) - 6/3/69
- ASE EMI (-3076A) - 6/6-10/69

The QAR of Qual C was convened as scheduled on 11 June 1969. It was pointed out at QAR that the last remaining open item from QTRR had been closed on 5 June 1969 by CCO-130. This chit had called for ASE subsystem qual reports to be provided as part of the total ASE final qual documentation.

There were five open items defined at the Qual C QAR:

1. One chit was written by MSC requesting that BxA "provide rationale to substantiate qualification of Flight 4 hardware not subjected to Qual C mechanical environments, i. e. all except ASE hardware. Differences between Qual SA or Qual SB response vibration and the levels seen in the Flight 4 configuration should be considered. This information should be made part of the summary qualification report."
2. A Qualification C Test Summary Report was requested by MSC.
3. DR AB 4398 was to be rewritten in the area of cause and corrective action to state that damage to the GLA connector was not as a result of testing, but from mishandling, and to add to the KSC handling procedures to avoid a similar problem there.
4. A few WO/OS items and other open items existed in both the -5800 S/P 1 log and in the -0750 ASE log. These items were to be closed either by accomplishing the task or by deleting the requirement.
5. FTR items not yet released (ASE EMI, ASE Mass Properties, Induced Environments and Post Induced Environment Functional) must be completed now that testing of Qual C is over.

All Qual C DR's were closed, and completion of the above items constituted close-out of Qual C.

4.2.4.3 ARRAY C FLIGHT 4

The Central Station component PIA's were completed, Central Station build-up and integration tests were completed, and the experiment integration was begun on 19 December 1968. As of 20 December, the SIDE and CPLEE had been received and the SIDE PIA completed. The PSE PIA was completed on 20 December.

The Flight 2 SP #2 with exception of the SIDE was transferred to Flight 4 thus allowing all SP #2 acceptance tests to be deleted from the schedule.

The SIDE was integrated by 30 December. Integration was interrupted by delays encountered in completing the ASE central electronics. The major source for the delay was failure of the 16-channel multiplexer during manufacturing "in process" testing.

During the delay, CPLEE was returned to Bendix Research Labs for incorporation of CDR 56332 and from there it was taken to Rice for calibration prior to start of acceptance tests. The RTG was returned from GE and fabrication of SP 1 hardware was completed.

During February, the following major tests were completed.

<u>Test</u>	<u>Procedure No.</u>
	233----
ASE CSE PIA	3073
ASE Post Assy PIA	3025
ASE Integration with C/S	8633
PSE Mass Properties	4362
Timer Verification Test	4344

The timer installed in Flight 4 incorporated all of the latest design improvements.

CPLEE S/N-5 was returned from Rice without having completed calibration. Functional testing at Rice indicated that performance of the unit was normal in all respects.

A fit check of SIDE on SP #2 was completed without difficulty.

Rework of the former Flight 2 RTG shorting plug to the Flight 4 configuration was completed.

During March, the following tests were completed:

<u>Test</u>	<u>Procedure No.</u>
PSE Gnomon	2338644
CPLEE Vacuum PIA	2333067
RTG Shorting Plug Functional	2337923
Ant. VSWR - Pre-environmental	2338162
C/S Post Assy. Verification	2334347
PDM Resistance	2337932
C/S Power Dissipation	2337930
Thermal Vacuum	2334367
Open Door	
Lunar Morning	
Lunar Noon	
Lunar Night	

Subpackage #1 was stowed in the extended Sunshield Configuration prior to conducting the thermal vacuum tests.

During the Open Door Thermal Vacuum test, problems were encountered with the SIDE SN-6 and the ASE which delayed closing the chamber door and starting the pump.

The SIDE S/N-6 failed to function and was replaced by SIDE S/N-5 which was hand carried from Rice. Before installing in the chamber, an electrical test was performed on the unit to verify its integrity.

False real time events occurred with the ASE. This was found to be caused by a grounding problem. After correction, the ASE performed properly.

The Thermal Vacuum Test was completed in April. Problems were encountered during the test with the PSE, Timer and a loss of sensitivity in the uplink.

Troubleshooting indicated that the Timer was defective and that the PSE/CSE was the most probable cause of the PSE problem. Loss of uplink sensitivity could not be repeated. However, the receiver was suspected as being the most probable cause of the problem.

The PSE/CSE, Timer and Receiver were replaced with Flight Spare units. By MSC direction, the transmitters were replaced with the Flight Spares so that Flight 4 and EASEP would be on the same frequency.

Following component replacement, verification tests were performed and the Central Station was returned to manufacturing for assembly to the Subpackage #1 configuration.

Just prior to Subpackage #1 assembly, the EASEP encountered difficulties with its transmitters. To correct the problem, the Flight 4 transmitters, Diplexer Switch and interconnecting Coax Cables were removed from Flight 4 and installed in EASEP. A recovery plan for replacement of the components was generated.

Replacement and test of these components in the Flight 4 System was accomplished in May and system performance confirmed by performing a Central Station Verification Test.

The transmitters which were installed in Flight 4 were the original Flight 4 transmitters. The replacement Diplexer Switch and Coax Cables were flight spares.

After installing the replacement transmitters S/N-16 and 19 in the Central Station, it was noted during system test that the STS receiver could not be locked at the low data rate with transmitter S/N-19. Troubleshooting revealed a cracked seam in one of the S/N-19 transmitter module cases. This was repaired and the transmitter tested both as a component and in the system to confirm satisfactory operation.

Flight 4 SP #1 was assembled to the deployed configuration and a C/S Post-Assembly Verification Test and an IST with the IPU was successfully performed. Flight 4 was then deployed in the EMI chamber and the EMI test was run. During the ASE section of the test, considerable difficulty was experienced with multiple false ASE real time events.

The Flight 4 Dust Detector was retrofitted to the EASEP configuration. A PIA test was performed following retrofit and the unit was re-installed in the system just prior to the C/S Post-Assembly Verification Test.

A "C" Configuration Central Station employing prototype components and the ASE DVT model was assembled for the purpose of EMI troubleshooting and determining the effectiveness of shielding, filtering and evaluation of design modifications.

Flight System #4 was used for EMI troubleshooting measurements until the "C" Configuration Test System became available on 30 June. After that time, all system tests were performed using the re-assembled "C" Configuration Test System.

There were two characteristics which made the design inoperable. These were; (1) extremely wide capture bandwidth of the ASE receiver front end and (2) spurious noise generation within Central Station and ASE components, having frequency components within the receiver bandwidth.

During August, the modifications to eliminate the ASE EMI problems were finalized. These modifications are itemized below:

1. Limit the tracking bandwidth of the ASE Central Electronics Receiver.
2. Add a 30 MHz ± 125 KHz bandpass crystal filter and a 3 db attenuator pad in series with the ASE receiver antenna input coax line.
3. Add low pass ferrite filters in series with 21 selected Mortar Package Assembly and Thumper Cable lines.
4. Shield four Central Station Harness wires. (Split phase modulation data lines (2) from the Data Processor to the Transmitters, ASE data line from ASE Central Electronics to the Data Processor and clock line from the Data Processor to the ASE Central Electronics.)
5. Add an RF choke to each of the eight ASE A-D converter accumulator output lines within the ASE Central Electronics.
6. Modify the ASE receiver detector output circuit and the ASE level detector to provide improved noise immunity.

Because of space limitations within the ASE Central Electronics, the 30 MHz bandpass filter and the 3 db attenuator pad were mounted on the Central Station Thermal Plate. The 21 ferrite filters were mounted, within the Central Station, close to the Mortar Package Assembly and Thumper Tape Cable Connectors.

CPLLEE S/N-5 and SIDE S/N-5 were delivered to Rice University on 30 July for the purpose of re-calibration.

A Flight 4 EMI Status and Plan Meeting was held with MSC at BxA on 27 August 1969. At this meeting, the entire EMI problem was reviewed and the modifications necessary to eliminate the problem were presented. The plan and schedule to implement the changes and to complete the Flight 4 acceptance program through delivery were presented. During the meeting, MSC requested that the plan be modified to change the downlink frequency of Flight 4 from Channel 1 to Channel 4 (2279.5MHz).

The Flight 4 schedule and plan was modified to change the downlink frequency as directed. The plan entailed the use of transmitters S/N-10 and -20 in Flight 4 through System Thermal Vacuum Testing with transmitters S/N-7 and -9 as back-up. Because transmitters S/N-10 and -20 were not available, the back-up transmitters S/N-7 and -9 were installed in Flight 4.

All Central Station EMI modifications were incorporated in the Flight 4 Central Station. A Central Station Verification Test was initiated in September 1969.

EMI modifications were made to the Flight 4 ASE Central Electronics. During the PIA, a malfunction occurred in the 16-channel multiplexer-A/D converter. The malfunctioning unit (S/N-11) was removed from the ASE and returned to the vendor for re-work.

Thermal characterization and PIA of PSE Sensor S/N-3 was completed.

Calibration of CPLEE S/N-5 was terminated at Rice University on 2 September 1969 because of problems encountered with the experiment. The experiment was returned to BRLD for fault isolation, re-work and re-test. The degraded analyzer in CPLEE S/N-3 was replaced, the unit tested and returned to Rice for recalibration.

A Flight 4 Delta FTRR was held at BxA on 20 and 21 October 1969. The major objective of the meeting was to present the status and plan for completing Flight 4. The plan and schedule, "Flight 4 System Integrated Working Schedule", dated 10-16-69, was accepted as presented.

The Central Station Verification Test, was initiated and completed. This test was performed with transmitters S/N-7 and 9. Test results indicated that transmitter S/N-7 was not acceptable and it was therefore removed for fault isolation and re-work. Analyses of the problem lead to the conclusion that re-work of transmitter S/N-7 could not be accomplished within the required time frame. Therefore, all effort was immediately transferred to completion of transmitter S/N-20 re-work and test. This was successfully accomplished and S/N-20 was installed in the "B" transmitter position of the Central Station. Formally, transmitter S/N-9 was installed in this position. During removal of S/N-9 from the "B" transmitter position, it sustained a severe mechanical chock. Subsequent test of this transmitter indicated a malfunction which could not be corrected by retuning. Therefore, transmitter S/N-9 was replaced with S/N-5. Before installing S/N-5 in the Central Station, a hot, cold, and ambient temperature vacuum test was performed on the transmitter.

A PIA was successfully completed on the Flight 4 ASE Central Electronics after replacing the 16 channel multiplexer S/N-11 with S/N-8. The unit was installed in Flight 4 and an ASE Experiment integration test was successfully performed. This test included the flight ASE 30 MHz bandpass crystal filter.

Calibration of CPLEE S/N-3 and SIDE S/N-3 was completed by Rice University and returned to BxA. A PIA was performed on both experiments.

During the early part of November 1969, a Central Station Post-Assembly Verification Test, an IST, and an EMI Test were successfully completed on the Flight 4 System which incorporated all of the EMI design modifications. These tests proved that the EMI problem previously encountered with the ASE during the original EMI test, on Flight hardware which was performed prior to incorporation of the EMI design modifications, had been eliminated.

Following these functional tests, Subpackage #1 was assembled to the stowed configuration and a Mass Properties, Vibration and Tumble Test was performed. A Modified IST was then run as a post-vibration functional test. Performance of the Central Station and all experiments was satisfactory except for a brief period during which the CPLEE required an abnormally long time to "lock-up". The cause of malfunction was traced to the Schjeldahl connector mounted on SP #1 to which the CPLEE tape cable was connected. The problem was a poor contact between two of the pins in the SP #1 side of the connector and the two corresponding printed circuit leads on the CPLEE tape cable side of the connector. Adjustment of the pins eliminated the poor contact problem. Before isolating the problem, trouble shooting indicated that the condition could not be repeated at will and was of an intermittent nature. Eventually, the malfunction failed to recur. CPLEE was subjected to a Thermal Vacuum Test with no indication of malfunction. Extensive testing was also performed on SP #1, with the CPLEE disconnected. This proved that the malfunction was not caused by the Central Station electronics.

A SP #1 Post Dynamic Boydbolt Verification Test and astronaut handling tools check was completed following the Modified IST.

On 6 November 1969, MSC requested that BxA install the off-equator thermal modifications to SP #1 and replace the presently installed ALSEP C/S transmitters S/N-5 and -20 with transmitters S/N-16 and -19 prior to System T/V.

SP #1 was opened to the -399 level after completing the Post Dynamic Boydbolt Verification Test so that the thermal modifications could be added and the transmitters replaced.

The frequency of the Flight 4 transmitters S/N-16 and -19 was changed to Channel 4. Acceptance testing of transmitter S/N-16 was successfully completed. Functional performance difficulties were experienced with transmitter S/N-19 in the transmitter T/V Acceptance Test.

Subpackage #2 was assembled using the Flight 4 ALHT which was received on 30 October. A SP #2 Mass Properties, Boydbolt Verification, and astronaut handling tools fit check tests were performed.

A fit check and deployment test of the thermal modifications was performed as part of the thermal modification installation with satisfactory results.

During the time Subpackage #1 was disassembled for the purpose of installing the thermal modifications, Data Transmitter S/N-20 was removed from the Central Station and replaced with S/N-6. This was done so that the frequency of transmitter S/N-20 could be changed to the Flight 4 frequency.

Following thermal modifications, transmitter replacement and reassembly of Subpackage #1 to the deployed configuration, a Central Station Post Assembly Verification Test was performed prior to deployment of the Flight 4 System in the thermal vacuum chamber.

An intermittent malfunction of CPLEE S/N-3 occurred during the open door portion of the Thermal Vacuum Test. Because of the intermittent nature, infrequent occurrence, and apparent temperature sensitivity of the malfunction and the fact that a flight spare was not readily available, the Thermal Vacuum Test was conducted with this CPLEE. Flight 4 System Thermal Vacuum Test with thermal modifications made to Subpackage #1 was successfully conducted. Subsequent to the System Thermal Vacuum Test, the CPLEE S/N-3 was again tested using the CPLEE test set. The malfunction was repeated and isolated to the CPLEE logic board.

A Post Thermal Vacuum Antenna VSWR and Antenna Aiming Mechanism Test and a PSE Sensor Visual Inspection was completed.

The frequency of transmitter S/N-20 was changed to the Flight 4 frequency.

Transmitter S/N-16, after successfully completing all acceptance tests, was inspected via X-ray. The X-ray indicated possible loss of the bond between a transistor and its mounting surface in one of the modules. The module was opened and the fault verified. Repair was not satisfactory so the module was replaced.

Stowage of Subpackages 1 and 2 was completed on 9 January 1970 in preparation for a formal CF² at BxA on 21 January. The CF², along with the plans for replacing the Bulova Timer, was cancelled on 13 January. Subsequently, SP #1 was disassembled and the PSE CSE was removed from the Central Station for re-work. The re-work consisted of replacing diodes in the sensor caging circuitry for the purpose of improving low temperature performance. Re-work and verification testing was successfully completed. Re-integration of the PSE CSE was initiated and was accomplished by performing the PSE Experiment Integration Test.

CPLEE S/N-3 was returned to BRLD for replacement of its logic board. SIDE S/N-5 was returned to Rice University for re-calibration.

A Post Thermal Vacuum PIA functional verification test was performed on the ASE mortar box, after removing the inert GLA.

Transmitters S/N-19 and -20 successfully completed acceptance testing, which included functional test over temperature and a vibration test, and thermal

vacuum testing. The transmitters were installed in Flight 4, and tests were performed to verify the performance of these transmitters in the system.

Flight 4 Astronaut Cask Tilt operation was satisfactorily completed on 15 January during the LM-8 Descent State C²G².

The Central Station Timer was set for a nominal transmitter turn-off time of four (4) years.

Installation of the LTA in the ASE mortar box was completed along with a functional verification test.

A System Radiated EMI Test was performed following assembly of Subpackage #1 and subsequent to a C/S Post Assembly Verification Test. Results of the EMI Test showed a slight out-of-tolerance condition at 285 MHz. A request for waiver was initiated.

By MSC request, the ALHT S/N-1004 was removed from SP #2 and shipped to MSC for modification. The plan was to deliver SP #2 short the ALHT.

The RTG Mod. 23 was removed from SP #2 for the purpose of performing a leak and resistance test on the RTG. The tests were completed and the RTG was restowed on SP #2/

CPLLEE S/N-5 replaced S/N-3 as the Flight 4 unit. This was necessitated by a failure in the A analyzer noted during functional testing of CPLLEE S/N-3 subsequent to replacement of the logic board in this unit.

Flight 4 graphite cask arrived at KSC from General Electric on 16 February; receiving inspection was satisfactorily completed on 27 February.

A Flight 4 CARR meeting was held at BxA on 9, 10, and 11 March 1970. The Board Meeting associated with this CARR was redesignated a Pre-CARR Board Meeting because delivery of the Flight 4 SIDE S/N-5 to BxA was delayed. The reason for the delay was a longer than anticipated time for SIDE off-latitude modification at Rice University and a tentatively planned four to six week T/V test of the experiment at MSC. For planning purposes, MSC established a tentative delivery date for SIDE S/N-5 to BxA of 15 May 1970.

Subsequent to the CARR meeting, the following tasks, which had not been previously planned, were directed for BxA accomplishment prior to delivery of the Flight 4 system:

1. Perform a T/V test on CPLLEE S/N-5.
2. Modify ASE Geophone cable distance markers for improved contrast (CRD 58573).
3. Add an anchor attachment loop to the ASE Thumper tape cable (CRD 58574).

4. Add an additional alignment slot to the antenna aiming mechanism and a directional reference marking on the mechanism container for the purpose of simplifying off-latitude deployment of the system (CRD 57928).

Off-latitude modification of CPLEE S/N-5 was completed. Functional performance and acceptability of the CPLEE following installation of the modification was verified by performing a vibration test, a post-vibration vacuum functional test, a logic board visual inspection, a post-logic board inspection vacuum functional test and a thermal vacuum functional test.

The pre-ship SP #1 stowed MIST and radiated power tests were successfully completed. CPLEE S/N-5 was integrated with the system during these tests. With the completion of these two tests, all scheduled pre-ship system tests were successfully completed.

NASA/KSC directed that the ALSEP Subpackages be installed on the launch pad rather than in the LM Landing Gear Fixture in the MSOB.

SIDE S/N-5 was received from Rice University on 4/20/70 with the off-latitude modifications installed on the experiment. A connector fit check and a PIA was performed as part of the incoming inspection at BxA. As a scheduled part of the PIA, the dust cover was released exposing the second surfact mirrors. It was noted that one of the mirrors was cracked. During replacement of this mirror on 4/24/70 by Rice personnel, additional discrepancies were noted with respect to the Thermal Spacer Assembly. Subsequently, the entire assembly was replaced on 4/30/70.

Directional reference markings on the antenna aiming mechanism container were completed. The aiming mechanism was installed in the container and the assembly stowed on SP #2.

The Spacecraft LM Adapter (SLA)/GSE Walkthrough (CCP 223) was successfully completed at KSC on 14-16 April. The walkthrough simulated the installation of ALSEP Subpackages 1 and 2 on the launch pad, a requirement for Apollo 14 and subsequent flights, utilizing mock-up GSE and preliminary procedures.

Receiving Inspection of the live Grenade Launch Assembly (GLA) was initiated 25 March and completed on 8 April in the Pan American Storage Area at KSC. Six minor DRs were generated during this operation. A GLA Configuration Review was held on 29 April at KSC. The DRs initiated during the GLA Receiving Inspection activities were reviewed with the BxA GLA Project Engineer.

As directed by NASA the Flight Spare ALSD (Apollo Lunar Surface Drill) was shipped to the Martin Company on 24 April 1970.

The GLA Test Set and Inert GLA arrived at KSC on 21 April for ALSEP-4 Pre-launch preparations. Receiving inspection was completed on 24 April.

Mounting of SIDE S/N-5 on SP #2 was unsuccessful because of an out of tolerance condition of the SIDE interface. This was verified by measurement and fit checks with the interface tools. In addition, a yellow discoloration of the thermal paint on the SIDE case was noted. Subsequently, the experiment was returned to Rice University for the purpose of replacing the discrepant case.

A MIST, modified to include an ASE ring down test, was performed in May 1970 to verify the functional integrity of the ASE Thumper Geophone assembly subsequent to incorporating improved contrast markings on the Geophone cable, the addition of an anchor attachment loop to the Thumper tape cable and the addition of rivets to the Geophone housing.

As directed by MSC, a lanyard was added to the RTG shorting switch to enable reset of the switch by the deploying astronaut.

With the exception of SIDE, all planned efforts associated with Flight 4 were completed. Both subpackages were installed in their shipping containers and pressurized. The log book for SP #1 was closed and the appropriate contents integrated into the system ADP.

The Subpackage 2 subpallet right front pedestal to which the SIDE is attached was modified in accordance with CCP-255 to increase clearance between the pedestal and the case of the SIDE experiment.

SIDE S/N-5 was received at BxA on 4 June and a PIA test was performed on the experiment prior to its final installation in Flight 4.

In accordance with CCP-258, CCGE S/N-4 was electrically integrated with the Flight 4 Subpackage 1 on 10 June to prove functional performance and compatibility between the CCGE and Array C. A PIA Mass Properties test and a Fit Check was also performed on the experiment. Following this series of tests, CCGE S/N-4 was delivered to MSC on 15 June 1970 for a Thermal Vacuum test.

A Delta CARR was held at BxA on 25 June and the DD-250 was signed on 26 June 1970.

The Flight 4 Array C was delivered to KSC on 29 June 1970. Subpackages left Ann Arbor by air at 10:20 AM EST and were delivered to Hyper II at 13:15 PM EDT; receiving inspection was initiated on 1 July. The inspection resulted in seven DR's, six of which were minor, and one on the PSE (S/N-3) pressure check reading which was 1 psi below the specified lower limit.

Engineering personnel made the necessary measurements on Flight 4 and E-2C Trainer at KSC for designing the dust cover modifications. The measurements were made prior to removing SIDE which was returned to Time Zero Corporation for modification.

The Flight 4 CF² was performed 23 September by the prime and backup crews. ASE modifications requested were an anchor loop add-on to the geophone cable, relocation of the "D" ring on the MPA, and an anchor loop add-on to the Thumper power cable.

The modified PSE (S/N-4) and shroud assembly was hand-carried to KSC on 8 September. Receiving inspection of the experiment was performed and it was installed on Flight 4 with no problems on 9 September. The PSE (S/N-3) and shroud assembly removed from Flight 4 was hand-carried to Ann Arbor on 9 September and was available as a flight spare for support of the Flight 4 SIT test scheduled for 11-3-70.

The repaired Flight 4 SIDE experiment was returned to KSC from Rice University on 21 September and the dust cover modification was installed on 22 September. The SIDE was restowed by Rice personnel after the CF² and was ready for installation on the subpackage.

The following Flight 4 modifications were incorporated at KSC during September:

- ASE Bubble Level, CCP 252
- CPLEE Off-Equatorial, CCP 229
- Subpack 1 and SIDE Dust Covers, CCP 271
- SIDE Lanyard, CCP 272
- PSE Stool, CCP 265
- SIDE Cable Connector Striping
- GLA Foam Pads

Calibration of the System Test Set for the Flight 4 SIT was initiated on 9 September and completed on 28 September. Auxilliary GSE required to perform the SIT test was readied and delivered to KSC.

The spare ALSEP Cask Assembly (ACA-S/N-8) was assembled with the light-weight cask on 3 November for the Delta CF on 12 November during which a successful tilt demonstration by the flight crew was performed. The flight ACA-S/N-10 and spare ACA were assembled to flight configuration on 17 and 24 November, subsequent to which dimensions for feeler gage fabrication were determined. Both feeler gages for on-the-pad installation were fabricated and delivered to KSC on 25 November and 1 December.

The Flight 4 dome removal tool was received at KSC on 10 November 1970; fit checks were successfully performed with the DRT and flight and spare ACA assemblies.

As was finalized during the CF², flight crew-approved ALSEP 4 decals were installed on both Supackages on 4 November.

The flight 4 lot ordnance verification tests were performed in the Field Ordnance Test Lab (FOTL) on 5 and 6 November with satisfactory results.

The mortar package assembly (ASE) leg lock modification was resolved on 6 November. The "T-Tape" modification was installed on the E-2C trainer mortar package and was reviewed by RASPO, NASA/KSC, and flight crew personnel demonstrating the deployment sequence. This modification was then installed on Flight 4 for final astronaut confirmation which was obtained during the Delta CF².

Antenna cable deployment problems during the CF² were resolved with installation of new clips and pins on the antenna cable release mechanism on 9 November; the mechanism was installed on the antenna cable and operated several times with satisfactory results. (CRD's 58945 and 58946)

The following modifications were incorporated:

ECN 58973 - Thumper Assembly - Change the amount of transfer adhesive used on the last 150 feet of cable to reduce pull force.

ECN 58974 - Thumper/Geophone Assembly - Change added aluminized nylon tape at four places to prevent the anchor loop from slipping along the cable and added transfer adhesive tape adjacent each geophone to prevent cable "spool-off" when the astronaut slows down and stops to deploy a geophone.

Per crew request available cable outside of SIDE cable reel was increased (ECN 58977)

Geophone No. 1 Thumper power cable accidentally creased during deployment - cable inspected with eyeglass; no damage to cable and/or conductors revealed.

UHT "hard" to insert in No. 22 Boydbolt cap - cleaned Boydbolt and revised procedure to eliminate excessive epoxy used during cap installation.

The SIT test was performed on 23 November and was satisfactory except for a configuration error in the final shut-down of the ALSEP transmitter, and for ASE high bit anomalies. The transmitter was left "off" instead of "on" and the questionable RTE's (real time events) occurred because there was no requirement to remove shorting plug TP-4 for the SIT. After consultation and coordination with MSC, the "transmitter on" portion of the test and the ASE high bit rate portions with the shorting plug removed were repeated and satisfactorily concluded.

Hardware deliveries to KSC in November 1970 to support Flight 4 test and restowage operations were as follows:

1. Dome removal tool
2. Transit container and lifting frame (SLA/GSE)
3. Cask Assemblies (Flight & back-up) feeler gages
4. PSE sensor exciter

5. Specular reflector
6. Pins and springs for Antenna Cable Release Mechanism
7. Scotchtread
8. Thumper Cable Straps (2)
9. Boydbolts (7)

Flight 4 Subpackage 1 was restowed on 3 December 1970 and moved to Building M7-1210 (Hyper II) on 4 December in preparation for "live" GLA loading on 7 December 1970.

Final inspection by the ASE PE on 7 December revealed an oversized counter-bore on the Thumper Impact Plate resulting in a DR. Decision was made to "use as is" after structural analysis revealed that the hardware was satisfactory.

The Flight 4 Mortar Package Assembly bubble level was aligned, drilled, and pinned on 9 December, and the live GLA's were loaded in the Mortar Box on 11 December. Epon bonding of the screw caps was also accomplished on 11 December.

Flight 4 ALSEP Cask Assembly was delivered to KSC, and receiving inspection successfully completed on 2 December 1970.

Subpack 1 GLA and Thumper restowage was performed on 15 and 16 December with completion accomplished at noon on the 16th, and the Flight 4 Timer was started on 16 December at 2:57 PM (EST). Subsequently, Subpack 1 was installed in the SLA transit container.

Subpack 1 was transported to Pad 39A and installed in LM-8 on 16 December. Final SPI pad activities consisting of a PSE pressure check, cutting the PSE vent tube, and removing the PSE lock-out connector were subsequently satisfactorily completed. Close-out photographs were taken of Subpackages 1 and 2 in the SEQ Bay after all work was completed.

Astronaut Engle was called to Pad 39A at 11 PM to witness the final closeout of the installation and pulled the Subpack boom lanyards to verify release operations of the BxA Grumman boom interface. Subpack 1 boom release operated satisfactorily and the Grumman boom pin came out as specified.

Final restowage of Subpack 2 was accomplished on 14 December 1970. During the restowage it was necessary to remove the SIDE connector cradle and to stake the rivet/pin because it fell out. Quick release (pip) pins for Subpack 2 arrived at KSC on 14 December and were installed on the subpack prior to its installation in the SLA transit container.

Subpack 2 was transported to Pad 39A and installed in LM-8 on 15 December 1970. The actual installation required approximately one hour, and the task was performed per TCP-KL-10040 without incident.

Astronaut Engle encountered difficulty during final close-out of the installation. Subpack 2 boom release operation was not satisfactory. During this operation the Grumman boom pin jammed in the BxA Grumman boom interface and could not be released. Instead of the lanyard pulling the Grumman boom pin horizontally through its axis, it was pulling with a slight lateral component of force causing the boom pin to jam. This problem was resolved by reworking the boom release attachment assembly to print on 17 December, and the Subpack 2 boom pin was successfully installed and signed-off on 18 December 1970.

Apollo 14 was launched on 31 January 1971. On 5 February 1971, the crew of Apollo 14 deployed ALSEP Array C Flight 4 on the Moon at Fra Mauro (17.48°W longitude, 3.65°S latitude).

4.2.5 ARRAY A-2

Buildup of the Central Station proceeded during February 1970, with installation and test of the harness, PDU, Receiver, and Command Decoder on the thermal plate. Central Station integration tests were completed during March, and the assembly was submitted to test for performance of Central Station verification to be followed by experiment integration. Upon completion of C/S verification, the Solar Wind Experiment S/N-7 was successfully integrated. SIDE S/N-6, a Flight Spare, was substituted for the A-2 Flight Model S/N-7 during experiment integration because SIDE S/N-7 was at Rice University for incorporation of off-latitude (leg) modifications.

The Command Decoder S/N-3 and Transmitter S/N-21 were removed from the Central Station: the Command Decoder due to direction to change the address code to that assigned to A-2 and the transmitter for EMI reduction. These objectives were achieved, and the components were reinstalled in the Central Station. A Resettable Solid State Timer, a new design for this array (replacing the mechanical design used on previous arrays) was installed. Following component installation, functional integrity of the Central Station was verified by performing a Central Station verification test and integration of the four A-2 experiments was completed. With the exception of SIDE, all experiments were those assigned to A-2 as the Flight unit.

Three components in the Central Station were scheduled for replacement; the magnesium housing transmitters S/N-21 and 24, and multiplexer S/N-13. The transmitters were scheduled to be replaced with aluminum chassis transmitters S/N-26 and 27; multiplexer S/N-13 was to be replaced with the improved design Multiplexer S/N-11. This improvement consisted of a new design to replace the multiplexer switches but retaining the existing A/D converter section of the component. This replacement should have occurred prior to Subpackage 1 assembly; however because of technical problems the components were not available at the time. To minimize the overall A-2 schedule impact, verbal authorization was provided by MSC/RALPO to proceed with the assembly of Subpackage 1, post assembly verification test, Central Station power dissipation test and the IST with the IPU. Early in April 1970, Subpackage 1 was assembled to the deployed configuration and a Post Assembly verification test was performed. Mechanical fit

checks of the SWS, PSE, LSM, RTG and ALHT were successfully completed, and a mass properties test on LSM was completed.

LSM S/N-4 was shipped to Goddard for calibration verification and then to Ames for heater power modification. This occurred on 4/9/70 with return to BxA on 4/27/70. Upon receipt at BxA, the unit was weighed and a PIA performed.

SIDE S/N-7 was returned to BxA on 15 May and fit checked to the SP #2 subpallet. It failed to fit and was returned to Rice on the same day. Corrections were made and the unit returned to Bendix 10 June 1970. A fit check with Subpackage 2 and a PIA test were successfully completed. Interim stow and assembly of Subpackage 2 was then completed.

The system IST with the IPU was completed early in May and following this test an RTG leak test was performed.

During analysis of data following the test it was noted that erroneous command verification word data resulted whenever the system was exercised with the B command address. Subsequent troubleshooting included disassembly of the Central Station and removal of the command decoder (S/N-3). PIA tests of the command decoder verified the discrepancy and isolated the fault to the control logic "B" board. The board was removed and the fault was further isolated to a defective flat pack. Disposition of the Central Station failure included replacement of S/N-3 command decoder with the flight spare unit, S/N-9. This unit required an address patch plane change from address 4A and B to 2A and B.

At the request of MSC, a study was initiated to determine the feasibility, cost, and schedule impact to modify the A-2 Array by the addition of HFE as a fifth experiment. This study, completed during the first week of June, confirmed the technical feasibility of adding the Heat Flow Experiment to the Array whereupon NASA directed Bendix to proceed with the change. Basically, the modification involved addition of a third subpackage carrying the ALSD and associated HFE hardware to mount the experiment on Subpackage #2 and modification of the Central Station harness, data processor and connector panel. The experiment was to be equipped with an "Astromate" connector to allow the Astronaut to make the connection to SP #1 during deployment on the lunar surface. The test program included qualification of the HFE Subpackage on SP 2, SP 1 qualification by "rationale", and complete acceptance testing.

Analysis indicated that system power requirement for night-time operation was near the expected output from the assigned RTG. To relieve this problem MSC made a new RTG and FCA assignment by selecting, from the remaining available units, the one capable of most power output. RTG S/N-632006 (MOD 13) and FCA S/N-633007 were assigned to A-2 in place of RTG S/N-6320012 (MOD 22) and FCA S/N-6330002. This re-assignment required repeating a series of tests which were performed on the RTG MOD 22 in conjunction with Array A-2. These tests were the Generator Acceptance test, the IPU in conjunction with the IST RTG leak test.

The ALSEP Cask Assembly for Apollo 15 arrived at KSC on 4 June, and receiving inspection was satisfactorily completed on 8 June.

The design, fabrication and procurement activities associated with addition of HFE to the Array A-2 Flight System were initiated in July of 1970. A delay was encountered in releasing the SP #1 design modification due to time required to resolve an interface problem discovered during C/S integration testing. Following installation of Command Decoder S/N-9 and Multiplexer - A/D Converter S/N-11, a Central Station verification test was performed to confirm proper operation of these two components with the system. Results of the test indicated satisfactory operation of the command decoder, but identified an interface problem between the new multiplexer design and the data processor. Investigation of this problem showed that the timing of the 90th channel pulse from the multiplexer was incompatible with generation of even frame marks within the data processor. The problem was resolved by the addition of a flat-pack to the interface between the two units. Physically, the flat pack was mounted on one of the terminal boards which was added to the A-2 Central Station in conjunction with the HFE addition. Compatibility of the interface change as proven analytically and by test. Modification of the Digital Data Processor S/N-4 Multifunction Commutator PBC was also necessary to provide the proper word assignment to the HFE. This modification was made, the component reassembled and verified by test.

Transmitter S/N-21 and S/N-24 were removed from the Central Station for replacement with Flight transmitters S/N-26 and S/N-27 during July.

A thermal analysis on SP #1 indicated that the command receiver, transmitters and PSE Central Station electronics could under certain system operating conditions be subjected to temperatures in excess of those to which they were acceptance tested. To demonstrate that this higher temperature operation would not be detrimental to the performance of these components, Bendix proposed and received MSC concurrence on 25 August 1970 to functionally test the transmitters at +150°F during the transmitter thermal vacuum acceptance tests, the command receiver at +150°F in vacuum and the PSE CSE at -10°F and +140°F at ambient pressure.

Analysis of the data from the receiver temperature test and comparison of these data with an acceptance test performed during the last part of February 1970 indicated an apparent shift in center frequency of the IF amplifier.

Acceptance testing of the A-2 transmitters S/N 26 and S/N 27 was completed. During turn-on of transmitter S/N 27 in thermal vacuum at +150 F, the 29 volt current exceeded the specification maximum of 418 ma by 4 ma for a brief period only at turn-on. This small over current represented a very small increase in the transmitter power dissipation and did not adversely affect transmitter performance or its reliability. Disposition was pursued with RALPO and MSC personnel.

Harness modifications to the Central Station, necessitated by the addition of HFE to Array A-2, were completed. Included in these modifications were the addition of telemetry to indicate which side of the data processor is in operation, a timer time-out contingency reset capability by ground command, elimination of possible ambiguity in telemetry of the HFE standby status, the data processor/multiplexer interface circuitry, and deletion of the automatic turn-on of SIDE by the 18 hour timer pulse.

A decision was made to assign Digital Data Processor S/N 4 to A-2, therefore, Digital Data Processor S/N 12 was removed from the Central Station and routed to manufacturing for retrofit to Array D.

Calibration of HFE S/N 6 was completed and the experiment assembled for a PIA.

A PDR for the Central Station electrical design modifications (SP #1) was held at Bendix on 4 August 1970.

A SP #2 FTRR was held at Bendix on 5 August 1970 as scheduled. Subsequent to this FTRR the following acceptance tests were successfully completed:

1. RTG Mod 13 Generator Acceptance.
2. Antenna Aiming Mechanism Mechanical.
3. SP #2 Mass Properties.
4. SP #2 Vibration.
5. SP #2 Magnetic Properties.
6. SP #2 Tumble.
7. SP #2 Post Vibration Boyd Bolt Verification.
8. SP #2 Fit Checks (Includes UHT's).
9. SIDE S/N 7 Post Vibration PIA.
10. RTG Post Vibration Functional and Leak.
11. SIDE S/N 7 Mass Properties.

Completion of these tests constituted completion of the Array A-2 SP #2 acceptance test program.

At the request of MSC, the ALHT S/N 1006, which was assigned to Array A-2 during the acceptance tests, was returned to MSC for modifications. ALHT S/N 1005, received at Bendix on 24 August, replaced S/N 1006 as the A-2 ALHT.

A -10°F and $+140^{\circ}\text{F}$ temperature test was successfully completed on the Array A-2 PSE CSE S/N-7. This test was performed to demonstrate performance of the PSE CSE over a temperature range in excess of that to which it is expected to be exposed during Lunar Operation.

Command Receiver S/N-8 was replaced in the system with S/N-11 because of an apparent shift in the Center frequency of the Receiver I.F. A T/V test at $+150^{\circ}\text{F}$ was performed on Receiver S/N-11 before it was installed in the C/S.

Data Processor S/N-4 was installed in the C/S following successful completion of a PIA and an interface verification test over-temperature with the Array A-2 Multiplexer S/N-11 and harness mounted interface circuitry between these two components.

Transmitters S/N-26 and S/N-27 were installed in the C/S, and continuity check-out of the modifications which were made to the Central Station harness to accommodate the HFE was completed. A harness change was also made which essentially doubled the reserve power telemetry rate. This was accomplished by connecting the two PCU ASE reserve power telemetry outputs which are provided in the basic PCU design to spare multiplex channels. This could be done since an ASE was not carried on this array.

Prior to assembly of SP #1 to the deployed Configuration, a C/S Verification test, HFE S/N-6 Experiment Integration test and a Central Station Power Dissipation Test was successfully completed. The HFE PIA was completed prior to integration with the C/S.

After assembly of SP #1 to the deployed Configuration, a Post Assembly Verification test was performed.

SIDE S/N-7 was returned to Time Zero for electrical modifications.

LSM S/N-4 was returned to ARC on 14 August 1970 for modification. Because of problems with this unit at ARC, LSM S/N-7 was substituted as the A-2 Flight Unit.

The Array A-2 System and SP #3 CDR was held at BxA on 14 September 1970.

The following acceptance tests were completed on the Array A-2 System hardware during November and early December:

1. System EMI
2. Vibration of S/P 1
3. Tumble Test
4. Magnetic Properties
5. Post Vibration MIST
6. Deployment and Open Door IST for System Thermal Vacuum Testing.

After a final visual inspection, and high voltage plug verification, the door of the T/V chamber was closed and pumping of the chamber started on 1 December 1970. Lunar morning conditions were achieved on 2 December. Problems with the IPU were encountered during the period 1-3 December, and on # December permission was granted to continue the T/V test using the RTG simulator. The T/V environments and tests were performed as follows:

12/3 Proceeding to lunar noon
 12/4 Lunar noon stabilization
 12/7 In transition to lunar night; crosstalk test
 12/9 Lunar night IST (LSM science near zero, and PSE data anomalous)
 12/10 Lunar night-to-morning transition (PSE problem cleared)

After completion of the SWS and SIDE lunar morning IST on 11 December, the chamber was opened for photo documentation of the test and retrieval of the SWE dust covers.

An open door IST of Array A-2 was performed on 12 December. In parallel with PSE troubleshooting, commands were sent to the LSM to remove and restore the digital filter. Upon removal of the filter, the science data was observed to go from near zero to saturated, indicating an inoperative digital filter (DR AB 9241). By raising and lowering the temperature of the 14 x 14 surface, the PSE anomaly was made to appear and clear, indicating that the problem was in the PSE flat cable or CSE connectors.

Because of the digital filter failure, the S/N 7 LSM was removed from the chamber set-up and returned to Ames on 14 December. All other experiments, except the PSE, were removed from the chamber. Visual inspection of the IPU disclosed charred insulation around the wires to the IPU.

On 22 December, S/P 1 and the remainder of equipment in the T/V test were removed from the chamber for mechanical measurements and X-raying of the PSE CSE connector.

The mechanical environments tests were completed by the end of January 1971.

On 1 February, the antenna aiming mechanism functional test was performed. The RTG Mod. 13 leak and functional test was completed on 3 February. PSE CSE connector troubleshooting was completed, and the S/P 1 connector interface was restored by remounting the connectors and mounting brackets.

The LSM S/N 7 incoming PIA was performed on 3-4 February. On 3 February S/P 2 was received from repainting, inspected, and two HFE Boydbolt receptacles replaced.

The Deployment Test was conducted on 9 February 1971 with Crew Representative Maj. J. Roberts performing the actual crew tasks. Numerous MSC and KSC personnel were in attendance. During the Post-Test meeting on 10 February, it was determined that the deployment had resulted in 21 TDR's, 1 DR and 8 variations to the procedure. At the request of MSC, the 21 TDR's were transferred to 20 DR's to allow tracking and proper closeout.

Per MSC direction, the SIDE S/N 7 was released to Rice University on a DD1149 and was hand carried to Rice on 11 February. Ames representatives performed the preparation for flight items on LSM S/N 7 and stowed the experiment.

On 18 February the sunshield was removed from the pallet, the specular reflector replaced, and new guywires installed to achieve proper C/S alignment and curtain draping. It was noted on 19 February that one of the four Hunter springs was dented, and this was replaced on 20 February, and SWS S/N 7 was stowed on S/P 1 after JPL replaced the burnwire cover with one which had the proper "E" and arrow.

The pretest meeting for MIST and Radiated Power tests was held on 22 February and the tests started that night. The tests were completed on 23 February and a quick look Post-test meeting was immediately called to allow stowage of S/P 1 to continue. It was learned on 24 February that the LSM had been inadvertently disconnected from C/S after the MIST, which resulted in having to repeat the LSM portion of the MIST the night of 24 February.

JPL representative replaced the SWS UHT handling socket on 24 February, with one which had dual alignment markers. The new PDM dust cover was fit checked to S/P 1 on 24 February.

During the A-2 CARR, open items to be accomplished at KSC after delivery were reviewed, discussed and scheduled with participating BxA and NASA KSC Operations personnel in attendance; the CARR culminated in a DD250 of the A-2 on 11 March.

The Apollo 15 ALSEP was air-lifted to KSC on 15 March.

Receiving Inspection of the A-2 Subpackages was completed on 17 March; DR's were initiated due to Rustrack (magnetic) recorders stopping, thermal paint chips, LSM hinge arm clip cover partially off, and pip pin pull ring bent.

The hardware kit to accomplish the thermal curtain modification (CRD's 67028, 67029, and 67030) arrived at KSC on 24 March; the modification was completed on 30 March, and the LSM was mounted to the subpackage.

BxA/KSC personnel visited Rice University on 22-23 March to inspect and subsequently hand carry the SIDE Experiment to KSC. The fit check of the SIDE dust cover was unsatisfactory, and a DR was initiated. The SIDE dust cover was modified at KSC on 31 March. Two additional DR's were initiated during the SIDE receiving inspection because of loose container pins and four untorqued screws on the bottom of SIDE. During the rework of the SIDE, it was noted that the SIDE electronics shorted to the case; SIDE was shipped to Rice to complete the rework and was subsequently returned to KSC on 1 April. Receiving inspection and the SIDE connector striping (CRD 67026) were completed on 2 April.

The PDM insulation removal modification was completed on 26 March.

The A-2 SIDE modification concerning the hinge interface of the experiment with the subpallet pedestal was accomplished at KSC by Rice University personnel on 7 April. After the SIDE was mounted on Subpackage #2, it was noted that the SIDE

connector was stowed 180° out and a DR (15 SP2-0008) was generated. Correct stowage of SIDE connector was accomplished on 8 April and DR closed.

The Flight A-2 CF² was satisfactorily performed at KSC on April 13 by Apollo 15 Astronauts Scott and Irwin. No major discrepancies were encountered. Eleven IDR's were generated against the flight hardware.

The SIDE was stowed by Rice University personnel immediately after the CF² deployment. The sunshade on the Solar Wind Experiment was removed by JPL personnel and hand carried to JPL for painting of a decal on the sun shade. The sunshade was returned and was installed on the A-2 experiment at KSC on 26 April. Installation of the SWE on the SP1 sunshield was completed on 29 April.

Flight PSE shroud was folded on 16 April in preparation for installation on the Flight PSE Sensor S/N 01.

ARC LSM personnel performed the LSM boom sensor change-out and Velcro pad rework (CF², IDR-13) on 14 April. Apollo 15 crew support concurrence was obtained on 15 April and the experiment was stowed.

Trimming of the SP #1 thermal plate thermal mask was accomplished on 15 April, and the orange depth mark striping on the HFE emplacement probe was completed on 16 April.

The S/N ACA was reconfigured with the light-weight cask on 15 April, and installed on LM 10 on 16 April for the LM 10 C²F². The Flight A2 ACA was tilted by the Apollo 15 crew on 18 April during the C²F².

A CARR meeting for PSE Sensor S/N 01 was held at BxA on 21 April. The sensor was subsequently hand carried to KSC for installation on the A-2 system.

The Array A-2 and E2-A2 SP #2 SIDE subpallets were returned to BxA on 26 April for incorporation of CCP 297. (Provide slots in the upright portion of the subpallet to enhance visibility of SIDE Boyd bolts and the addition of dust covers to prevent dust from entering Boyd bolt areas.)

The RTG Leak Test was satisfactorily completed in the MSOB on 27 April. A leak rate of 2.73×10^{-3} atm cc per second was established, well within the maximum permissible leak rate of 1.3×10^{-7} atm cc per second. However, an anomaly on the RTG Shorting Plug occurred during the continuity checks.

The following items of flight equipment was delivered to KSC by 10 May to support the 12 May Δ CF²:

1. Flight A-2 Subpallet with the Lunar Shield Modification (includes RTG Dust Cap)
2. Pull Ring for the SIDE Dust Cover.

3. RTG Shorting Plug

The PSE connector cold test was completed on 15 May 1971 at KSC. The purpose of this test was to verify proper functioning of the Sensor/SCE connectors over the range of anticipated cold temperatures.

During performance of this test, the PSE Long Period Y output was erratic. The cause for the anomaly was diagnosed as a discrepant sensor exciter. After replacing the Sensor Exciter, a re-run of the cold temperature test performed on 15 May, indicated the initial problem was corrected.

For further analysis of the exciter problem, the magnetic tapes of the connector verification test were played through the STS at BxA and PSE data were recorded. It was noted that during the transition to cold temperature on 15 May with the replacement sensor exciter, the three tidal signals, went to a D.C. level, held for approximately five minutes and then returned to normal. These findings were immediately relayed to MSC and subsequently direction was received to re-run the cold temperature test at KSC.

Re-run of the test at KSC was initiated on 11 June. On 12 June three test runs were made. One failure occurred, all tidal channels returned to D.C. level. On 13 June, three test runs were again made and three failures occurred with all tidal channels returning to D.C. level. On 14 June, the PSE connectors (2) were opened and visually inspected. Corrosion and foreign material were observed throughout the connectors. This was the first time the connectors had been opened since the start of cold temperature cycling tests on 14 May.

ALSEP SP 2 was degaussed on 1 June. Since the test results indicated that the procedure limit was exceeded, a magnetic survey of SP 2 was performed and showed a residual magnetization of 45 gamma (1 gauss = 100.000 gamma). The data obtained during the test correlates satisfactorily with the data obtained during the magnetic property test conducted in Ann Arbor. The LSM PI was in attendance, evaluated the effects on the LSM, was satisfied that the values were acceptable, and the test was satisfactorily concluded.

The cable strain relief mods on four ribbon cables were completed on 1 June. Subsequently, the SWS was mounted, the leg straightened, and the enabling plug was installed on the LSM knuckle covers, and the LSM was mounted on SP1, thereby completing stowage of SP1.

A magnetic property survey was performed on SP 1 on 3 June, and SP 1 was satisfactorily degaussed on 4 June.

Pyrotechnic lot verification tests were run on 11 June at the Field Ordnance Test Laboratory for Flight A-2 ordnance (PSE and SIDE piston actuators), and the PSE fired satisfactorily. However, the SIDE piston actuator was inadvertently fired, voiding that test; the same lot number and type SIDE ordnance was forwarded to KSC from Rice University, and fired satisfactorily.

Subpackage #1 was returned to BxA, Ann Arbor, on 17 June for replacement of the PSE connectors which were degraded as a result of temperature cycle testing. The connectors were replaced and verified over temperature using GN₂ to prevent condensation and contamination. All other Subpackage #1 experiment connectors were examined and cleaned as required. After re-mating all connectors, the Subpackage #1 system was verified by performing a MIST and Radiated Power Test.

During installation of Boyd bolts in Subpackage #2 at KSC on 21 June, the spindle in a Boyd bolt, which was being installed, fractured. As a result of this failure, and a rather detailed investigation of Boyd bolts in general, a decision was made to completely rework all Boyd bolts for Array A-2 and implement measures to preclude procurement of deficient bolts and prevent or greatly reduce the possibility of incorrect installation. New bolts were installed in Subpackage #1 at BxA in accordance with improved procedures and a new tool designed to properly position the bolt in the receptacle. New bolts, tool, and procedure were forwarded to KSC on 28 June for use in installing the bolts in Subpackage #2.

The Apollo 15 Flight Readiness Review was held at KSC on 24 June. Significant ALSEP Flight A2 open items on the agenda under discussion during the FRR included Boyd Bolts, the PSE connector (J-35) and associated green/blue contamination, and the possibility of EMI problems if the Lunar Communication Relay Unit (LCRU) antenna is pointing toward the area of the deployed ALSEP on the lunar surface. The LCRU/ALSEP item was handled in a procedural manner to preclude EMI problems.

A new set of Boyd bolts were installed on SP 2 on 2 July using the new procedure and tool and was completed without encountering any problems.

Flight A-2 SP 1 arrived at the KSC on 2 July, and receiving inspection was completed without any DR's being initiated.

Final preparations for flight for both subpackages were completed on 6 July. A satisfactory caging pressure check was performed on the PSE. Subsequent to loading, the PSE lockout connector was removed and the PSE was vented.

Apollo 15 ALSEP flight hardware, consisting of SP 1, SP 2, and ACA was satisfactorily installed on LM-10 on 7 July. Loading began at 0900 with Subpackage 2 followed by Subpackage 1, and the ALSEP Cask Assembly.

Closeout photographs were taken of all ALSEP flight hardware after installation and buy-off by Apollo Astronaut Parker prior to closing the SEQ Bay door in LM Quad 2 on 8 July.

A check was performed on the ACA baroswitch utilizing the LM telemetry system to the KSC ACE control room. This particular test exercised the baroswitch with a vacuum line and the upper band temperature sensor with a heat gun.

The dummy FCA was installed in the Flight A-2 ACA during the Apollo 15 CDDT on 12 July. The ACA protective cover was reinstalled on the ACA on 14 July

during recycle after the 525 platforms were installed. The operation was satisfactory and no DR's were generated.

The final ACA baroswitch check was performed on 16 July. The Fuel Cask Assembly was installed on 25 July. The temperature sensor on the ACA stabilized at 151°F after two hours. After GN₂ switchover at 7-9 hours in the countdown when hydrogen/oxygen fill began, the ACA temperature stabilized at 146°F.

Apollo 15 ALSEP A-2 System was launched on 26 July 1971 and deployed on the moon at Hadley Rille on 31 July 1971 by astronauts Scott & Irwin. At 1850 Gmt, shortly after initial alignment of the antenna, data lock was obtained at the Canary Islands ground station. Conditions of the Central Station and power units was normal.

5. RESULTS

The ALSEP program has been fully successful in establishing durable long life stations on the moon. The three Arrays covered in this report continue to operate: each has significantly exceeded its required operating life-time.

Scientific results of each Apollo mission are covered in reports prepared by NASA with a "Preliminary Scientific Report" published for each Mission. Therefore, this section will summarize the non-scientific aspects of each ALSEP System.

5.1 ARRAY A

Array A equipment was stored in the SEQbay of the LM and carried to the moon on Apollo 12 on 19 November 1969. The equipment was deployed at Oceanus Procellarum (23.5° West and 3.0° South). Immediately following activation by the Astronaut, the telemetry data signal was received by the STDN (formerly MSFN) station and forwarded to the mission control center at Houston. Evaluation of the telemetered information showed all parameters within acceptable limits.

Performance of the Array A station is summarized in Table 12.

5.2 ARRAY B

The array B system was lost when the Apollo 13 landing was aborted due to an explosion in the Service Propulsion System.

5.3 ARRAY C

Array C equipment was carried to the moon on Apollo 14. On 5 February 1971, the equipment was deployed at Fra Mauro (17.5° West and 3.7° South). Shortly after deployment the systems were activated by the Astronaut to send the telemetry signal on its way to Earth. Review of the telemetry data, as received at MCC showed all parameters to be within acceptable limits.

Performance of the Array C Station is summarized in Table 12.

5.4 ARRAY A-2

Array A-2 equipment was carried to the moon aboard Apollo 15 and on 31 July 1971 was deployed by Astronauts near the Hadley Rille at 3.7°E. longitude and 26.1°N. latitude. Following activation, telemetry data received at MCC was analyzed and confirmed that all operational parameters were within normal limits.

Performance of the Array A-2 station is summarized in Table 12.

**TABLE 12
ALSEP OPERATIONAL STATUS
27 AUGUST 1973**

	APOLLO 12 ALSEP	APOLLO 14 ALSEP	APOLLO 15 ALSEP	REMARKS
Deployed	19 Nov. 1969 1412 GMT	5 Feb. 1971 1728 GMT	31 July 1971 1805 GMT	
Operating Life (Specification)	One Year	One Year	One Year	
Operating Life (Actual to 8/27/73)	1377 Days	934 Days	758 Days	
RTG Output Power				
Initial	73.6 Watts	72.5 Watts	74.7 Watts	
Present (8/27/73)	66.9 Watts	69.0 Watts	71.5 Watts	
Reserve	11.5 Watts	18.8 Watts	10.5 Watts	Lunar Night Operation
Function Control Commands Processed (to 8/27/73)	17,969	10,081	17,806	
Central Station				
- Digital & Analog Data Processors	Operational	Operational	Operational	
- Command Decoder	Operational	Operational	Operational	
- Receiver and Transmitters	Operational	Operational	Operational	
- Power Conditioning and Distribution	Operational	Operational	Operational	
- Timer	Failed	Failed	Operational	Failure does not de- grade system oper- ational
Experiments				
PSE	Operational ¹	Operational ¹	Operational ¹	
SWS	Operational ¹	N/A	To Standby 3/21/73	
LSM	Operational ¹	N/A	Operational ¹	
SIDE/CCGE	Operational ¹	Operational ¹	Operational ¹	A12 CCIG failed
CPLEE	N/A	Operational ¹	N/A	
ASE	N/A	Thumper Only ²	N/A	
HFE	N/A	N/A	Operational ³	

Notes: 1. The instrument is currently operating although anomalies have occurred. These are documented and tracked by use of NASA "Span Mission Evaluation and Action Request" (SMEAR) forms.

2. ASE motors have not been fired.

3. Probes were not deployed to the proper depth, however, the experiments operation is fully successful.

APPENDIX A

LIST OF
ALSEP TECHNICAL MEMORANDUMS

(ATM)

ALSEP TECHNICAL MEMO

Number	Title
1A	Outline -ALSEPManufacturing Plan
2	ALSEP -Experiment Equipment Requirements
3A	ALSEPIntegrated Test Plan - Scope Objectives
4A	ALSEPMockup Specification
5	MSC Critique of Bendix Proposal
6	ALSEPReliability Program Plan
7	ALSEPTest Plan Scope Objectives
8	ALSEPQualification Plan System Test
9	ALSEPSystem Concept
10	ALSEPExperiment Interface Allocations
11	Tools Required for Emplacement of Lunar Surface Experiments
3A	ALSEPIntegrated Test Plan & Outline
12	ALSEPReview of System Requirements on Experiments
13	LGE Reference Design
14A	ALSEPExperiment Combinations
15A	ALSEPGround Operations Plan - Checkout Logic & Flow
16	Parametric Reliability Data
17	Evaluation ofALSEPGravimeter Thermal Design
18A	Review of TRW TAPLE Report
19A	RTG Report Review
20	ALSEPGravity Experiment; Bell Aerosystems Instrument
21	ALSEPExperiment Interface Conflicts
22	Data Survey Memo - Task 3.1.4.1A
23A	Phase IIALSEPDocument Requirements List
24	ALSEPQuality Program Plan - Detailed Outline
25	Reliability Goal - Power Supply
26	ALSEPSystem Concept Selection
27	GSE Development & Test Plan - Scope Objectives & Logic
28	Data Subsystem Preliminary Functional Requirements
29	Definition of Ground Support Equipment
30	Preliminary Manufacturing Flow Charts (BSX-2626)
31	Johnson Proposal Evaluation

ALSEP TECHNICAL MEMO (Cont.)

Number	Title
32A	Preliminary Human Factor Requirements
33	Link Analysis for Alsep
34	Communications System Performance
35A	Alsep PCM Telemetry Format
36	Structural Thermal Subsystem Requirements
37	GSE Requirements Document
38A	Gross Mission Functional Analysis
39A	Preliminary Parameter Allocation Spec.
40A	Interim Performance & Interface Spec.
41	Draft-Section 7.0 - Manufacturing Controls of Alsep Manufacturing Plan
42	Alsep Preliminary Test List
43	Initial Alsep Reliability Prediction
44A	Subsystem Reliability Goals
45A	Configuration Management Report, Mass Properties and Materials
46	Master Schedule, Preliminary
47	Preliminary Study of Data Storage Requirements for Alsep
48	RTG Interface Definition
49A	Alsep Training Plan Outline
50	Alsep Reliability Program Plan - Reliability Engin- eering Activities
51	Materials
52A	Thermal Coating Evaluation
53A	Alsep Support Plan Outline
54	Alsep Test Description, Task 3.1.5.9.2
55	Redundancy in Data Subsystem
56A	Mission & Crew Engineering Plan Outline
57	Engineering Plan-(Customer Liaison)
58A	PG&C Subsystem Requirement Memo (Preliminary)
59	System Test Considerations (3.1.5.10.2)
60	Management Plan
61	Make or Buy Analysis
62	Component Test Considerations
63	Component Test Criteria

ALSEP TECHNICAL MEMO (Cont.)

Number	Title
64A	Experiment Cabling Characteristic
65	Alsep Antenna Orientation
66	Preliminary Maintenance Concept Memo
67	Facilities Plan - Outline
68	Deliverable Hardware List - Manufacturing Plan
69	GSE Requirements, Task 3.1.5.11.4
70	Description of Pre-launch Checkout
71	Alsep Antenna Design
72	Preliminary Mockup Drawings
73	Manufacturing Reports - 3.1.5.18.7
74	Configuration Management Scope and Objectives 3.1.5.19.1
75	Ground Operations Plan - 3.1.4.11.1
76	Configuration Management Plan (Engineering Records Control Procedures)
77	I & I Subsystem; Sensor Analysis - 3.1.2.3 (A1)
78	Housekeeping TM Requirements - 3.1.2.3 (B1)
79A	Alsep Reliability Program Plan - Parts and Materials Program - 3.1.5.13.3
80	Antenna Optics-Sun Interference
81	3-D Mockups - 3.1.4.2A
82	PG and C Subsystem Interface Specification - 3.1.2.4C
83	Test Description (GSE) - 3.1.5.12.2
84	Experiment Preliminary Design
85	Review of Material Requirements for Alsep - 3.1,2.2., B2
86	Quality Program Plan - Quality Control - 3.1.5.14.2
87	Appendix to Link Analysis for Alsep
88	Antenna Optics Sun Interference
89	Experiments Cabling
90	Data S/S Preliminary Design
91	Reliability Prediction No. 2
92	Fuel Cask versus Integrated RTG Evaluation
93	Tentative Command Sequence for Alsep
94	Preliminary Analysis of Mechanical Environmental Effects on Alsep from LEM (unscheduled ATM)
95A	Release of Hard Mockup Layout

ALSEP TECHNICAL MEMO (Cont.)

Number	Title
96	Preliminary Operational and Maintenance Functional Flow
97	Management Plan - Design & Staffing Controls 3.15.2.5 & 2.6
98A	Management Control Plan - Responsibility and Description
99	Thermal Test Requirements & Plans
100A	Vendor Evaluation for Transmitter & Receiver Task 3.1.21 B2
101	EMI, RFI and Grounding Specification - Task 3.1.2.1 D6 11/10/65
102	Vendor Selection Criteria - 3.1.5.7.3
103	Reliability Program Plan - Organization and Program Control - 3.1.5.7.3
104	A Review of Thermal Coating Materials-3.1.2.2.A1
105	Integrated Test Sequence & Schedule - 3.1.5.8.3
106	Cancelled
107	Study of Antenna Erection & Pointing - 3.1.4.2B
108	Phase I Alsep M&E Test Program Plan-3.1.4.2B
109	Alsep Experiments Thermal Control Preliminary Design-3.1.3.4A
110	Alsep GSE Hardware List-3.1.5.12.4
111	Acceptance Checkout Equipment (ACE) Utilization on the Alsep Program
112	Hand Carry Transportation Modes
113	Preliminary Test Sequence & Schedule (Development)- 3.1.5.9.3
114	Test Plan Hardware List-3.1.5.9.4
115	GSE Test Sequence & Schedule-3.1.5.12.3
116	Alsep Component and System Qualification Schedule 3.1.5.10.3 and 3.1.5.10.9
117	Reliability Program Plan Section 6.0 Subcontractor Control - 3.1.5.13.5
118	3-D Mockup Evaluation
119	Phase II Manufacturing Problems, 3.1.5.18.9

ALSEP TECHNICAL MEMO (Cont.)

Number	Title
120	Sub Bit Encoding Evaluation
121	Support Requirements for Development Test Plan Task 3.1.5.9.5
122	Management Control Plan - Subcontractor Statement of Work
123	Cancelled
124	Make or Buy Plan - Vendor Survey
125	Experiment Mockup Drawings
126	Experiment Interface Drawings
127A	Quality Program Plan-Quality Management 3.1.5.14.3
128	Draft - Manufacturing Plan - Section 8.0
129	Human Factors Tests of Antenna Erection, Standing Position
130	GSE Test Plan, Support Requirements 3.1.5.12.5
131	Qualification Test Equipment Requirements 3.15.10.4
132	Transportation Modes Analysis
133	Test Schedules, Ground Test Plan 3.1.5.11.7
134	Human Factors Test and Evaluation of Various RTG Fuel Transfer Tool Handling Configuration
135	Cask Tilt Angle Study
136	Human Factors Test of Antenna Erection, Kneeling Position, Lowered Sight
137	Human Factors Test of Hand Carry Alsep Transportation Mode
138	Draft-Phase II Manufacturing Problem Solutions 3.1.5.18.11
139	Alsep Logic Techniques Study
140	Configuration Management Plan (Top Assembly and Interface Control) 3.1.5.19.3
141A	Make or Buy Plan - Evaluation Criteria - 3.1.5.7.5
142	Experiment S/S Specifications
143	Documentation Plan - Recommendations 3.1.5.6.7
144	Experiment Cabling Deployment
145	Data Subsystem Reliability, Standard IC versus MOS
146	Alsep Ground Operations Plan, Facilities Require- ments, Task 3.1.5.11.5

ALSEP TECHNICAL MEMO (Cont.)

Number	Title
147	Alsep Ground Operations Plan, Test Parameters and Acceptance Criteria, Task 3.1.5.11.6
148	Reliability Program Training and Indoctrination 3.1.5.13.6
149	Ground Operation Plan, Special Test Equipment 3.1.5.11.12
150	Uplink Compatibility Study
151	Discussion of Two Antenna Approach to Alsep Data Subsystem
152	Post Qualification Test, Task 3.1.5.10.5
153	Downlink Multipack Loss, Task 3.1.2.1D
154	Uplink Performance Analysis
155	Central Station Thermal Control
156	GSE Configuration for Factory Test and KSC Operations
157	Component Qualification Status, 3.1.4.10.8
158	Manpower Requirements 3.1.5.11.8
159	Study & Test of Reach Parameters Unloading Alsep from LEM 3.1.4.20
35B	Alsep PCM Telemetry Format
160	Alsep Reliability Program Plan - Reliability Evaluation Procedures, 3.1.5.13.7
161	Make or Buy Plan - Recommendations on Sub-contractors Proposals 3.1.5.76
162	Facilities Plan - Section 3.0 - Manufacturing Facilities Requirements
163	Draft - Section 9.0 - Alsep Manufacturing Plan-Tooling Requirements
164	GSE Engineering
165	System Cost & Schedules 3.1.5.20.9
166	Alsep Integrated Test Plan
167	Preliminary Maintenance Functional Analysis
168	Facilities Plan - Test, Quality Assurance and Support Requirements
169	Manufacturing Plan Test Support
170	Engineering Plan
171	Subsystem Cost & Schedules 3.1.5.20.10

ALSEP TECHNICAL MEMO (Cont.)

Number	Title
172	Facilities Plan - Identification and Resolution of Facility Problems
173	Draft - Manufacturer Flow Chart - Section 5.0 of Manufacturer Plan
174	Cancelled
175	Experiment Cost & Schedules - 3.1.5.20.11
176	Draft - Manufacturer Plan - Section 6.0 - Manufacturer Facilities Requirements
177	Configuration Management Plan, Change Control Procedures - 3.1.5.19.4
178	Cancelled
179	Preliminary GSE Configurations for Major Levels of Alsep Testing
180	Alsep Criticality Analysis - 3.1.1.4D
181	Alsep Downlink Data Characteristics
182	Alsep Initial Startup Procedure
183	Reliability Program Plan - Schedules and Manpower - 3.1.5.13.9
184	Qualification Plan Hardware Flow Chart
185	Subcontractor Schedules - 3.1.5.3.7
186	Subcontractor Costs - 3.1.5.3.8
187	Cost Estimate Forms - 3.1.5.5.3
141A	Make or Buy Plan - Evaluation Criteria
188	Alsep Test Department Organization and Responsibilities - 3.1.5.11.9
189	Mockup
190	GSE Equipment Description
191	Field Evaluation of Hard Mockup Memo - 3.1.4.2D
192	Technical Support Plan - 3.1.5.15.5
193	Mission & Crew Technical Plan - 3.1.5.20.15
194	Technical Training Plan - 3.1.5.16.3
195	ALGE Utilization - 3.1.4.1D
196	Sun Shield Erection
197	Human Factors Evaluation of Descent Stage Stowage Compartment Door Redesign GAEC
197P	Test Data Format - 3.1.5.11.10

ALSEP TECHNICAL MEMO (Cont.)

Number	Title
198	PERT & Companion Cost Plan - 3.15.4
199	Antenna Siting - Unscheduled
200	Experiment Tie Down - Unscheduled 3.1.4.2B
201	Proposed Power Conditioning Unit Design
202	Experiment Engineering Plan - 3.1.5.20.12
203	Alsep Maintainability Characteristics
204	Safety Requirements - 3.1.5.11.11
205	Cable Deployment
206	Experiment RFI Specs.
207	Antenna Pointing Technique
208	Judgment of Distance and Use of Aids on the Lunar Surface
209	Visual Considerations & Sun Shield in Alsep Lunar Deployment
210	Human Factors & Maintainability for GSE
211	Lunar Checkout & Crew Activity
212	Reliability Program Plan - Documentation-3.1.5.13.8
213	Justification for 85' Antenna - B011404, B011413
214	Presentation of Alsep Central Station Thermal Design
215	Mounting of RTG Fuel Element Cask to LEM
216	Comparative - Analysis of Thermal Conditioning Methods for the Alsep Central Station
217	Alsep Central Station Thermal Test Program Presentation
218	Alsep Experiments - Thermal Control
219	Passive Seismometer Mounting
220	Status of the Structural Design for the Alsep
221	DC Isolation of Suprathermal Ion Detector Experiment
222	Time Identification of Data
223	Revised Alsep Weight Allocation
224	Alsep Thermal Subsystem Thermal Test Results
225	Data Processor & Command Decoder
226	Data Processor Functional Description
227	Final Evaluation of Modulation Forms for the Alsep Downlink

ALSEP TECHNICAL MEMO (Cont.)

Number	Title
228	Influence of Variations in MSFN Rear Loop Band-Width on Alsep Downlink
229	Design of PCU
230	Summary of Current Status of GFE
231	Thermal Test Results
232	Facilities Plan - Plant 2
233	Experiment Test and Checkout Information
234	Dynamic Analysis Summary
235	Transmission of Engineering (Housekeeping) Data During the Active Seismic Mode
236	Data Subsystem Cabling
237	SEB Results - Alsep Receiver, Duplexer, Transmitter
238	Alsep Program Testing Requirements
239	Effect of Substitution of Normal Oxide for Depleted Oxide in RTG (Action Item B040105)
240	Gravimeter Experiment Interfaces
241	Acceptable Parts List
242	Approved Materials List
243	Mode, Effects & Criticality Analysis (FMECA) Instructions for Use in Conducting Failure
244	Lunar Surface Verification Tests for Charged Particle Lunar Environment Experiment
245	Results of an Experiment to Evaluate the Ball Joint Base Antenna Design
246	Inspection & Calibration for Experiment Test Sets
247	Transmission-Circuit Losses
248	Limiter Degradation
249	Suggested Experiment Test Set Configuration
250	Downlink Power Budget for Comparing Subcarrier and Split Phase Modulation
251	Data Degradation Due to Carrier Demodulator VCO Bandwidth Variation
252	System Test Set/Suprathermal Ion Detector Data Interface
253	Block I and II Mechanical & Thermal Design
254	Alsep Structural Design & Loads Criteria
255	Alsep Engineering Drawing Control Procedure

ALSEP TECHNICAL MEMO (Cont.)

Number	Title
256	ALSEP Power Conditioning Unit Requirements
257	ALSEP Carrier Frequency Allocation vs Modulation Type
258	ALSEP Data Subsystem Test Parameter
259	ALSEP/LEM Equipment Interface
260	Picket Fence Component Structural Test Procedure
261	Data Subsystem Test Set Preliminary Design Specification
262	Telemetry Frame Format
263	RFI Enclosures for Equipment Test Set
264	GSE Interface for Heat Flow Experiment
265	Revision of ALSEP Receiver, Transmitter and Diplexer Transmitter
266	Request for Revision of Naco Proposal No. BG721-27-6-387P Apollo Lunar Surface Drill
267	Revision of ALSEP Antenna Assembly Spec.
268	Mass Property ALSEP Systems - May
269	Telemetry List
270	Command List
271	Interim Technical Report Task 3
272	A study of ALSEP Antenna Pointing
273	Requirement for TRG to PCU Cable Action B041608
274A	ALSEP Reliability Math. Model Prediction
275	ALSEP Sun Compass Error Analysis
276	Computer Control Logic Selection
277	Definition of "Most Significant Bit First"
278	Structural Design Criteria
279	Action Item B6-0519-25B
280	Structure Test Plan, Bl. 1 ALSEP Dynamic Tests
281	ALSEP Phase II Thermal Test Requirements
282	Response to Action Item B6-0518-08B
283	Exp Cable Weights
284	Subsystem Electronic Interconnection List
285	ALSEP Command Decoder - Output Pulse Characteristics
286	Action Items on Geophone and Amplifiers
287	Interface Definitions
288	ALSEP System and Exp. Initialization
289	ALSEP Exp. Power Light, and Protection
290	Hardware requirements on the System Test Set Action Item B6-0518-19B

ALSEP TECHNICAL MEMO (Cont.)

Number	Title
291A	Response to Action Item B6-0518-09B
292	S-Band Compatibility Test In Response to Action Item B051301
293	Scheduled Impact of Data Subsystem Subcontracts
294	Magnetic Cleanliness Guidelines
295	LEM Exhaust Effects
296	ALSEP Internal Wiring
297	Calibration Test for Charged Part B6-0526-03B Lunar Environment Exp.
298	GSE Ordnance Test Set
299	Proposal for Transient Pressure Engineering Measurement
300	ALSEP Gen Familiarization Manual Special Outline
301	Human Factors Requirements RTG/PCU Connectors
302	Recommendation on Exp. Self-Leveling Mechanism
303	Never Issued
304	Measurements List
305	Response to Action Item B6-0519-24B
306	Lunar Pri & Secondary Mel. Flux Buildup on Thermal Control Surface
307	Response to Action Item B6-0602-07B
308	Response to Action Item B6-0602-09B
309	Intra Subsystem Cabling Requirements
310	Safety Requirements
311	Intra Control Wiring Color Code
312	Multi Purpose Tool
313	Interface Definitions
314	ALSEP Active Seismic Experiment Thermal Control
315	ALSEP Passive Seismic Experiment Thermal Control
316	Action B6-0602-26B System, Subsystem & Exp. Power Profile
317	Res B60602-31B RTG Cask and Fuel Capsule Handling on KSC
318	Plan for Merging Develop Design of Act Seismic Exp into the exiting Bendix design
319	Prel. Results of Flat Conductor Cable Mech. Tests
320	Prel. Results of Flat Conductor Cable Cross Talk Tests

ALSEP TECHNICAL MEMO (Cont.)

Number	Title
321	ALSEP Central Station Thermal Control Design
322	ALSEP Dynamic Test Plan
323	ALSEP Maintenance Concept (Replace ATM-66, Phase I)
324	Circuit Overload & Problems Associated with Commanding Mode Changes
325	ALSEP General Interface Requirements Document
326	ALSEP Experiment Power Control
327	Consideration Actions for Providing Multiple Voltages to ALSEP Experiments
328	Review of Heat Flow Design Concept Spec.
329	Review of Performance/Design Product Config. Requirements Simulator, Thermal/Mech - ALSEP Lunar Thermal Ion Detector Experiment
330	Plan for PI Analyses of PI Design for SIDE
331	Objectives of System Engineering Review of Brassboard Tests
332	Evaluation of Parameters Affecting Selection of Operating Frequency for Active Seismic Experiment
333	EMI Protection Design Guidelines
334	Justification of 10 ft Separation between RTG & Central Station
335	Flat Conductor Cable Evaluation Report
336	Phase I Design Evaluation
337	Antenna Offset Alignment Techniques
338	Magnetometer Experiment Power Profile
339	Action Item B6 0615-16B
340	B6 0615 - 17B & B6 0615 - 35B
341	Selection of Flat Conductor Cable & Connectors for ALSEP Interconnection Cables
342	Flat Conductor Cable EMI Tests
343	Termination of "H" Flim Insulated Flat Conductor Cable
344	Relays vs Silicon Controlled Rectifiers Reliability Comparison
345	Qualitative Reliability Considerations on the Active Seismic Experiment
346	Formerly ATM 38 - ALSEP Mission Operational & Task Analysis

ALSEP TECHNICAL MEMO (cont.)

Number	Title
347	Qualification Status List - Executive Instruction
348	Huges Connectors
349	Flat Cable Abrasion Test
350	Mission & Crew Engineering Category I Test Report
351	Results of Flat Conductor Cable Hi Temp Tests
352	List of GSE to be delivered to KSC
353	Method of Reproducing Magnetic Tape Recording for PI
354	Flat Conductor Cable - Background Information
355	Evaluation - Active Seismic Experiment Preliminary Mission Crew Engineering
356	Response to Action Item B6-0615-36B Minutes of Monthly Progress Review June 1966
357	Flat Cable Spool Design
358	Reliability Analysis Data Subsystem Timer/Sequencer
359	Failure Rate Modifiers ALSEP Inoperative Phases
360	Evaluation of Interface Circuits
361	Connector for Flat Conductor Cable
362	Stress-Release for Flat Conductor
363	EMI Test Plans
364	Changes in the Magnetometer Interface Control Spec.
365	Active Seismic Experiment Prelim. Design Review
366	Optical Light - Conceptual Design
367	ALSEP Logistic Status Report July 1966
368	Brassboard Hardware Availability for Preliminary S-Band Compatibility Test
369	Command List
370	Telemetry Measurements List
371	Need for Vacuum Chamber for CPLE Experiment During System Test
372	Crew Turn-On Activity
373	Local Oscillator Rejection for ALSEP Data S/S
374	Housekeeping Data During Active Seismic Load
375	Data Subsystem Internal Wiring Brassboard
376	Reliability Comparison of 2 ALSEP PCU Concepts

ALSEP TECHNICAL MEMO (Cont.)

Number	Title
377	Immediate Weight Reduction Targets
378	Effects on Data Subsystem of a Momentary Power Dropout
379	Packing of Central Station Event Measurements
380	Subsystem PDR Problem Resolution
381	ALSEP Experiment Power Distribution Protection
382	Definition of Nominal Made for Experiments
383	Power Distribution & Signal Conditioner-Cross-Talks & Common Mode Rejection
384	Flat Conductor Cable Revised Weight Estimate
385	Overload Protection to Flight Hardware
386	Definition of Diagnostic Testing for Charger Particle Experiment Test Set
387	Weight Power Analysis of Superthermal Detector Experiment
388	Preliminary Thermal Analysis of Lunar Surface Magnetometer
389	Progress Report Fault Insulation for Passive Seismic Experiment
390	Data Degradation in a Phase Log-Loop w/direct Carrier Modulation
391	Response to Action Item B6-0630-03B Provision Flight Cable/Jumper Cable Protection
392	System Test Set - Fault Isolation & Steering Philosophy - Response to Action Item B6-0630-05B
393	Response to Action Item B6-0701-03B GSE/Electronic Connectors
394	Magnetic Cleanliness Evaluation Report
395	PDR Synopsis - Systems Session (13)
396	Plan for Operational Contingency Study
397	Response to Active Seismic PI's Magnetic Field Cleanliness Request
398	Prel. Inrest. to Determine Accuracy of Temp Measure on RTG Hot Plate
399	ALSEP System Test Requirements
400	Physical Problems in Installing Fuel Cask in LEM-Resp to Action Item B6-0602-31B

C-3

ALSEP TECHNICAL MEMO (Cont.)

Number	Title
401	Specs of Geophones for Active Seismic Experiments B6-0711-04B
402	LEM Weight Reduction
403	SIDE/ALSEP Design and Deployment Action Item B6-0712-28B
404	Power Profiles
405	Response to Action Item B6-0712-14B
406	Distribution Unit-ALSEP Control Station Magnetic Latching Relays to be Used in Power
407	Determination of Capsule Handling Tool -- Lacking Concept
408	Fair Trialed Low Powered DTL Microcircuit Derating Investigation
409	Resolution of PDR Change Request #2-05
410	Provision of Jumper Cable for Ground Testing
411	Data Subsystem Grounding Philosophy
412	Evaluation of the North American Apollo Tool Kit
413	Preliminary Weight Estimate for SIDE/CCGE
414	Interconnecting Cable Deployment Procedures
415	Alsep General Familiarization Manual, A Preliminary Manuscript
416	Engineering Model Test Plan Programming Schedule
417	Active Seismic Detection System Interface B6-0712-34B
418	Parts and Materials Test Plan
419	Data Processor Multiplexer Converter - Low Input Impedance
420	Telemetry Sync Code
421	Flat Conductor Cable Reel Dimensions
422	Alternate Antenna Pointing Concept
423	Alternate Antenna Pointing Concept Schedule
424	Flat Conductor Cable Cross Talk and EMI Character- istics of Spooled
425	Cross Talk in Flat Conductor Cable with Low-Frequency Sine Inputs
426	Sun Compass Geometrical Errors
427	Alsep Logistics Status Report - August 1966
428	Heat Flow Exp.

ALSEP TECHNICAL MEMO (Cont.)

Number	Title
429	Heat Flow Exp.
430	Heat Flow Exp.
431	Location of Cable Bobbins as Part of Experiments
432	Connectors and Test Configurations
433	Integration Central Station Brassboard
434	Design Constraints on Command Decoder - Phase Locked Loop
435	Functional Test of Active Seismic Geophone Amplifier During System
436	Clocked Flip-Flop Analysis of Fairchild LPD TUL 9040
437	Control of Interface Signals
438	Alsep Flight System and System Test Set Field Maintenance Manual, Topical Outline
439	Attenuation of the Multiplayer Sun Signals Command De-Coder Phase Locked Loop
440	Alsep Central Station Timer
441	Lunar Geological Equipment
442	Array "A" Exp Data Formats for use in Alsep System Testing
443	Data S/S RF Equipment Antenna - Connected EMI Requirements for
444	Act. Seismic Frame Synchronization
445	Alsep Fuel Cask Thermal Shield
446	SIDE/CCIG Weight Breakdown
447	Action Item B6-0707-02B
448	Action Item B6-0712-32B
449	Alsep Power Budget 12 August
450	B6-0712-31B
451	B6-0805-11B
452	Alsep Central Station Reflection Test Requirements
453	Central Station Power and Thermal Balance
454	Preliminary Results from Bendix Dynamic Analysis
455	Alsep Stowed vs. Deployed Arrangement Temperature Window B6-0805-4B
456	Act. Seismic Detection System
457	Guide for the Preparation of Alsep Summary Analysis Forms
458	B6-0805-8B

ALSEP TECHNICAL MEMO (Cont.)

Number	Title
459	ASE Data Format B6-0805-5B
460	Investigation of Leveling Leg Requirements
461	Alsep Antenna Pointing Composition Error Analysis
462	Condition Power for Act. Seismic Exp.
463	Active Seismic Word Format Comparison
464	Preliminary Evaluation of PIE20 Electric B6-0805-6B Transducer (Small) for Thumper
465	Action Item B6-0805-7B
466	Action Item B6-0712-25
467	Control of Pulse Rise and Fall Times With Fairchild Logic Circuits
468	Flat Conductor Cable Expansion from Lunar Day to Lunar Night
469	TCU Transient Response Characteristics
470	Passive Listening Mode for Act. Seismic Exp.
471	Philosophy for Electronic Modules Fastener Tie-Down and Tooling Plate Design
472	Grenade Transmitter Operational Verification Tests
473	List of Alsep Connectors
474	Heat Flow Error Analysis for Posemon Engr.
475	Sun Angle Limits During Deployment
476	Thermal Door Detector Exper. (SIDE) Preliminary Thermal Analysis of the Supra
477	Thermal Analysis of the Alsep Thumper
478	HFE - Electronic Systems Analysis for Dynatronics
479	Critique GE Test Plan - B6-0817-04B
480	Parts and Materials; Parts Application Analysis Documentation B6-0817-22B
481	Evaluation of the Short Backfire Antenna
482	Preliminary Thermal Analysis of Dust Detection
483	Exp. Electrical Interface Definitions
484	Alsep System Grounding Philosophy B6-0847-013B
485	Supplement to ATM 468 - Flat Conductor Cable Expansion from Lunar Day to Lunar Night
486	Alsep Screening Test
487	Requirements for KSC Ancillary Equipment B6-0817-28B
488	ASE Central Cable Connectors
489	ASE Geophone and Cable Deployment and Emplacement

ALSEP TECHNICAL MEMO (Cont.)

Number	Title
490	Magnetometer Human Factors Test Support
491	B6-0817-025B - Energy Loss by Baffles and Thumper
492	Alsep System Orientation Manual
493	Alsep Cable Thermal Test
494	Leveling Leg CPLEE Design Concept for the Model of the CPLEE
495	Summary of Tests Plan for Prototype
496	Alsep Logistics Status Report - September
497	Alsep Flight System and Ground System Familiarization Manual; Topical Outline
498	Data S/S Baseline - Command User List
499	B6-0817-10B - Bx Data Requirements During Lunar Operations
500	Circuit Design Capacitors Using Solid Tantalum
501	Failure Modes, Effects, and Criticality Analysis
502	Composite Parts List
503	Evaluation of Thermal Barrier Materials
504	Active-Seismic Exp Test Plan
505	Development of Space Thermal Simulation Techniques for Alsep
506	Lunar Operations Monitoring Schedule
507	Alsep Parts Data Book
508	Review of Performance Spec for Exp SIDE/CCGE
509	Magnetic and Electric Field Cleanliness Status
510	K6-0907-02B ASE Detail Data Package for KSC
511	Exp. Turn-on Sequence
512	Prelim. Copies of Engr Model Test Plans
513	Commanded Momentary Power Demands
514	Prelim. Thermal Analysis of Solar Wind Exp
515	Measurement of Magnetic and Electric Field Cleanliness and R. S. I. of Alsep Components
516	Data Subsystem/Lunar Surface Mag. Simulator Integration Tests
517	Heat Flow Dummy Probe Availability
518	Human Factors Mock-up - Alsep Antenna Aiming Mechanical B6-0921-24B
519	Power Reset Circuit for the Data Processor

ALSEP TECHNICAL MEMO (Cont.)

Number	Title
520	Heat Flow DLA Thermal and Structural Model Schedule
521	Materials Construction Technology of the RTG Cable
522	Engrg Model Test Data Flow to Succeeding Model Releases B6-0921-25B
523	Draft: Alsep Magnetic Cleanliness Tests
524	Alsep Mechanically Actuated Switches
525	B6-0921-28B - Bulova Acutron Reliab.
526	Experiment Leg Designs - B6-0921-12B
527	Glossary of Alsep Terminology B6-0921-01B
528	Alsep Logistics Status Report - October
529	Operational Contingency Evaluation
530	B6-0921-05B Bx Comments on Violation of Single Point Grounding
531	B6-0921-26B - Schedule for Completion of EM Software
532	Dust Detector Design
533	Central Station Heaters and Thermistors
534	Analysis of SIDE/CCGE-Alsep Interface Circuitry
535	Alsep Transient Analysis
536	Description of SIDE/CCGE Exp. for Alsep
537	Solar Wind Exp Test Plan
538	Crew Mockup Availability and Mission and Crew Engineering Test Schedule
539	Operations Plan Block 3
540	PCM Standards
541	Operational Contingency Diagnostic Proc
542	Lunar Surface Magnet. - Eng Model Test Plans
543	Change in Heat Flow Measurement Sequence
544	SIDE/CCGE Power Profile
545	Magnetic Cleanliness
546	Magnetic and Electric Field Cleanliness Status Report
547	Alsep System Integration Tests
548	Test Plans for Acceptance Tests at Bx on SIDE/CCGE Engrg Model
549	Status Review of Electrical Transient Study
550	Request for Waiver of Alsep EMI Spec
551	Probability of Success for Expended Alsep Operations

ALSEP TECHNICAL MEMO (Cont.)

Number	Title
552	Alsep Operational Contingency Recovery and Optimization Procedures
553	Demodulator Performance Analysis
554	Cross Talk in Screen Shielded Flat Conductor Cable
555	Radiated EMI Tests on Screen Shielded Flat Conductor
556	Alsep Maintenance Flow Diagrams
557	Alsep Compartment #1 - Stress Analysis
558	A Possible Solution to the Exp. Turn-on Transient Problem
559	Alsep Transportation & Handling Manual, Topical Outline
560	Command Decoder Reliability Consideration
561	Reduction of Thermal Barrier Heat Leak
562	Measuring Devices, Distance, Leveling, Alignment
563	Alsep Logistics Status Report, Nov. 1966
564	Thermal Analysis of Alsep ASE Mortar Box
565	Packing & Shipping Requirements for the Alsep Program
566	Not Applicable
567	PDU & Timer Reliability Design Change Status
568	Guidelines for the Use of Beryllium on Alsep Passive Seismometer
569	Data Processor Reliability Considerations
570	Results of Detailed Thermal Analysis of Dust Detector
571	Parts Application Analysis
572	Alsep RFI System Test
573	Word Format for Heat Flow Experiment
574	Experiment Interface Monitoring in the System Test Set
575	Final Report - Human Factors Evaluation Geophone Design for ASE
576	Experiment Sequence Information
577	Solar Wind Programming for DPS 2000 (System Test Set)
578	Not Applicable
579	ASE (B6-1114-07B) Thumper Test Plan
580	Magnetometer Programming for DPS 2000 (System Test Set)
581	Passive Seismometer Programming for DPS 2000 (System Test Set)
582	SIDE/CCGE Programming for DPS 2000 System Test Set
583	Data S/S Programming for DPS 2000 System Test Set
584	Fuel Cask Mount Loads
585	Shield Test Requirements Fuel Cask Thermal

ALSEP TECHNICAL MEMO (Cont.)

Number	Title
586	DPS 2000 (System Test Set) Programming 100 more simultaneously operating experiments
587	Nov. Engineering Model Test Progress Report (30 Nov. 66)
588	Test Procedure for SW Experiment - Engineering Model
589	Telemetry Calibration Data Book
590	Single Failure Points
591	Power Demands of the Alsep Magnetometer
592	30 mc Operation of ASE-RF Link B6-1114-01B
593	Sun Compass Design Requirements & Leveling Limitations
594	Alsep Integrated System Tests - Acceptance Criteria
595	Preliminary Thermal Analysis of the Heat Flow Probe Electronics
596	Alsep Logistics Status Report, Dec. 19, 1966
597	Noise Immunity Tests - SW Spectrometer
598	Justification for Modifying the Lunar Surface Model
599	Materials Applications in Alsep
600	Magnetic Survey Test Report
601	Not Applicable
602	Quality Program Performance Audit
603	Active Seismic Grenade Antenna Study
604	Dec. Engineering Model Test Progress Report (31 Dec. 1966)
605	Failure Rate Data for Alsep
606	Magnet Wire Characteristics
607	Thumper Cable Deployment
608	ASE Thumper Test Results
609	Parts Application Analysis - Command Decoder
610	Parts Application Analysis - Power Conditioning Unit
611	Parts Application Analysis - Power Distribution Unit
612	Qualification Status List - Data S/S
613	Alsep Logistics Status Report - Jan. 1967
614	Alternate Experiment Arrays for Alsep
615	Over Sensitive Fairchild 9042 Gates
616	Test Procedure for LSM Engineering Model
617	Dust Detector Engineering Model Development and Tests

ALSEP TECHNICAL MEMO (Cont.)

Number	Title
618	Jan. Engineering Model Test Progress Report
619	Heat Flow Experiment Engineering Model 1 & 2 Testing Sequence
620	Summary Reliability Assessment Report
621	Impact of New Lunar Surface Information on Alsep Design
622	Alsep EMI Tests on the RTG
623	SIDE Test Results of the Electronics Breadboard
624	Qualification Status List Power S/S
625	Evaluation of Alsep Components at 1/6 Gravity
626	Feb. Engineering Model Test Progress Report
627	Feasibility of Installation of ALSD into Alsep w/LM/Alsep in SLA
628 (missing)	Alsep Logistics Status Report - February
629	Alsep Support Material List
630	Test Procedure CPLEE Engr. Model
631	Design Info. on RF Antenna Cap for Alsep Central Station Testing
632	RTG Temp. Measurement Error Analysis & Design
633	LSM Engrg. Model Pre-Integration Test Results
634	ASE Overall Test Plan
635	Alsep Grenade Launch Assy Test Set Manual; Topical Outline
636	Parts Application Analysis ASE
637	Alsep Flight A-1 Model Test Program
638	Evaluation of Heat Flow Probe Box at 1 Gravity
639	4 Proposed Flight Arrays - Engineering Assessment of System
640	Supplement to ASE Overall Test Plan
641	CPLEE DPS 2000 (System Tests)
642	HF Programming for DPS 2000 (STS)
643	March Alsep Engineering Model Test Report
644	Experiment Ripple-Off circuitry Description & Analysis
645	Design Verification Test Procedure PSE S/S Model EM-3
646	Alsep Telemetry Data Simulation
647	Thermal Shroud Storing & Handling Procedure
648	Brief Description of PSE Sensor Exciter
649	Not Applicable
650 (missing)	Incoding of Discrete Measurements

ALSEP TECHNICAL MEMO (Cont.)

Number	Title
651	Alsep EMT Test Plan Reschedule
652	ASE Geophonic & Mortar Box Assy Alignment Tests
653	ASE Grenade Thrust Analysis
654	ASE Grenade Performance Analysis Lunar vs. Earth Operation
655	ASE Impact of Alternate Thumper Cable Configuration or Deployment
656	Telemetry Formats for Flights 1, 2, 3, & 4
657	Prototype Experiment Pre-Integration, Integration & Crosstalk Test Results
658	Alsep Link Performance vs. Antenna Pointing Error
659	LSPE Int. Test Plan - ATM 928 Response to CDR RFC 07-22 ASE Redundant Antenna Study
660	Shield Extension to Protect Astronaut from GE Fuel Cask
661	April Engr. Model Test Progress Report
662	ASE Accuracy of Velocity Measurement
663	Results of Passive Seismic Experiment Deployment Tests
664	Dynamic Analysis of Comp. #1-LTA-3
665	System Test Set Magnetic Tape Usage
666	Prototype Central Station Model G
667	Bx Magnetic Test Facility
668	Results of CPLEE Engrg. Model Tests
669	Qualification Status List - ASE (Cancelled - replaced by 624B)
670	Evaluation of SW Spectrometer Exp.
671	Static & Dynamic Test Results - Comp. #1
672	Evaluation of Data S/S Failure Modes.
673	Experiment Marking Requirements
674	Not applicable
675	The Effect of Changes in Reserve Power on Central Station Thermal
676	Support Leg to Lift the LSM from Pallet No. 1 Evaluation of Lunar Control
677	Qual to Jumper Cable Status List - Assy, Flat Cable
678	Evaluation of the Charged Particle Lunar Environment Experiment

ALSEP TECHNICAL MEMO (Cont.)

Number	Title
679	Evaluation of the Boom Removal from LM Concept for Alsep
680	Thumper Design Evaluation Test
681	Revised EMI Test Program
682	Thermal Analysis of the ASE
683	Comments on Alsep 1 SN Command Sequence
684	Aiming Evaluation of the CPLEE Leg Design & Mechanism
685	Evaluation of Design Alternatives
686	Prototype Experiment Test Results - May/June 1967
687	Not applicable
688	Expt. Designers Guide for new Alsep Experiments
689	Effects of the LM on Alsep
690	Visibility Test of Alternate Conceptual Designs for Alsep Solar Cell Color System
691	Graphite Cask
692	Preliminary Test of the Heat Flow Probe Deployment
693	Results of Shirt Sleeve Test on Aided First Removal of Alsep - Using a shortened boom
694	Data Subsystem Trans Support Requirements
695	Results of Feasibility Test Perform to Determine Handling Aspects of Isotope Heater Decoupling Concepts for Alsep Solar Cell Power System
696	Address Codes for Alsep
697	Alsep Solar Power Battery Thermal Control Test Plan
698	Alsep Solar Power Simulated System Test Plan
699	Under Water Lunar Gravity Simulation Feasibility Test Results
700	Post Vibration Crew Engineering Test
701	Alsep GSE/GAEC Interstallation Fixture Interface
702	Rev. EMI System Compatibility Test Requirements
703	Test & Evaluation of the Heat Flow Experiment
704	Alsep STS Software Description & Operation
705	Not applicable
268w	Mass Properties Alsep Systems
706	Qualification Status List Assembly Flat Cables
707	Alsep Solar Power Study

ALSEP TECHNICAL MEMO (Cont.)

Number	Title
708	Results CPLEE Alignment & Devices Test (See ATM 684)
709	Results of Feasibility Test of Battery Mounting Interconnecting Solar Cell Power System
710	Alsep Solar Power Study
711	Parts Application Analysis Data Transmitter
712	Parts Application Analysis Command Receiver
713	Summary & Status of Alsep Central Station Thermal Control Design
714	Preliminary Design Considerations for Direct Radiotone Thermal (DRT) Control
715	Alsep Solar Power Study
716	Crew Engr. Test for Handling of the Active Seismic Exp. During Deployment
717A	Active Seismic Exp. Overall Test Plan - Rev A
718	Alsep Fasteners Studies
719	Prototype Thermal Vacuum & STS Software Limits and Danger Limits
720	Alsep Solar Power Study Status Report
721	Thermal Vacuum Contingency Plan
722	Alsep Mission Operational & Task Sequence Description Flight (3)
723	ASE-GLA Antenna Stowage
724	ASE-Thumper Weight Reduction
725	Alsep Cask Support Design Review CCP #29
726	Alsep Battery Test Report
727	Simulated System Test Alsep Solar Power Project
728	Alsep Proto A Vibration Tests & Subsystem Test Specs.
729	Prototype A Thermal Vacuum Test Summary
730	Results of Solar Cell Power System Panel Deployment Test - Final Report
731	Alsep Solar Power Study
732	See ATM 752
733B	Qualification Test Instrumentation Requirements
734	Qualification Status List Command Receiver
735	Qualification Status List Data Transmitter
736	Alsep Multiple Fastener Release System

ALSEP TECHNICAL MEMO (Cont.)

Number	Title
737	Proto A Alsep Central Station Thermal Analysis
738	Not applicable
739	Alsep Design Reference Task Sequence
740	Central Station Power Switching Characteristics
741	Heat Loss through LSM Flight Cable
742	Word 33 Limits for Flight 1 & 2 Qual Model
743	Failure Investigation Multiple Grenade Launching
744	Alsep Proto A Vibration Test Part II
745	Preliminary Design Considerations for On-Pad Testing Analysis
746	Human Visual Performance during Deployment of Alsep & Lunar Visual Environment
747	EMI Review
748	Equipment Constraints on Alsep Deployment Sequence
749	Alsep Automatic Switchable Hood Study Final Report
750	Justification of Use of Proto Primary Pullet of Thermal Vacuum Testing of S/P 2 Qual Model
751	Thermal Analysis of Alsep Proto A Central Station with Comparison to Test Results
752	Proto A Thermal Vacuum Test Summary
753	Results of the Thermal Mapping Test on the Alsep PCU
754	Boyd Bolts Installation and Inspection (missing)
755	Not applicable
756	Rationale for Crosstalk Test Procedure 2333060
757	Thermal Support of Alsep Central Station using Reserve Power
758	Test Plan for EMI Testing of ASE Electro Explosive Devices
759	Alsep Fuel Cask & Support Structure Proto (0-1) Vibration Test Evaluation
760	Alsep Fuel Cask Mount Design Review Meeting
761	Central Station - Timer & Command Decoder Interface

ALSEP TECHNICAL MEMO (Cont.)

Number	Title
762	ALSEP Implacment Study
763	ALSEP Engr. Graphite Cask Cooling Test (April 1968)
764	ALSEP Proto Cask Cooling Test
765	QSL for ALSEP Flight 1
766	QSL S/P #1
767	QSL Antenna Assy
768	QSL Diplexer Switch & Filter Assy
769	QSL Command Decoder Assy
770	QSL Data Processor & 90 Channel Multiplexer/Converter Assy
771	QSL Power Dist. Unit Assy
772	Not Used
773	QSL PSE
774	QSL SWE
775	QSL Magneto Exp.
776	QSL S/P #2
777	QSL SIDE/CCGE
778	QSL RTG Assy
779	Cancelled
780	Qual Status List - Fuel Cask Assy.
781	Tarnished Collector Pins - 90 Channel Multiplexer
782	Never Issued
783	Development of a PCU Power Dissipation Model
784	Magnetic Facility Calibration
785	ALSEP Qual SA Model Qualification Test Plan
786	ALSEP Flight System No. 1 Acceptance Test Plan
787	ALSEP Flight System No. 2 Acceptance Test Plan
788	ALSEP Qual B Model Qualification Test Plan
789	ALSEP Qual C Model Qualification Test Plan
790	ALSEP Flight System No. 3 Acceptance Test Plan
791	ALSEP Flight System No. 4 Acceptance Test Plan
792	Final Report - Fastener Reduction Vibration Test Program for ALSEP Array A
793	Temperature Sensor Calibration Results - Central Station Sensors
794	ALHT Support Pin Design Analysis

ALSEP TECHNICAL MEMO (Cont.)

Number	Title
795	ALSEP Central Station Specular Enclosure Test Report
796	ALSEP Prototype A Central Station Final Thermal Analysis and Test Results
797	Analysis of Reserve Power Telemetered Data for QSA Post-Vibration IST
798	CPLEE Parts Application Analysis
799	Calibration Curves and Calibration Tapes
800	Investigation of Flight II Central Station Overvoltage Condition
801	Fairchild UA 702 and UA 709 Operational Amplifiers Parametric Stability versus Overvoltage
802	Flight Off-Loading Qual Confidence Program for Array A ALSEP Subpackage I
803	ALSEP Configuration A Two Man Deployment Task Sequence
804	ALSEP Configuration B Two Man Deployment Task Sequence
805	ALSEP Configuration C Two Man Deployment Task Sequence
806	Flatpack Reliability Tests
807	Final Report ALSEP Boydbolt Fastener Design Verification Test Program
808	Machine Plotting of the ALSEP Calibration Curves
809	ALSEP Flight 1 Test Summary Report
810	Flight 1 RF Parameters
811	Central Station Timer Starting
812	ALSEP Configuration A One-Man Deployment Task Sequence
813	ALSEP Configuration B One-Man Deployment Task Sequence
814	ALSEP Configuration C One-Man Deployment Task Sequence
815	Generator Warmup Characteristics
816	ALSEP Fasteners Reduction Study
817	CPLEE Flight Model Reliability Prediction Report
818	Reliability Evaluation Test of Babcock Latching Relay - Particle Malfunction Investigation
819	Qualification Status List Fuel Cask Instructor Assembly D-2/M-5 Models
820	Final Report Flight Off-Loading Qual Confidence Program for Array A ALSEP Subpackage #2
821	Summary of ALSEP Subpackage #2 Thermal Control Design
822	Thumper Impact Plate Verification (2338673)
823	Grenade Launch Test of the ASE Vertical Sensor Assembly

ALSEP TECHNICAL MEMO (Cont.)

Number	Title
824	ALSEP Qual S/A Thermal Vacuum Chamber Test Report
825	ALSEP Flight 3 Qual Status List
826	Flt. #3 HFE Transient Test
827	Calibration Data Program
828	Reliability Evaluation of Bulova Accutron Timers
829	ASE Qualification Test
830	MSFN Command Anomaly Resolution
831	ALSEP Flight #1 Central Station S-13G Thermal Coating Adhesion Investigation
832	ALSEP Qualification Design Limit Vibration Test Data Summary
833	ALSEP Communications Performance Margin Summary
834	ALSEP Cask/LM Thermal Qualification Final Test Report
835	ALSEP Cask Assy Gearbox T/V Test
836	
837	HFE/S/N-05 Calibration Constants
838	Cancelled
839	Guidelines for Modified ALSEP Design Study
840	FEMCA of ASE EMI Modification
841	Parts Application Analysis S-Band Transmitter
842	Modified ALSEP Maximum Antenna Pointing Error
843	Investigation of ALSEP Address Codes
844	ALSEP Cask Cooling Performance Summary
845	Teledyn 421 Relay Usage in Solid State Trainer (RSST)
846	RSST/Lunar Day Counter Reliability Analysis
847	Alignment of ALSEP at Latitudes off the Lunar Equator
848	Established Reliability Parts-Drawing Callout and Usage
849	Resettable Solid State Timer (RSST) Command Decoder Interface
850	PSEP Qual, Flight Acceptance and Qual Re-test T/V Chamber Test Report
851	ALSEP Thermal Performance at Off-Equator Latitudes
852	Failure Modes & Effects Analysis, Fuel Handling Tool, & Fuel Capsule/Cask Assembly Interface
853	Command Decoder Failure Mode, Effects and Criticality Analysis

ALSEP TECHNICAL MEMO (Cont.)

Number	Title
854	Data Transmitter
855	Failure Modes and Effects Analysis, Fuel Handling Tool, and Fuel Capsule/Cask Assembly Interface
856	A-2 ALSEP Data Transmitter Reliability Prediction
857	A-2 ALSEP Mode Effects & Criticality Analysis (System level)
858	Crew Engineering ASE Test
859	ALSEP Qual Status List, Flight 4
860	Parts Application Analysis Dual 90 Channel Multiplexer
861	ALSEP S-Band Data Transmitter Short Term Stability
862	ALSEP Flight 1 PSE Thermal Anomaly Study
863	Dual 90 Channel Mux Reliability Prediction & Failure Mode, Effects and Criticality Analysis
864	ASE Off-Equatorial Thermal Study
865	Magnetic Cleanliness Guidelines
866	
867	Apollo 14 LRRR Qualification Status List
868	Failure Modes & Effects Analysis LRRR
869	A. D. Little LRRR Contractor Parts List
870	Apollo 14 LRRR Pointing Analysis
871	Apollo 14 LRRR Structural Analysis
872	Command List (Array D)
873	Calculation of Failure Rate of Transistors of Operating within the PSE Center of the Lunar Surface
874	LRRR Task Sequence/Timeline for Littrow Landing Site
875	LRRR Emplacement Range & Azimuth from LM
876	Evaluation of Flight 14 LRRR Mock-up Design
877	Crew Engineering Design Effort for LRRR
878	RSST Failure Modes & Criticality Analysis
879	RSST Parts Applications Analysis
880	RSST Single Point Failure Modes Summary
881	RSST Math Models, Block Diagrams and Predictions
882	Redundant ALSEP Uplink System Final Report
883	Crew Systems Analysis Report for LRRR
884	Human Factors Analysis Effort for LRRR
885	Flat Conductor Cable Folding Tests
886	LRRR Astronaut Trainer Acceptance Test Results

ALSEP TECHNICAL MEMO (Cont.)

Number	Title
887	PSE Thermal Anomaly Study
888	LRRR Task Sequence/Time line for Framauro Landing Site
889	ELLSEP System Design Trade-off (CCP-247)
890	LRRR Emplacement Range 4 Azimuth from LM for Fra Mauro Landing Site
891	RSST C/S Compatibility Testing
892	Investigations into ALSEP Flight 1 - A Transmitter Anomaly
893	Final Report - ALSEP Dust Protection Study
894	Array D - Failure Modes & Criticality Effects for Structural Thermal Subsystem
895	Bi-Reflector HFE Electronics Package Thermal Design
896	Thermal Design of CPLEE
897	Transmitter Design Analysis
898	Reliability Analysis of PSE Sensor Heater Modification
899	Apollo 14 LRRR Final Thermal Analysis
900	HFE Subpallet Dynamic Analysis
901	Command List for Array A-2
902	Apollo LRRR Pointing Analysis - Fra Mauro Site
903	Incorporation of HFE on Array A-2 Data Processor A/D Converter
904	Data Processor A/D Converter Parts Application Analysis
905	Failure Mode, Effect & Criticality Analysis
906	ALSEP Flight System 5 System Level Failure Mode Effects & Criticality Analysis
907	Results of Feasibility I Tests Performed to Determine Handling & Mating Aspects of HFE - Astronaut Connector
908	Analysis of No. 1 Rocket Motor Firing on ALSEP
909	ALSEP Array A-2H Layout
910	PSEP Flight Thermal Performance & Thermal Anomaly Investigation Summary
911	Parts Application Analysis ASE 16 Channel Multiplexer-A/D Converter
912	ASE 16 Channel Multiplexer-A/D Converter Reliability Prediction & Failure Mode Effects & Criticality Analysis

ALSEP TECHNICAL MEMO (Cont.)

Number	Title
913	Summary of Array E System Study
914	Alternative Deployment Schedules for the LSPE Geophones
915	Bendix Data Transmitter Qual Units
916	Analysis of LPTTL its Capabilities & Deficiencies when used with itself or an interface with LPDTL
917	Bendix Data Transmitter Housing Material Change
918	ALSEP A-2/SP-3 Structural Dynamics Analysis
919	System Level Non Carona Verification Test
920	Analysis of Pressure Data Relating to the PSE S/N 03 Pneumatic Caging Subsystem Non Conformance Status
921	Lunar Mass Spectrometer Reliability Logic Diagram
922	UniReflector HFE Electronics Package Thermal Design & Performance
923	Apollo 14 Contingency Plan
924	Apollo 15 A. D. Little LRRR Contractor Parts List
925	Apollo 15 LRRR Qualification Status List
926	Failure Modes & Effects Analysis 300 Array LRRR
927	Lunar Seismic Profiling Experiment Analysis
928	LSPE Integrated Test Plan
929	Single Point Failure Analysis Summary
930	Command List (Array E)
931	LRRR 300 Thermal Design Final Report
932	LRRR 300 Task Sequence/Time Line for Hadley Rille Landing Site
933	Apollo 15 LRRR 300 Pointing Analysis
934	Structural Analysis Report LRRR 300
935	System Safety Program Plan for ALSEP Array E
936	LRRR 300 Corner Array Dynamic Analysis
937	Preliminary LSG Numerical Reliability Analysis
938	Crew Engineering Evaluation 300 Corner LR ³ , Concept Model
939	Apollo 15 ALSEP/A-2 Deployment Procedure
940	Crew Engineering Analysis Report for LRRR (300)
941	Human Factors Analysis Effort for LRRR (300)
942	Crew Engineering Design Effort for LRRR (300)
943	LRRR (300) Astronaut Trainer Acceptance Plan
944	LRRR (300) Acceptance Test Deployment Sequence
945	LRRR (300) Astronaut Trainer Acceptance Test Results

ALSEP TECHNICAL MEMO (Cont.)

Number	Title
946	LRRR (300) Emplacement Range & Azimuth from LM
947	Array E Power Conditioning Unit Automatic Power Management Circuit
948	Deletion of Geophone Temperature Sensor
949	Array E Command Decoder Failure Mode Effects & Criticality Analysis
950	Array E Data Processor Failure Mode Effects & Criticality Analysis
951	Array E PDU Failure Mode Effects & Criticality Analysis
952	Array E PCU Failure Mode Effects & Criticality Analysis
953	Array E Central Station Failure Mode Effects & Criticality Analysis
954	Array E Command Decoder Parts Application Analysis
955	Array E Data Processor Parts Application Analysis
956	Array E PDU Parts Application Analysis
957	Array E PCU Parts Application Analysis
958	Command Decoder for ALSEP Array E
959	First Crew Engineering Evaluation of Array E - LSPE Geophone Cable Reel
960	Crew Engineering Evaluation of Array E - LMS Experiment Crew Engineering Model
961	Effect of North and South Hadley Rille Landing Sites on ALSEP A-2 Thermal Performance
962	Array E System Grounding Philosophy
963	Central Station Subsystem Description for ALSEP Array E
964	ALSEP Array E Component Non-Operating Vibration Specifications
965	LMS Reliability - Reliability Prediction
966	LMS Reliability - Parts Application Analysis
967	LMS Reliability - EEE Part List for UTD and Bendix
968	LMS Reliability - Non Metallic Material List
969	LMS Reliability - Time/Cycle Sensative Part List
970	LMS Reliability - FMECA & Single Point Failure Summary
971	Crosstalk & Ground Differentials in the Central Station
972	Safe-Arm Slide Ejection Effect on Grenade Trajectory
973	Space Suited Crew Engineering Evaluation of the Proposed Array A-2 PSE Decoupled Shroud (Crew Engineering Mockup)

ALSEP TECHNICAL MEMO (Cont.)

Number	Title
974	ALSEP Command Decoder Preliminary Functions Description
975	LSPE Parts Application Analysis
976	LSPE Failure Modes, Effect Analysis
977	LEAM Failure Mode Effect & Criticality Analysis
978	LEAM Reliability Prediction
979	Preliminary Parts Application Analysis LSGE
980	A Trade-Off Study of Various Methods of Releasing the LEAM Dust Covers
981	Reliability Prediction - Array E Redundant Command Receiver
982	Single Point Failure Summary - Array E Redundant Command Receiver
983	Parts Application Analysis - Array E Redundant Command Receiver
984	Failure Mode Effects & Criticality Analysis - Array E Redundant Command Receiver.
985	ALSEP Array E Command Decoder Breadboard Test Report
986	ALSEP Qualification Status List (QSL) Package A-2 Config. (Apollo 15)
987	PSE Decoupled Shroud Qual Status List (Apollo 15, 16 & Spare)
988	ALSEP Array E Multilayer Printed Circuit Source Qual Test Plan
989	Array E Subpackage 1 Dynamic Analysis
990	Array E LEAM Digital Interface - 54L versus Amelco Logic
991	Noisey Data Investigation, ALSEP 4
992	Expected SIDE Vibration Environment on Array A-2
993	Array D S/P 1 & 2 Vibration Test Results
994	Anomalous signal strength from ALSEP 4
995	LEAM Film Development Test Report
996	Crew Engineering Evaluation of the Array E LEAM Exper. - Crew Engineering Model
997	Apollo 14 DRT Installation Anomaly Study
998	ALSEP Array E Parts Application Analysis of Signal Con- ditioning Circuits
999	ALSEP Array E Signal Conditioning Circuits Reliability & Failure Mode Effects Critical Analysis

ALSEP TECHNICAL MEMO (Cont.)

Number	Title
1000	PSE Sensor Assembly Qualification Status List Apollo 15
1001	PSE Anomalies ALSEP 4
1002	LSPE Explosive Package Stowage Thermal Constraints
1003	ALSEP Array A-2 Contingency Procedures
1004	EMI Investigation for Array E
1005	(Failure Modes Effects & Criticality Analysis) ALSEP Array E PSK Transmitter - FMECA
1006	ALSEP Array E PSK Transmitter - Parts Application Analysis
1007	ALSEP Configuration D Two-Man Deployment Task Sequence
1008	LSG Reliability Mathematical Model Reliability Numerical Analysis & FMECA
1009	LSG CDR Parts Application Analysis
1010	LEAM Film Development Report
1011	LEAM Film Vibration Report
1012	LEAM Mechanical Tests
1013	LEAM Reliability Numerical Analysis, Reliability Mathematical Model Failure Modes, Effects and Criticality Analysis & Single Point Failures
1014	LEAM CDR Parts Application Analysis
1015	Array E Uplink Redundancy Method Justification
1016	Gross Hazard Analysis Report - LEAM Experiment
1017	Gross Hazard Analysis Report - LSG Experiment
1018	Gross Hazard Analysis Report - LMS Experiment
1019	LEAM DVT Thermal Test Report
1020	LMS Mechanical Test Reports
1021	Updated Apollo 15 LRRR 300 Corner Pointing Analysis for Hadley Rille
1022	LEAM Dynamics Analysis (DVT)
1023	Array E Time/Cycle Sensitive List
1024	Time Sensitive Cycle Items - LSG
1025	Time Sensitive Cycle Items - LEAM
1026	Parts & Materials List for LSG Experiment
1027	Parts & Materials List for LEAM Experiment
1028	Crew Engineering Test Plan for Evaluation of Array E Antenna Aiming Mechanism

ALSEP TECHNICAL MEMO (Cont.)

Number	Title
1029	LMS Thermal Vacuum Tests Reports
1030	LEAM Reliability Numerical Analysis
1031	ALSEP Array E Antenna Aiming Mechanism Design Verification Test Results
1032	Theoretical Modeling & Analysis of PCU/PDU Output Voltages
1033	ALSEP "EEE" Composite Parts List
1034	System Safety Progress Report ALSEP Array E
1035	LSPE Timer Control Module Seal Analysis
1036	LSPE Transmitting Antenna Stability Investigation
1037	Schjeldahl Dale Connectors
1038	LSP Timer Overbanking on the Lunar Surface
1039	"EEE" Parts List for LSPE
1040	Non-Metalic Materials List for LSPE
1041	Time/Cycle Sensitive Components List for LSPE
1042	LMS Structural Analysis Report
1043	EEE Parts List for LSG
1044	Non-Metalic Materials List for LSG Experiment
1045	ALSEP Composite Non-Metalic Materials List
1046	LSP Explosive Package Fragmentation Study
1047	Crew Engineering Evaluation of Array D MPS Pallet Crew Eng. Model
1048	July System Safety Progress Report - ALSEP Array E
1049	LSP Detailed System Hazard Analysis
1050	ALSEP/LCRU EMC Test Results
1051	Crew Engineering Evaluation of Array E Antenna Aiming Mechanism Engineering Model
1052	ALSEP Qualification Status List Array D Configuration
1053	LSP Operational Hazard Analysis
1054	Monthly Array E Qualification versus Flight System Differences Report
1055	A-2 HFE DH15 Anomaly Investigation
1056	LSP Ground Operations and Safety Plan
1057	LSG Boydbolt Release Tests Report
1058	LSG Flight Sensor Closed Loop Performance Computer Analysis.

ALSEP TECHNICAL MEMO (Cont.)

Number	Title
1059	Results of A-2 Connector "Green Crud" Investigation
1060	Apollo 15 Anomalies Report
1061	Plating of PSE Leveling Stool
1062	Apollo 15 PSE Anomalies
1063	Aug. & Sept. Safety Progress Report ALSEP Array E
1064	ASE Redesign Evaluation
1065	Structural Analysis Report LEAM
1066	LEAM Dynamic Analysis Flight Model
1067	October System Safety Progress Report ALSEP Array E
1068	HFE Power OFF During Lunar Night
1069	ALSEP Array E Software Description & Operation
1070	Apollo 14 PSE Long Period Oscillation
1071	Array E ALSEP LMS High Voltage Power Supply Capacitor Problem Analysis and Corrective Action
1072	Array E System Description
1073	ALSEP Configuration E 2 Man Deployment Task Sequence
1074	ASE Grenade Transmitter Frequency Drift
1075	LEAM Thermal Design Report
1076	ALSEP Array E Power Budget
1077	ALSEP Contingency Procedures for Apollo 16
1078	November System Safety Progress Report ALSEP Array E
1079	LSPE Explosive Package Fragmentation and Cratering Related to Striking Probability Investigation
1080	LSPE Interim Stowage Thermal Constraints
1081	TTL-54L
1082	Recommendations for Minimizing Green Crud
1083	ALSEP Array E Engineering Model S/P 1 with PSE - Design Limit Vibration Test Results
1084	Dec. -Jan. System Safety Progress Report, Array E
1085	ALSEP Array E Design Verification Model Test Report
1086	LSPE Thermal Battery Test
1087	Investigation into the Scrambling of Array E Qual Model PDU Relays at Turn-On
1088	LSPE Safe Arm Slide Failure Evaluation Report
1089	Feb. -March System Safety Progress Report Array E
1090	ALSEP Array E Engineering Model SP-2 Design Limit Vib. Test Results

ALSEP TECHNICAL MEMO (Cont.)

Number	Title
1091	ALSEP Array E Engineering Model SP-1 with LSG - Design Limit Vibration Test Results
1092	SEP/ALSEP EMI Interface
1093	Array E S-Band Compatibility Test Results Analysis
1094	LSPE Housing & Charge Assembly Foam Test Report
1095	Array E Calibration Curves
1096	Spurious Status Changes in Array E
1097	Lunar Mass Spectrometer Design Verification T/V Test
1098	Array E Action Item 604 - Ripple on +5 volt line
1099	Preliminary Test Evaluation on LSPE Hazard Analysis
1100	Investigation of Array E Exper. EMI Test Data Validity
1101	April System Safety Progress Report Array E
1102	ALSEP Contingency Procedures for Apollo 17
1103	Handling, Packaging, Transportation & Storage of ALSEP Array E Flight Hardware & Support Equipment
1104	Comparative Safety Analysis LSP Timers
1105	EMI Test Results & Margin of Compatibility for ALSEP Array E
1106	System Level Qual Status List Array E
1107	System Analysis of 2 yr life capability
1108	Thermistors used as linearized temperature sensors
1109	Lunar Seismic Profiling Exper. Design Verification Thermal/Vacuum Test
1110	LSPE Qualification & Flight Acceptance T/V Test Summary & Therm Design Final Report
1111	LMS Qualification & Flight Acceptance Thermal/Vacuum Test Summary & Thermal Design Final Report
1112	Array E ALSEP Qual/Flt Deferences & Rationale
1113	ALSEP Array E C/S Thermal Design/Analysis/Test Final Report
1114	Crew/Mission Operational Hazard Analysis
1115	LSP Final Safety Report
1116	ALSEP Array E LSG Thermal Control Design Analysis & Tests Final Report
1117	ALSEP Array E Heat Flow Experiment Thermal Design Analysis Test Final Report

ALSEP TECHNICAL MEMO (Cont.)

Number	Title
1118	LEAM Thermal Design Analysis/Test Final Report
1119	Qual SE (SP-1&2) Design Limit Vibration Test Results
1120	LEAM Thermal Anomaly Investigation Report

APPENDIX B

LIST OF
ALSEP TEST REPORTS

(ATR)

ALSEP TECHNICAL REPORTS

<u>ATR/BSR No.</u>	<u>Title</u>
1	ALSEP Mission Requirements
2	ALSEP System Reliability Requirements
3	ALSEP Reliability Task Definition
3A	ALSEP Reliability Task Definition
4	ALSEP System Requirements and Constraints
5	Experiment Evaluation
6	Heat Flow Exp. BxA Probe Concept
7	Configuration Mgmt. Goals and Constraints
8	Configuration Mgmt. Rpt. Performance Parameters
9	Configuration Mgmt. Rpt. Dimensional Data
10	Preliminary Specification Data Subsystem
11	Preliminary Spec. Ground Support Equipment
12	Preliminary Power Generation Conditioning Subsystem
13	Thermal Coating Evaluation
14	ALSEP Test Program
15	ALSEP HFE Conceptual Design Study
16/1374	ALSEP Dynamics Analysis Report
17/1451	Block III System Definition Handbook
18/1442	Operations Analysis Block II Operations Plan
19/1466	Command & Telemetry Effectiveness Evaluation

ATR/BSR No.Title

20/1467	Block IV Operations Plan
21/1490	(CANCELLED)
22/1494	Feasibility Study Fuel Cask Release & Separation Mech.
23/2277	Feasibility Study
24/2291	Thermal/Vacuum Test Report, ALSEP Proto A System Deployed
25/2295	Preliminary Integrated Systems Test Report (TP2333034)
26/2299	Preliminary Central Station Pwr. Dissipation (TP2337925)
27/2300	Preliminary System EMI (TP2333087)
28/2308	Preliminary Report on Qual SA ALSEP System Stray Field Magnetic Properties Test (TP2338187)
29/2311	Preliminary Qual SA Crosstalk Test Report
30/2312	Final Report Vibration Accep. Test on ALSEP Sub Package #1 Assy
31/2318	Block V Operations Plan
32/2319	Active Seismic Exp. NASA White Sands Test Facility Test Report
33/2320	Final Test Report for CM2
34/2321	Preliminary Vibration Environment Acceptance Test Report on Sub Pkg. II Assy (TP2337941)
35/2322	Preliminary Vibration Environment Acceptance Test Report on Sub Pkg. I (TP2337940)
36/2325	Preliminary Qual Model SA Integrated System Test Post Vibration
37/2326	ALSEP Qual Model SA Sub Pkg I Assy Mass Properties Determination

ATR/BSR No.Title

38/2331	Report on Emergency Situation ALSEP Qual Model T/V Test
39/2327	Final Test Report-Stray Field Magnetic Properties Acceptance Test on (ALSEP Qual Model SA)
40/2328	Final Test Report - Vibration Environment Acceptance Test on Sub Pkg II Assy (ALSEP Qual Model SA)
41/2329	Final Test Report - ALSEP System Crosstalk Acceptance Test (ALSEP Qual Model SA)
42/2330	Final Test Report Mass Properties Determination Acceptance Test on Sub Pkg I Assy (ALSEP Qual Model SA)
43/2337	Central Station Power Dissipation Final Acceptance Test Report Qual Model SA
44/2340	Preliminary Test Report Integrated Status Test on ALSEP System (ALSEP Flight Model #1)
45/2341	Preliminary Test Report-EM2 Test on ALSEP System (ALSEP Flight Model #1)
46/2342	Preliminary Test Report-Central Station Power Dissipation Test (ALSEP Flight Model #1)
47/2343	Preliminary Test Report-Stray Field Magnetic Properties Test on ALSEP System (ALSEP Flight Model #1)
48/2344	Final Test Report Qual Model SA IST (1)
49/2345	Final Test Report Qual Model SA IST (2)
50/2348	Preliminary Test Report-Flight 1 LSM Integration & IST
51/2355	Preliminary Test Report-Flight 1 S/P1 Mass Properties
52/2350	Final Test Report-Qual Model SA Therm Vacuum Acceptance
53/2351	Final Test Report-Flt #1 C/S Power Dissipation
54/2352	Final Test Report-Flt #1 Ambient IST

ATR/BSR No.Title

55/2353	Final Test Report-Flt #1 System EMI
56/2354	Final Test Report-Flight #1 Magnetic Properties
57/2362	Final Test Report-Flt #1 Mass Properties Sub Pkg #1
58/2349	Preliminary Test Report-Qual SA Magnetic Properties Stowed #1
59/2366	Preliminary Test Report-Qual SA Mass Properties S/P #2
60/2367	Preliminary Test Report-Qual SA Accept. Thermal Vac.
61/2368	Preliminary Test Report-Flt #1 Magnetic Properties Stowed S/P #1
62/2369	Preliminary Test Report-Flt #1 Magnetic Properties Stowed S/P #2
63/	Not Used
64/2370	Preliminary Test Report-Flts #1 & 2 Vibration Acceptance S/P #1
65/2371	Preliminary Test Report-Flt #1 Vibration Acceptance S/P #2
66/2372	Preliminary Test Report Tumble Test S/P #1
67/2373	Preliminary Test Report Tumble Test S/P #2
68/2374	Final Test Report-Qual SA Magnetic Properties Stowed S/P #1
69/2375	Final Test Report-Qual SA Mass Properties Stowed S/P #2
70/2376	Final Test Report Qual SA Acceptance Thermal/Vacuum
71/2377	Final Test Report Flt #1 Magnetic Properties S/P #1
72/2378	Final Test Report Flt #1 Magnetic Properties Stowed S/P #2
73/2379	Final Test Report Flt #1 Vibration Acceptance S/P #1

ATR/BSR No.Title

74/2380	Final Test Report-Flt #1 Vibration Acceptance S/P #2
75/2381	Final Test Report-Flt #1 Tumble Test S/P #1
76/2382	Final Test Report-Flt #1 Tumble Test S/P #2
77/2383	Final Test Report-Flt #1 Mass Properties S/P #2
78/2384	Preliminary Test Report-Qual SA Magnetic Properties Stowed S/P #2
79/2385	Final Test Report-Qual SA Magnetic Properties Stowed S/P #2
80/2390	Preliminary Test Report-Flt #1 Mass Properties S/P #2
81/2401	Preliminary Test Report-Flt #1 Acceptance Thermal Vacuum Test
82/2402	Preliminary Test Report-Qual SA Design Limit Vibration S/P #1
83/2403	Final Test Report-Qual SA Design Limit Vibration S/P #1
84/2404	Preliminary Test Report-Qual SA Design Limit Vibration S/P #2
85/2405	Final Test Report-Qual SA Design Limit Vibration S/P #2
86/2406	Preliminary Test Report-Qual SA Shock S/P #1
87/2407	Final Test Report-Qual SA Shock S/P #1
88/2408	Preliminary Test Report-Qual SA Shock S/P #2
89/2409	Final Test Report-Qual SA Shock S/P #2
90/2412	Preliminary Test Report-Qual SA Acceleration S/P #1
91/2413	Final Test Report-Qual SA Acceleration S/P #1
92/2414	Preliminary Test Report-Qual SA Acceleration S/P #2
93/2415	Final Test Report-Qual SA Acceleration S/P #2

ATR/BSR No.Title

94/2417	Preliminary Test Report-Design Limit Base Line Pre-Vibration Volt Test Report
95/2423	Preliminary Test Report-ALSEP S-Band Antenna VSWR Verif. TP 2338612
96/2424	Preliminary Test Report-ALSEP Program Pallet 2 Thermal (2338616) Acceptance Test
97/2434	Final Test Report-Modified IST Baseline Pre-Vib S/P #1
98/2435	FTR-S-Band Antenna USWR Verification Flight 1
99/2436	FTR-Pallet #2 Therm Acceptance Flight 1
100/2440	FTR-Flight #1 Acceptance Thermal/Vacuum Test 6 Volumes
101/2444	Preliminary Test Report-Simulated Mission (Qual SA)
102/2445	FTR-Simulated Mission (Qual SA)
103/2446	(CANCELLED)
104/2447	(CANCELLED)
105/2448	ALSEP Boydbolt Fastener Design Verification Test Program
106/2449	Preliminary Test Report-Mass Properties Determination S/P #1 (ALSEP Model D-2 Flight)
107/2450	Final Test Report-Mass Properties Determination S/P #1 (ALSEP Model D-2 Flight)
108/2451	Preliminary Test Report-Vibration Acceptance S/P #1 (ALSEP Model D-2) Flight
109/2452	Final Test Report-Vibration Acceptance S/P #1 (ALSEP Model D-2) Flight
110/2464	ALSEP Qual SA Test Summary Report
111/2465	Preliminary Test Report-D-2 Model (Flight) S/P #2 Mass Properties Test

ATR/BSR No.Title

112/2466	Final Test Report-D-2 Model (Flight) S/P #2 Mass Properties Test
113/2467	Preliminary Test Report-D-2 Model (Flight) S/P #2 Vibration Acceptance
114/2468	Final Test Report-D-2 Model (Flight) S/P #2 Vibration Acceptance
115/2471	Preliminary Test Report-Mass Properties Determination Acceptance Test S/P #1 (Model D-2 Spare)
116/2472	Final Test Report-Mass Properties Determination Acceptance Test S/P #1 (Model D-2 Spare)
117/2473	Preliminary Test Report-S/P #1 Vibration Acceptance Test (D-2 Spare)
118/2474	Final Test Report-S/P #1 Vibration Acceptance Test (D-2 Spare)
119/2476	Preliminary Test Report-Central Station Power Dissipation Test (ALSEP Flight #2)
120/2477	Final Test Report-Central Station Power Dissipation Test (ALSEP Flight #2)
121/2482	Final Test Report-Model D-2 Spare Vibration Acceptance S/P #2
122/2483	Final Test Report-Model D-2 Spare Mass Properties S/P #2
123/2484	Final Test Report-Model D-2 Spare Design Limit Vibration S/P #1
124/2485	Final Test Report-Model D-2 Spare Design Limit Vibration S/P #2
125/2487	Final Test Report-Flight System #2 S-Band Antenna VSWR
126/2489	Final Test Report-Flight System #2 System EMI
127/2490	Final Test Report-Flight System #2 Magnetic Properties Deployed

ATR/BSR No.Title

128/2492	Final Test Report-Flight System #2 IST - Ambient
129/2499	Final Test Report-Flight #2 Vibration Acceptance S/P #1
130/2500	Final Test Report-Flight #2 Vibration Acceptance S/P #2
131/2501	Final Test Report-Flight #2 Mass Properties S/P #1
132/2502	Final Test Report-Magnetic Properties Stowed S/P #1
133/2503	Final Test Report-Flight #2 Tumble Test S/P #1
134/2504	Final Test Report-Flight #2 Tumble Test S/P #2
135/2509	(CANCELLED)
136/2510	Final Test Report-Flight #2 Magnetic Properties S/P #2
137/2514	Final Test Report-Modified IST (Post-Design Limit Vibration)
138/2515	Final Test Report-Modified IST (Post-Acceleration)
139/2516	Final Test Report-Modified IST (Post-Shock)
140/2521	Final Test Report-Pallet #2 Thermal Acceptance
141/2522	Final Test Report-S-Band Antenna VSWR (Post-T/V)
142/2523	(CANCELLED)
143/2524	Final Test Report-Flight #1 IST (Recalibration)
144/2540	Final Test Report-S-Band Helical Antenna VSWR Verification Test, Flight System #3
145/2542	Final Test Report-Mass Properties S/P #2 Flight #2
146/2543	Final Test Report-Thermal/Vacuum Acceptance Flight #2
147/2544	Final Test Report-Central Station Power Dissipation Flight #3
148/2545	Final Test Report-IST (Ambient)Qual SB

ATR/BSR No.Title

149/2546	Final Test Report-Design Limit Vibration (S/P #1) Qual SB
150/2547	Final Test Report-Design Limit Vibration (S/P #2) Qual SB
151/2548	Final Test Report-Mass Properties (S/P #2)Qual SB
152/2557	Final Test Report-Flight System #3 System EMI
153/2588	Final Test Report-Flight System #3 IST (Ambient)
154/2561	Final Test Report-Flight #3 Mass Properties S/P #1
155/2562	Final Test Report-Flight #3 Mass Properties S/P #2
156/2563	Final Test Report-Flight #3 Vibration Acceptance S/P #1
157/2564	Final Test Report-Flight #3 Tumble Test S/P #1
158/2567	Final Test Report-Flight #3 Vibration Acceptance S/P #2
159/2568	Final Test Report-Flight #3 Tumble Test S/P #2
160/2570	Final Test Report-Qual SB Design Limit T/V
161/2571	Final Test Report-Qual SB Design Limit Shock S/P #1
162/2572	Final Test Report-Qual SB Design Limit Shock S/P #2
163/2573	Final Test Report-Qual SB Modified IST (Post Shock)
164/2574	Final Test Report-Qual SB Design Limit Acceleration (S/P #1)
165/2575	Final Test Report-Qual SB Design Limit Acceleration (S/P #2)
166/2576	Final Test Report-Qual SB Mass Properties (S/P #1)
167/2577	Final Test Report-Qual SB IST (Ambient)-Post Thermal & Mechanical Test
168/2584	Final Test Report-Flight #3 Pallet #2 Thermal Acceptance
169/2585	Final Test Report-Flight #3 Design Limit Thermal Vacuum
170/2586	Final Test Report-Flight #3 VSWR (Post T/V)

ATR/BSR No.Title

171/2587	Final Test Report-Baseline Functional Tests
172/2588	Final Test Report-Design Limit T/V (ASE P/A, Mortar Firing, and open-door functional) (Open-door functional, Thumper Firing, Lunar Noon)
173/2589	Final Test Report-ASE EMI
174/2590	Final Test Report-ASE Mass Properties
175/2591	Final Test Report-Pre-Vibration Functional Tests
176/2592	Final Test Report-Induced Environments Tests
177/2593	Final Test Report-Post-Induced Environment Tests
178/2599	Final Test Report-D-2/M-5 Qualification Fuel Cask Assy
179/2606	Final Test Report-D-2/M-5 Flight Model Fuel Cask Assy
180/2608	Final Test Report-Flight #4 Central Station Power Dissipation
181/2609	Final Test Report-Flight #4 Thermal/Vacuum Acceptance Test
182/2610	Final Test Report-Flight #4 Sub Pkg. #1 Mass Properties
183/2611	Final Test Report-Flight #4 Sub Pkg. #1 Vibration Acceptance
184/2612	Final Test Report-Flight #4 Sub Pkg. #1 Tumble Test
185/2613	(CANCELLED)
186/2614	Final Test Report-Flight #4 System EMI
187/2615	Final Test Report-Flight #4 Antenna VSWR (Pre-T/V)
188/2616	Final Test Report-Flight #4 Antenna VSWR (Post-T/V)

ATR/BSR No.Title

189/2623	(CANCELLED)
190/2622	(CANCELLED)
191/2624	(CANCELLED)
192/2625	(CANCELLED)
193/2626	(CANCELLED)
194/2627	(CANCELLED)
195/2629	Final Test Report-Flight #1 Model Fuel Cask Assy
196/2630	Final Test Report-Flight BU Model Fuel Cask Assy
197/2631	Final Test Report-Flight #2 Model Fuel Cask Assy
198/2632	Final Test Report-Flight #2 Model Fuel Cask Assy
199/2633	Final Test Report-Flight #4 Model Fuel Cask Assy
200/2634	Final Test Report-Flight Qualification Model Fuel Cask Assy
201/2653	Final Test Report-Flight No. 1 - Recalibration IST
202/2654	Final Test Report-Flight #1-Recalibration Radiated Power
203/2677	Final Test Report-Flight #3 Modified IST and RF Link Verification Test
204/2678	(CANCELLED)
205/2679	(CANCELLED)
206/2940	Final Test Report-Flight 4 MIST (Recalibration)
207/2693	Final Test Report-CPLEE T/V Retest (Qual SB)
208/2694	Final Test Report-Integrated System Test Flight #4
209/2709	Final Test Report-MSFN/ALSEP Compatibility SIT

ATR/BSR No.Title

210/2710	Final Test Report-Flt #1 MSFN
211/2711	Final Test Report-Test Model MSFN (with Experiments)
212/2712	Final Test Report-Flight #3 MSFN
213/2713	Final Test Report-Flight #4 MSFN
214/2935	Final Test Report-Flight #4 Thermal Vacuum Test Rerun
215/2729	ALSEP Qualification C Test Summary Report
216/2924	Final Test Report Qualification C System EMI
217/2865	Central Station Power Dissipation
218/2866	Integrated Systems Test (with Integrated Power Unit)
219/2867	System EMI
220/2868	S/P #1 Mass Properties
221/2869	S/P #2 Mass Properties
222/2870	S/P #1 Vibration
223/2871	S/P #2 Vibration
224/2871	S/P #2 Vibration
224/2872	S/P #2 Tumble
225/2873	S/P #2 Tumble
226/2874	S/P #1 Magnetic Properties
227/2875	S/P #2 Magnetic Properties
228/2876	S/P #2 Magnetic Properties - Rerun
229/2877	S/P #2 Boydbolt Verification
230/2878	Thermal Vacuum Acceptance

ATR/BSR No.Title

231/2879	Post-Vibration Mod IST
232/2880	Pre-Shipment Mod Integrated Systems Test and Antenna Radiated Power
233/2881	S/P #2 Tumble (Rerun)
234/2882	Qualification on Resettable Solid State Timer (Vendor)
235/2899	Qual C EMI Retest Report
236/2950	Qual-MUX (2341956)
237/2961	EMI Testing of the ASE Electro-Explosive Devices (DVT Model)
238/2973	Antenna VSWR: Antenna Aiming Mech. Test
239/2974	RTG Leak & Functional
240/2975	(CANCELLED)
241/2976	(CANCELLED)
242/2977	(CANCELLED)
243/2978	(CANCELLED)
244/2979	(CANCELLED)
245/2980	(CANCELLED)
246/2981	(CANCELLED)
247/2982	(CANCELLED)
248/2989	Apollo 14 LRRR Qual Model Mass Properties
249/2990	Apollo 14 LRRR Qual Model Acceptance Level Vibration & Visual Inspection

ATR/BSR No.Title

250/2991	Apollo 14 LRRR Qual Model Design Limit Vibration & Visual Inspection
251/2992	Apollo 14 LRRR Qual Model Shock Test
252/2993	Apollo 14 LRRR Qual Model Deployment Mechanical Function
253/2994	Apollo 14 LRRR Flight Model Acceptance Level Vibration & Visual Inspection
254/2995	Apollo 14 LRRR Flight Model Mass Properties
255/2996	Apollo 14 LRRR Flight Model Tumble Test
256/2997	Apollo 14 LRRR Flight Model Deployment, Mechanical Function
257/2999	Apollo 14 LRRR UHT Socket Load Test
258/3011	ALSEP Array D S/P #2 Qual Test Report - HFE PIA/Mass Properties
259/3012	ALSEP Array D S/P #2 Qual Test Report-S/P #2 Acceptance Vibration (Non-Operating)
260/3013	ALSEP Array D S/P #2 Qual Test Report - Qual Vibration (Non-Operating)
261/3014	ALSEP Array D S/P #2 Qual Test Report - Qual Shock (Non-Operating)
262/3015	ALSEP Array D S/P #2 Qual Test Report - Boydbolt Verification
263/3016	ALSEP Array D S/P #2 Qual Test Report - S/P #2 Magnetic Properties
264/3017	ALSEP Array D S/P #2 Qual Test Report - Antenna Aiming Mechanism, Functional
265/3037	Operations Plan for ALSEP Array A-2

<u>ATR/BSR No.</u>	<u>Title</u>
266/3060	Qual Test Program Report (A-2) ALSEP Data (Qual) Transmitter Part #2344600-2345250
267/3101	Resettable Solid State Timer Reliability Test
268/3102	300 Array LRRR Qualification Test Report - Mass Properties
269/3103	ALSEP 300 Array LRRR Qualification Test Report - Visual Inspection Acceptance Level Vibration
270/3104	ALSEP 300 Array LRRR Qualification Test Report - Qualification Level Vibration & Visual Inspection
271/3105	ALSEP 300 Array LRRR Qualification Test Report - Design Limit Shock
272/3106	ALSEP 300 Array LRRR Qualification Test Report - Mechanical Functional Deployment.
273/3108	S/P #2 Mass Properties (Rerun)
274/3109	S/P #2 Vibration (Rerun)
275/3121	Mass Properties ALSEP 300 Array LRRR Flight Model Test Report
276/3122	Acceptance Level Vibration Visual Inspection ALSEP Array LRRR 300 Flight Model Test Report
277/3123	Tumble Test ALSEP Array LRRR 300 Flight Model Test Report
278/3124	Mechanical Functional Deployment ALSEP Array LRRR 300 Flight Model Test Report
279/3131	S/P #2 Boydbolt Verification of January 29, 1971
280/3132	S/P #2 UHT Fit Check with Test Procedure 2338623 of 29 January 1971
281/3134	ASE Magnetic Properties - Array A-2 (2345123)

ATR/BSR No.Title

282/3135	Final Test Report-S/P #2 Array D Boydbolt Verification Fit Check with ALSEP Tools with S/P #2
283/3137	Final Test Report-MSFN (SIT) Test on ALSEP Flight System A-2
284/3138	Final Test Report-Mass Properties Determination Tumble & Acceptance Vibration (Array D S/P #2 Flight)
285/3139	Final Test Report-Post Vibration Functional Tests for HFE, RTG & Antenna Aiming Mechanism (S/P #2 Array D Flight)
286/3140	Final Test Report-Mass Properties Determination, Exceptance Vibration & Tumble Tests (Array D S/P #1 Flight)
287/3142	Final Test Report-S/P #1 Modified Integrated System Test & Post Vibration PIA for the LSM Experiment
288/3143	Final Test Report-Boydbolt Verification & ALSEP Tools Fit Checks (Array D S/P #1 Flight)
289/3149	Final Test Report-ALSEP Deployed System Magnetic Properties Test (Array D Flight)
290/3160	Final Test Report-System EMI & Crosstalk (Array D Flight)
291/3161	Final Test Report-16 Channel ASE Multiplexer S/N 13 Qual Test Program for Array D
292/3162	Final Test Report-Dual 90 Channel ASE Multiplexer S/N 15 Qual Test Program for ALSEP Array D
293/3201	Operations Plan - ALSEP Array D
294/3216	ALSEP Redundant Command Receiver Qual Test Report
295/3217	Final Test Report-ALSEP Array D SP #2 Mass Properties & ASE Mass Properties

<u>ATR/BSR No.</u>	<u>Title</u>
296/3218	Final Test Report-ALSEP Array D HFE Functional, RTG Functional & RTG Leak Tests
297/3219	Final Test Report-Array D TGA and MPA Vibration & Post Vibration Tests
298/3220	Final Test Report-Array D Tool Carrier Vibration & Cable Cannister Vibration
299/3221	Final Test Report-Array D Post T/V Tests-Antenna Aiming Mech. , RTG Leak, Antenna VSWR & MBA Functional.
300/3222	Final Test Report-Array D MIST & Radiated Power Tests
301/3223	Final Test Report-ASE Thumper Geophone Assembly T/V Test
302/3224	Final Test Report-ALSEP Program ASE Mortar Box Assembly T/V Test
303/3230	Final Test Report-LSPE Explosive Package EED/RFI Design Verification Test (CCP 273 Item B-5)
304/3232	Final Test Report-ALSEP PSE Connector Temperature Test
305/3233	Final Test Report-ALSEP Crew Fit & Functional Test & Restowage
306/3234	Final Test Report-ALSEP Thermal/Vacuum Integrated System Test Array D
307/3239	Final Test Report-PSE Sensor Visual Inspection-S/N 8
308/3276	(KSC Report) Final Test Report-MSFN(SIT) Test on ALSEP Flight System 5
309/3307	Final Test Report-Antenna Aiming Mech. Functional (2365562)
210/3308	Final Test Report-Short Plug Functional (2365563)
311/3309	Final Test Report-S/P #2 Mass Properties (2365567)

APPENDIX C

CENTRAL STATION ELECTRONICS
EFFECTIVITIES

2-3-72

CONFIG OR ARRAY	MODEL	SERIAL NUMBER																												
		2330509		2330521		2330527		23304500		2330000		2330524		2330523		2330526		2330525		233----		2330416		2330307		233A822		2330309		
		C/D	I.D	D/P	I.D	XMTR	FREQ	P.DU	P.C.U	MUX	RCVR	DIP SW.	DIP FTED	HARNESS	TIMER	ANTENNA	ANT. LABEL	ADBY	AIMING	MACH										
A	PROTOA	1	1	2	A7	546	CH-1	2	(-1) 1	5	3	2	3	(250-2) 1	A23344	2	2R		2											
B	PROTO B	1	1	2*	A7	546	CH-1	2	(-1) 1	5	3	2	3	(4794-1) 2	A23344	2	2R		2											
C	PROTOC	1	1	2*	A7	546	CH-1	2	(-1) 1	5	3	2	3	(4794-2) 4	A23344	2	2R		2											
A	QUAL A	2	2	3	A1	748	CH-1	4	(-3) 3	7 ⁰⁰	4	5	5	(250-2) 3	J79615	4	4		4											
B	QUAL SB	1	1	2*	A7	546	CH-1	2	(-1) 1	5	3	2	3	(4794-1) 2	A23344	2	2R		2											
-	QUAL BU	3	1	4	A4	8	CH-1	3	(-3) 2	6	-	-	-	-	-	-	-	-	-											
A	QUAL SA	2	2	3	A1	743	CH-1	4	(-3) 3	8	4	5	5	(250-2) 3	J79615	4	4		4											
A	FLIGHT 1	4	1	6	A2	12814	CH-2	6	(-3) 4	9	6	6	6	(250-2) 7	E44261	7	7		7											
	EASEP	5	2	7	A3	11215	CH-1	8	(-3) 5	10	10	11	10	(250-2) 8	E46223	9	9		9											
B	FLIGHT 3	6	3	8	LS	17818	CH-3	7	(-3) 6	12 ⁰	7	10	7	(4794-1) 9	E4432B	10	10		10											
C	FLIGHT 4	7	4	9	B6	13420	CH-4	9	(-3) 7	14	9	8	11	(4794-2) 10	E44014	6	5		6											
	SPARES			4+	A3	10	CH-1	5***	(-3) 8	13	8	7	8	-	E35205	11	6		9											
C	SPARES	9	4	11	B7	16	CH-4	10																						
A-2	FLT A2	9+	2	12	A3	26227	CH-5	10	(-3) 9	11 ⁰⁰	11	9	9	2344956	2338511	11	11		7											
D	FLT 5	8	5	11++	A1	28229	CH-6	11	(-3) 8	2345500	2345147	7	8	2345164	8204-008	5	5		9											
	QUALD									15***	14																			
A-2/D	SPARES	3	3	4	B5	30231	CH-3			13	15				8064007															
		2367600	2369400	2362877		2362200	2368101			2345147				2362352																
E	QUAL	11	6	14	A4	41821	CH-3	13	11		17	12	12	14		13	13		12											
	FLT	12	6	15	A4	42843	CH-3	14	12		15	13	13	15		14	14		13											
	SPARES	13	6	16	A4	4445	CH-3	15	13		18	14	14			15	15		15											

CONFIG A: LEAD(2) HFE(3) LMS(1) LSG(4) LSP(5)
 CONFIG B: PSE(1) SIDE(4) SWS(3) LSM(2)
 CONFIG C: PSE(1) ASE(2) HFE(1) CPLEE(4)
 CONFIG D: PSE(1) ASE(2) LSM(3) HFE(4)
 CONFIG A-2: PSE(1) SIDE(4) SWS(3) LSM(2) HFE(5)
 * S/N 2 HAS BEEN REWORKED TO B/C CONFIGURATION
 ** NEW MUX FOR FLT'S ARRAY D (BENOX DESIGN)
 *** S/N 5 HAS UNTWANGED BACKLOCK RELAYS AND IS NOT ASSIGNED
 0 MUX MODIFIED NEW PART NO. 234578

FREQUENCY ALLOCATION	C/D ADDRESS I.D.NOS	D/P I.D.NOS	00 REDESIGNED BY A PART NO. 7338900 (DYNATRONICS) BENOX
CH-1 = 2276.5 MHz.	1 = OCTAL 130 & 30	A-1 = 0 0 1	+ TO BE REWORKED FOR ARRAY A-2
CH-2 = 2278.5 MHz.	2 = OCTAL 116 & 16	A-2 = 0 1 0	** TO BE REWORKED FOR FLT'S OR ARRAY "D"
	3 = OCTAL 151 & 51	A-3 = 0 1 1	TBA - TO BE ASSIGNED
CH-3 = 2275.5 MHz.	4 = OCTAL 25 & 65	A-4 = 1 0 0	C/D 5 - NEW PROPOSED ADDRESS FOR ARRAY "D"
CH-4 = 2279.5 MHz.	5 = OCTAL 62 & 144	B-5 = 1 0 1	+++ B/A BUILT WITH # 2345250 START WITH S/N 26
CH-5 = 2278.0 MHz	6 = OCTAL 151	B-6 = 1 1 0	000 DVM PART NOS FOR CD-2349300; DP-2349200;
CH-6 = 2276.0 MHz		B-7 = 1 1 1	PLU-2299100 PLU 2299100 S/N ONE LOWER THAN QUAL

APPENDIX D

ALSEP SERIAL NO. ALLOCATION

DATE 11 FEB 70 N.V.D.

REV. 2-6-70

ALSEP SERIAL NO. ALLOCATION

SHT 1 OF 20

MAJOR ASSY.	MODEL	PROTO	QUAL	QUAL	QUAL	FLT	FLT	FLT	FLT	D-2	E-2	F	F	D-2			
	CEI	ABC	ABC	B.U.	SA	1	2	3	4	LM-4	ABC	REFB	NEW	FLT.	1	2	3
CENT. STA. ELECT. CONF. A 2330399-2		S/N 2	S/N 3		S/N 4	S/N 5	S/N 6										
		PROTO A	QUAL A														
CENT. STA. ELECT. CONF. B 0399-4		S/N 2 REFURB TO-A PROTO B	S/N 2 REFURB TO-A QUAL B B						S/N 6 -4								
CENT. STA. ELECT. CONF. C 8199		S/N 2 REFURB TO-C															
CENT. STA. ELECT. CONF. C 0393-5									S/N 7								
THERMAL PLATE ASSY 0351-1		S/N 1 -1 PROTO A	S/N 1 -2 QSB	N/A	S/N 2 -2	S/N 3 -2	S/N 4 -2										
THERMAL PLATE 037 5823									S/N 5 -1	S/N 6 -2							
THERMAL BAG 0333		S/N 2 PROTO ABC	S/N 2 QSB S/N 5 QUAL C		S/N 5	S/N 3	S/N 4	S/N 6	S/N 7								2 SP1 (FG)
COMMAND REC'VR. 0523		S/N 3 PROTO ABC	S/N 3 QSB		S/N 4	S/N 6	S/N 8	S/N 7 (10)	S/N 9		NOTE: S/N 11 TO A-2 S/N 10 TO EASE S/N 8 HELD ON OPEN FA						8 SP1 SP2 (FG)
MULTIPLEXER CONVERTER 0524		S/N 5 PROTO ABC	S/N 5 QSB	S/N 7	S/N 8 * (MSFN)	S/N 9 (NOTE S/N 7 WAS ORIGINAL)	S/N 10 (EASE)	S/N 12 AS ORIGINAL	S/N 11	NOTE: S/N 12 MODIFIED TO P/N 231578 SEE P. 2 THRU OUT QSA TESTS)							11 SP1 SP2 (FG)
DIPLEXER FILTER 0525		S/N 3 PROTO ABC	S/N 3 QSB		S/N 5	S/N 6	S/N 8	S/N 7 (10)	S/N 11	NOTE: S/N 9 TO A-2 S/N 10 TO EASE							2 SP1 SP2 (FG)
DIPLEXER SWITCH 0526		S/N 2 PROTO ABC	S/N 2 QSB		S/N 5	S/N 6	S/N 8	S/N 10	S/N 8	NOTE: S/N 9 TO A-2 S/N 11 TO EASE							7 SP1 SP2 (FG)
TRANSMITTER 0527 2 EA. REQ'D.		S/N 5 S/N 6 PROTO ABC	S/N 5 S/N 6 QSB		S/N 7 S/N 9	S/N 12 S/N 14	S/N 10 S/N 20	S/N 17 S/N 18	S/N 20 S/N 19 (1815)	NOTE: S/N 11 & 15 TO EASE							16 SP1 SP2 (FG)

NOTE: S/Ns WITH () INDICATE THOSE S/Ns USED DURING ACCEPT. TESTS ON FLT 2, 3 & 4

Reproduced from
 best available copy.

DATE 11-14-68 REV. B
REV. 5-9-70

ALSEP SERIAL NO. ALLOCATION

SHT 3 OF —

MAJOR ASSY. MODEL	PROTO	QUAL	QUAL B.U.	QUAL SA	FLT 1	FLT 2	FLT 3	FLT 4	D-2 LM-4	E-2 ABC	F REFB	F NEW	OTHER					
	S/N 1	S/N 2	S/N 3	S/N 4	S/N 5	S/N 6	S/N 7	S/N 8	S/N 9	S/N 10	S/N 11	S/N 12	S/N 14	1	2	3		
CENTRAL STA. TIMER 7330626	A23344 PROTO A.B.C.	A23344 QSB		J79615	E49261	J96223	E44328	E44000									SA1 E35205	
TIMER BATTERY 4476	S/N 1 PROTO A.B.C.	S/N 1 QSB		S/N 2	S/N 1 LOT 0714	S/N 2 LOT 2764 (EASEP)	S/N 1 LOT 1569	S/N 1 LOT 0270										
BATTERY/TIMER ASSY 4729	S/N 1 PROTO A.B.C.	S/N 1 QSB		S/N 2	S/N 3	S/N 4	S/N 5	S/N 6										
HARNES ASSY 1250-2	S/N 1 PROTO A	S/N 3 QUAL A		S/N 3	S/N 7	S/N 8 (EASEP)												
HARNES ASSY CONFIG B 4794-1	S/N 2 PROTO B	S/N 2 QSB					S/N 9											
HARNES ASSY CONFIG C 4794-2	S/N 4 PROTO C							S/N 10										
SWITCH ACTUATOR 4700	S/N 2 PROTO A.B.C.	S/N 2 QSB		S/N 3	S/N 4	S/N 5	S/N 6			E-2A S/N 9 E-2B S/N 2	NOTE:	S/N 5 TO A-2	ALLOCATE					
SWITCH ACTUATOR CONFIG C 5825		S/N 8 QUAL C						S/N 7										
PCU 0000-1	S/N 1 PROTO A.B.C.	S/N 1 QSB																
PCU 0000-3		S/N 3 QUAL A	S/N 2	S/N 3	S/N 4	S/N 5 (EASEP)	S/N 6	S/N 7	NOTE:	S/N 2 WAS ORIGINALLY IN QUAL A S/N 8 TO A-2							8 SA1 (LT)	
COMMAND DECODER 0509	S/N 1 PROTO A.B.C.	S/N 1 QSB		S/N 2	S/N 4	S/N 5 (EASEP)	S/N 6	S/N 7	NOTE:	S/N 9 ALLOCATED TO A-2							3 SA1 (LT)	
PDU 0450-2	S/N 2 PROTO A.B.C.	S/N 2 QSB	S/N 3	S/N 4	S/N 6	S/N 7 (EASEP)	S/N 7	S/N 9 (8)	NOTE:	S/N 3 WAS ORIGINALLY IN QUAL A S/N 8 TO EASEP							5 SA1 (LT)	

DATE 11-4-68 REV. B
REV. 1-30-70

ALSEP SERIAL NO. ALLOCATION

SHT 6 OF 6

MAJOR ASSY. - CEI	PROTO	QUAL	QUAL B.U.	QUAL SA	FLT 1	FLT 2	FLT 3	FLT 4	D-2 LM-4	E-2 ABC	F UNITS	F UNITS	F-2 FLT	OTHER		
														1	2	3
SUNSHIELD ASSY CONFIG C 2335830	S/N 1 PROTO C	S/N 2 QUAL C	S/N 3	S/N 4	S/N 5	S/N 6	S/N 7	S/N 8	S/N 9	S/N 10	S/N 11	S/N 12	S/N 14			
THERMAL CURTAIN RIGHT 0355	S/N 1 PROTO A	S/N 2 QUAL A														
THERMAL CURTAIN LEFT 0356	S/N 1 PROTO A	S/N 2 QUAL A														
THERMAL CURTAIN RIGHT 5582				S/N 3	S/N 4	S/N 5	S/N 6	S/N 5		S/N 8	NOTE: S/N 7 TO A-2					
THERMAL CURTAIN LEFT 5609				S/N 3	S/N 4	S/N 5	S/N 6	S/N 5		S/N 8	NOTE: S/N 7 TO A-2					
VISOR ASSY FRONT 2990	S/N 1 PROTO A	S/N 2 QUAL A														
REEL DUST DETECT. 0173	S/N 1 PROTO A, B, C	S/N 1 QSB		S/N 4	S/N 5	S/N 6	S/N 7	S/N 8		S/N 9 E 2 B S/N 1						
SUB PKG II ASSY 0201	S/N 1 PROTO A	S/N 2 QUAL A ALLOTE TO EASEP														
SUB PKG II ASSY 4849-1-3				S/N 3	S/N 4	S/N 5		S/N 5 REFURB TO-3 WAS SAT								S/N 7 IN STORES
SUB PKG II ASSY CONFIG B 4844-1-2		S/N 3 REFURB TO QSB						S/N 8 -2								
SUB PKG II ASSY 4842									S/N 9				S/N 12			
SUB PKG II ASSY 3673-1 DEPLOYED 3673-2 NON DEPLOY.										S/N 10-1						
										S/N 11-2						

DATE 11-14-68 REV. B
 REV. 11-20-69

ALSEP SERIAL NO. ALLOCATION

SHT 7 OF —

MAJOR ASSY.	MODEL	PROTO	QUAL	QUAL B.U.	QUAL SA	FLT 1	FLT 2	FLT 3	FLT 4	D-2 LM-4	E-2 ABC	F UNIT	F	OTHER			
	CGI	S/N 1	S/N 2	S/N 3	S/N 4	S/N 5	S/N 6	S/N 7	S/N 8	S/N 9	S/N 10	S/N 11	S/N 12	S/N 14	1	2	3
SUNSHIELD ASSY NON DEPLOYED 2333750											S/N 11						
SUNSHIELD ASSY DEPLOYABLE 3756											S/N 12						
THERMAL CURTAIN LEFT 5701		REWORK PROTO A S/N 1	S/N 1 QSB								QSB S/N 1 USED ON E2B						
THERMAL CURTAIN RIGHT 5702		REWORK PROTO A S/N 1	S/N 1 QSB								QSB S/N 1 USED ON E2B						
SUNSHIELD ASSY 2334051											REFURB S/N 9						
SUNSHIELD ASSY CASSIS B DEPLOYED 4010											S/N 13						
SUB PKG II DEPLOY. 2341452											REFURB QSB S/N 3 FOR E2B						
SUB PKG I NOW DEPLOY. 2334020											S/N 15 E2B						
SUB PKG I DEPLOY. 2341130											S/N 14 E2B						
PRIMARY STRUCT. 2341425											REFURB QSB S/N 1 FOR E2B						
PRIMARY STRUCT 2341970											REFURB S/N 14 (INTEGRAL) FOR E2C						

DATE 11-14-68 REV. B

REV. 1-4-71

ALSEP SERIAL NO. ALLOCATION

SHT 10 OF

	MODEL	PROTO	QUAL	QUAL B.U.	QUAL SA	FLT 1	FLT 2	FLT 3	FLT 4	D-2 LM-4	E-2 ABC	F UNIT1	F UNIT2	D-2 FLT	OTHER		
		S/N1	S/N2	S/N3	S/N4	S/N5	S/N6	S/N7	S/N8	S/N9	S/N10	S/N11	S/N12	S/N14	1	2	3
MAJOR ASSY	CEI																
SUB PALLET ASSY 2335463					S/N3	S/N4	S/N5		S/N5 WAS S/N6		NOTE: S/N6 TO A-2						S/N6 IN STORES
STRUCT. CARRIER ASSY CONFIG B 8070-143			S/N2 QSB -1						S/N3 -2								
ANT. GIMBAL PKG 3303		S/N1 PROTO A	S/N2 QUAL A														
ANT. GIMBAL PKG 5354					S/N3	S/N4	S/N5		S/N5 WAS S/N6		NOTE: S/N6 TO A-2						S/N6 IN STORES
CONTAINER ASSY AIM. MECH. 5765			S/N1 QSB						S/N1								
HELICAL ANT. 0307		S/N2 PROTO A B C	S/N2 QSB (EASEP)		S/N4	S/N7	S/N9 (EASEP)	S/N10	S/N6	NOTE: S/N2 ALLOCATED TO EASEP QUAL MODEL S/N1 TO QUAL C					5 SPJ FLT		
ANTENNA CABLE 0308		S/N2 PROTO A B C	S/N2 QSB		S/N4	S/N7	S/N9	S/N10	S/N5								6 SPJ FLT
ANT. AIMING MECH. 0309		S/N2 PROTO A B C	S/N2 QSB		S/N4	S/N5	S/N7	S/N8	SEE PG 11		NOTE: S/N7 TO A-2						9 SPJ FLT
FUEL CASK 4850 REURB TO 8433		S/N2 PROTO															
FUEL CASK 8660					S/N4 TO E-2 C	S/N4	S/N5	S/N6	S/N7	S/N10	NOTE: S/N8 TO A-2						10 SPJ FLT
FUEL CASK 5389												S/N11					
ASTRONAUT GUARD 8350			S/N1 QUAL		SEE PAGE 11					S/N2				S/N3			

DATE 11-14-68 REV. B
 REV. 11-28-69

ALSEP SERIAL NO. ALLOCATION

SHT 12 OF

MAJOR ASSY.	PROTO	QUAL	QUAL B.U.	QUAL SA	FLT 1	FLT 2	FLT 3	FLT 4	D-2 LM-2	E-2 ABC	F UNIT1	F UNIT2	OTHER			
	S/N 1	S/N 2	S/N 3	S/N 4	S/N 5	S/N 6	S/N 7	S/N 8	S/N 9	S/N 10	S/N 11	S/N 12	1	2	3	
EHT 2332446	S/N 1 PROTO A, B, C															
TDRT 3260	PROTO G															
CASK CAP REMOVAL TOOL 7954	S/N 1 PROTO A			S/N 2	S/N 3	S/N 4		S/N 4 WAS S/N 6					NOTE: S/N 6 TO A-2 9 SP1			
CASK CAP REMOVAL TOOL CONFIG B 2002	REFURB S/N 1 TO PROTO B	REFURB S/N 2 TO QSB						S/N 5								
FUEL XFER TOOL 5438	S/N 1 PROTO A			S/N 2	S/N 3	S/N 4		S/N 4 WAS S/N 6					NOTE: S/N 6 TO A-2 15 SP1 FLY			
FUEL XFER TOOL CONFIG B 8089	REFURB S/N 1 TO PROTO B	S/N 2 FOR QSB						S/N 5								
REL. HANDLING TOOL 2 EA REQ'D. 8102	S/N 1 & 2 PROTO B	(1) S/N 1 (2) S/N 2 FOR QSB		S/N 3 & 4	S/N 5 & 6	S/N 7 & 8	S/N 9 & 10	S/N 11 & 8 WAS S/N 11 & 12					NOTE: S/N 11 & 12 TO A-2 7 IN PROG MATEL			
HFE CONFIG B 0661	S/N 2 PROTO B	S/N 2 QSB	S/N 3 QUAL SPARE					S/N 5					DVT. S/N 1	4 SP1	6 SP2	7 IN PROG MATEL
HFE CONFIG B THERMAL BAG 1517	S/N 3 PROTO B	S/N 3 QUAL SB	S/N 4 QUAL SPARE					S/N 5					S/N 1 DVT	6 SP1	7 SP2	IN PROG MATEL
HFE CONFIG B ELECTRONICS 3126	S/N 2 PROTO B	S/N 2 QUAL SB	S/N 3 QUAL SPARE					S/N 5					S/N 1 DVT	4 SP1	6 SP2	7 IN PROG MATEL
HFE CONFIG B PROBE PKG 3127	S/N QSB PROTO B	S/N QSB QSB	S/N QSB QUAL SPARE					S/N F2SB					PB DVT	6 SP1	7 SP2	IN PROG MATEL

DATE 11-10-70 REVD

REV. 8-17-70

ALSEP SERIAL NO. ALLOCATION

SHT 16 OF

MODEL	MAJOR ASSY	PROTO	QUAL	QUAL B.U.	QUAL SA	FLT 1	FLT 2	FLT 3	FLT 4	D-2 LM-4	E-2 ABC	F	F	OTHER												
														S/N 1	S/N 2	S/N 3	S/N 4	S/N 5	S/N 6	S/N 7	S/N 8	S/N 9	S/N 10	S/N 11	S/N 12	1
	MORTAR BOX ASSY 2334499-2																	DVT S/N 1								
	MORTAR BOX ASSY 4499-4		S/N 7 QUAL C																		349 SR3 (R)					
	THUMPER 1220-3	PROTDC S/N 2																			S/N 1 -2 FOR DVT					
	THUMPER 1220-1		S/N 3 QUAL C																			488 SR3 (R)				
	MORTAR BOX ASSY 4499-3	S/N 2 PROTDC																								
	LTA PARTIAL MODIFIED 8694									S/N 1												2 SR3 (R)				
	THUMPER ELECTRONICS ONLY) 1220-5		S/N 9 QUAL C SPARE																							
	VERTICAL SENSOR & PC BOARD ASSY 8506		S/N 1 QUAL C							S/N 2												S/N 5 IN PROCESS MAY BE				
	GLA INERT FLT TEST 8781-6									S/N 15 (REPAIR)																
	GLA PACKAGE 8507-16-2		S/N 1 -1 QUAL C																			NOTE: S/N 1 HAS BEEN DOWNGRADDED TO ENGR. MODEL AND IS ASSIGNED TO BRIGADY D EDM	S/N 2 -2			344 SR3 FLT SP.

DATE 11-14-69 REV. B
REV. 2-8-71

ALSEP SERIAL NO. ALLOCATION

SHT 17 OF

MAJOR ASSY. CEI	MODEL	PROTO	QUAL	QUAL B.U.	QUAL SA	FLT 1	FLT 2	FLT 3	FLT 4	D-2 LM-4	E-2 ABC	F I F		OTHER				
												S/N 11	S/N 12	1	2	3		
GLA INERT 2330781-4			S/N 16 QUAL C															
GLA 0781-5									S/N 19			NOTE: S/N 17 TO BE STORED AT KSCA SIN PROCESS	S/N 17 (AT KSC)					18120 SPT (EST)
ASE MULTIREG A L 0362	S/N 5 PROTO C S/N 6 PORTABLE	S/N 7 QUAL C ASDS										NOTE: S/N 8 MUX. MODIFIED TO 2341579	S/N 9 DVT S/N 13 IN PROCESS MATE.					11 H SPT (EST)
ASE RE RECEIVER 0263	S/N 3	S/N 6 QUAL C	S/N 8		NOTE: S/N 8 ASSIGNED TO ARRAY D				S/N 5									9 SPT (EST)
ASE GEOPHONE AMP 0818	S/N 3 PROTO C	S/N 4 QUAL C	S/N 5						S/N 7									9 SPT (EST)
ASE ASSOC. NECESSARY 3318	S/N 3 PROTO C	S/N 4 QUAL C	S/N 5						S/N 7									9 SPT (EST)
ASE MUX/MULTIREG MODIFIED 2341579									S/N 8									2341579 (S/N 8) CAN BE INTERCHANGED WITH 2330862 S/N 11 & 10 IN ASE. FLT OR SPORE CENTRAL ELECTRONICS.
MODIFIED CPLEE 2338975									S/N 5									
SWS 0658	S/N 3	S/N 9			S/N 6	S/N 8	S/N 9											7 SPT
LSM 0657	S/N 1	S/N 2			S/N 2	S/N 6												4 SPT
S.I.D.E. 0650	SYS. 2 S/N 2 PROTO C				SYS. 3 S/N 1	SYS. 4 S/N 4	SYS. 5 S/N 5			SYS. 5 S/N 5								5 FLT 4 SP.
CPLEE. CONFIG B & C 0662	S/N 1 PROTO C	S/N 2 ASB S/N 1 QUAL C	S/N 4 QUAL SPARE						S/N 6	S/N 3 SEE ROUTE								3 SPT 7 IN PROCESS MATE.

DATE 6-11-69
 REV. 10-23-70

ALSEP SERIAL NO. ALLOCATION

SHT 20 OF

MAJOR ASSY.	PROTO	QUAL	QUAL	QUAL	FLT	FLT	FLT	FLT	D-2	E-2	F	F	S/N 14	SPARES			
	A B C	A B C	B. U.	S A	1	2	3	4	LM-4	ABC	REFD	NEW		1	2	3	
	S/N 1	S/N 2	S/N 3	S/N 4	S/N 5	S/N 6	S/N 7	S/N 8	S/N 9	S/N 10	S/N 11	S/N 12					
PSS ASSY THERMAL SHROUD ASSY 2338760					S/N 5 -2	S/N 7 (EASEP)	S/N 6 -6	S/N 4 -7								3 S/P -5	
PSE SENSOR ASSY (1668 REF) 8146	P-2	P-2 QSB (EASEP)		S/N 2	S/N 5	S/N 7	S/N 6	S/N 3			NOTE: S/N 1 TO 12				4 S/P IN ORG. MAT.		
SENSOR ASSY 2341604 NEW (ELE. 233425 REF.)	P-2	P-2 QSB (EASEP)		S/N 2	S/N 5	S/N 7	S/N 6	S/N 4 -501							3 S/P		
PSE SHROUD & GACHEN ASSY 8016		S/N 5 QSB (EASEP)			S/N 6	S/N 8 (EASEP)	S/N 11 -501	S/N 12 -501		S/N 5 329	SHROUDS DAMAGED IN TV CHAMBER						13
PSE DUMMY SENSOR 8771		REFURB EM 3 FOR QSB QUAL C															
PSE ELECTRONICS (ELE. 234690-S/N REF) 4670	P-2	P-2 QSB		S/N 1	S/N 4	S/N 6 (EASEP)	S/N 5	S/N 3								2 S/P	
PSE STOOL ASSY 3795											S/N 8						
PSS ASSY THERMAL SHROUD ASSY 8460-1	P-2 PROTO B	P-2 QUAL C															
PSS ASSY THERMAL SHROUD ASSY 8460-4		P-2 QSB															
PSS ASSY THERMAL SHROUD ASSY 8460-3				S/N 2													
RTG ASSY MODIFIED 2341458											S/N 1 E2B						
PSE SHROUD & GACHEN ASSY 2341432											REFURB S/N 3 E-2B						

ALSEP SERIAL NUMBER ALLOCATION (A-2 SUPPLEMENT)

DATE 9-4-69
SHT 1 OF 2

MAJOR ASSY	MODEL	A-2	OTHER	MAJOR ASSY	MODEL	A-2	OTHER	MAJOR ASSY	MODEL	A-2	OTHER	MAJOR ASSY	MODEL	A-2	OTHER
	CEJ	S/N 15			CEJ	S/N 15			CEJ	S/N 15			CEJ	S/N 15	
SUB PKG I 2314986		S/N 16		TRANSMITTER A 2345250* 2344600		S/N 26	SUB S/N 21 S/N 24	THERMAL CURTAIN L. 235609		S/N 7		CASK CAP REMOVAL TOOL 2337954		S/N 6	
MODIFIED SUN- SHIELD ASSY 2344990		S/N 5		TRANSMITTER B 2345250* 2344600		S/N 27		DUST DETECTOR 2341440		S/N 10		FUEL XFER TOOL 2335438		S/N 6	
PRIMARY STRUCT. ASSY 2338947		S/N 13		DATA PROCESSOR 2330521		S/N 4		REEL DUST DETECTOR 2330173		S/N 10		REEL HANDLING TOOL 2 EA. REQ'D. 2338102		S/N 11 11812	
THERMAL PLATE ASSY 2344955		S/N 9		ANALOG MULTIPLEX CONVERTER 2338900		S/N 11	SP S/N 13 QUAL S/N 07	SUB PKG II 2339080		S/N 15		PSE LEVELING STOOL 2344723		S/N 7	9 -501
THERMAL BAG ASSY 2330333		S/N 9		PDU 2330000-3		S/N 9	S/N 8	PALLET ASSY 2334901		S/N 6		UPPER HALF CB 2335471		S/N 6	
HARNESS ASSY 2344956-1		S/N 11		PDU 2330450-2		S/N 10		SUB PALLET ASSY 2335463		S/N 6		LOWER HALF CB 2335476		S/N 6	
CENTRAL STA. ASSY 2344957-1		S/N 8		C/S TIMER 2338511		S/N	SPARE EQUAL TRA	AIMING MECH. PKG 2335354-1		S/N 6		HELICAL ANTENNA 2330307		S/N 11	
SWITCH ACTUATOR 2334700		S/N 5						ANT. AIMING MECH 2338937		S/N 7		FUEL CAPSULE 47D30040161		6330007	
COMMAND DECODER 2330509		S/N 9	S/N 3					ANT. CABLE & THERM. WRAP ASSY 2334522		S/N 11		GENERATOR ASSY 47E300779		6320006	
DIPLEXER SWITCH 2330526		S/N 9		POWER DISSIPATION MODULE 2335637		S/N 8		SHORTING PLUG 2338017		S/N 9	S/N 10	H LHT 3GB39101165		S/N 1005 RETURNED TO MSC	NOTE S/N 1006 RETURNED TO MSC
DIPLEXER FILTER 2330525		S/N 9						FUEL CASK STRUCT 2338160		S/N 6		FLT HANDLING TOOL 47E300452		6331010	
COMMAND RECEIVER 2330523		S/N 11	S/N 8	THERMAL CURTAIN R. 2335582		S/N 7		ASTRONAUT GUARD 2338675		S/N 6		PSS 163V THERM SHROUD ASSY 2338160-5		S/N 1	

△ GFP FLT 2 ○ FROM STORES
△ SPARE UTILIZED

REVISED 3-15-71

ALSEP SERIAL NUMBER ALLOCATION (A-2 SUPPLEMENT)

DATE 9-4-69
SHT 2 OF 2

MAJOR ASSY	MODEL	A-2		OTHER	MAJOR ASSY	MODEL	A-2		OTHER	MAJOR ASSY	MODEL	A-2		OTHER
	C&I	S&I	S&I			C&I	S&I	C&I			S&I	C&I	S&I	
PSE ELECTRONICS (TEL. 234694-50115) 2334670		SN7	SPARE SN2	△	HFE T.C. CABLE		19 20	17 18 SP.						
SWS 2330658		SN7	SN10	△	T.C. REF. SENSOR		H941	H931 SP						
LSM 2330657		SN7		△	HFE PROBE ADL		F3-1 F3-2	F4-1 F4-2 SP						
SIDE MODIFIED 2338104		SN7			HFE SUBPALLET 2339130-101		S/N3							
PSE SHROUD & GROUND ASSY 2338016-501		SN10	SPARE SN13		ASTROMATE CONN. 2339160		SN6	SN7						
PSE SENSOR ASSY (4663 REF) 2341604		SN1	SPARE SN3											
47E301134 GLFC														
HFE 2345430		SN06	SN07 SP. -101 -102											
HFE ELECTRONICS 2333126		SN06	SN07 SP											
HFE PROBE PKG 2333127		F3-B	F4-B SP											
HFE THERMAL GAS 2331517		SN5	SN8 SP											
HFE EMP LMT TOOL		F3T	F4T SP											

△ GFP FLT 2
△ SPARE UTILIZED

REVISED 2-8-71