

Apollo 16 Panoramic Camera

Instrument Overview

The Scientific Instrument Module (SIM) Itek panoramic camera experiment was designed to obtain high-resolution panoramic photographs with stereoscopic and monoscopic coverage of the lunar surface. The panoramic camera, which was housed in the Command Service Module (CSM) SIM bay (Figure 1) and scanned the lunar surface from lunar orbit, also provided supporting photographic data for the other CSM cameras and experiments. The camera provided photographs of 1-m to 2-m resolution from an orbital altitude of 111 km using 127-mm by 1219-mm (5-in. by 48-in.) Black and White 3414 film. The ranges for this camera were (1) focal length, 61 cm (24 in.), (2) field of view, 108 deg cross-track by 10.77 deg along the track scanned, (3) image coverage (from 111 km altitude), 337 km by 21.6 km, (4) image size, 114.8 cm by 11.4 cm (45.2 in. by 4.5 in.), and (5) film capacity, 1981 m (6500 ft) for over 1600 frames. A total of 1587 usable photographs were obtained.

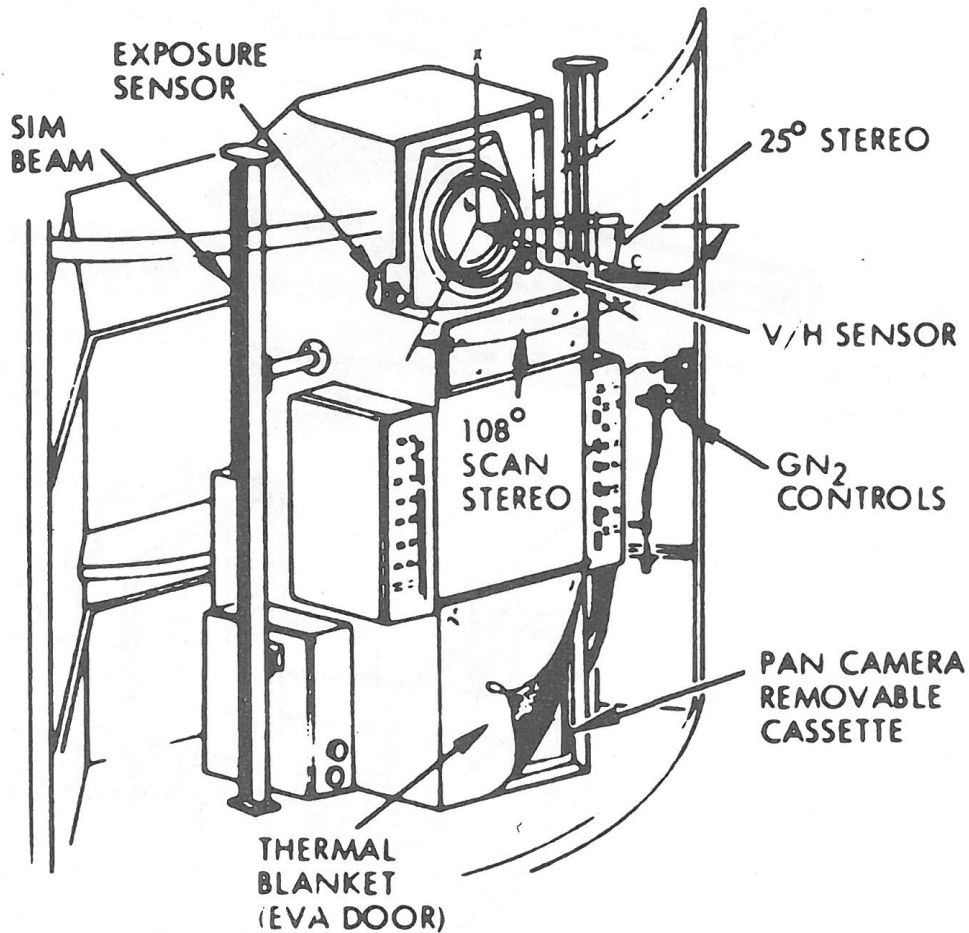

Figure 1 - Panoramic Camera Enclosure and SIM Mounting

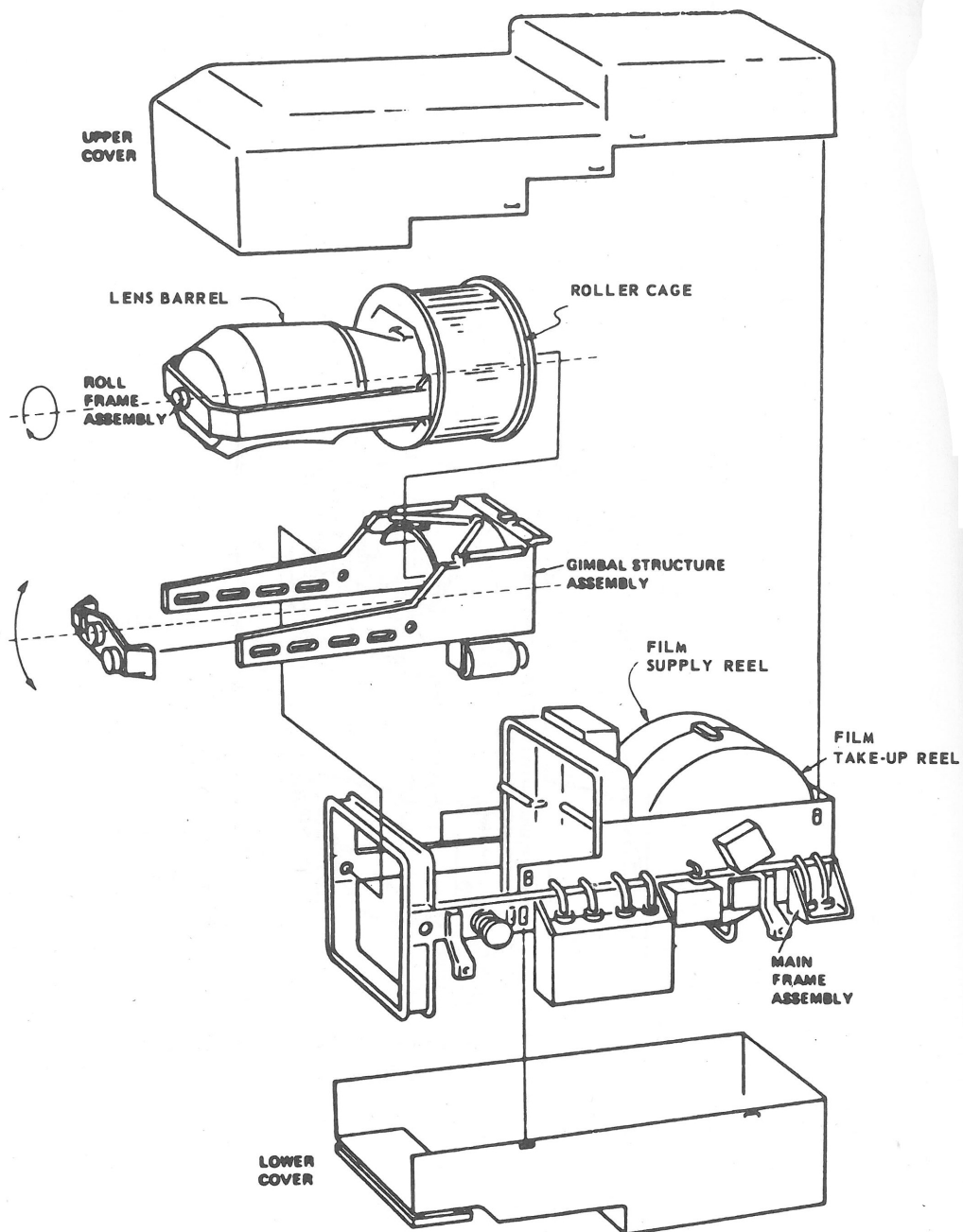

Figure 2 - Principal Components of the Panoramic Camera

The panoramic camera (Figure 2) had four main components: (1) a roll frame assembly that rotated continuously in the cross-track scan direction during camera operation (panoramic scanning), (2) a gimbal assembly that tilted fore and aft to provide stereo coverage as well as forward motion compensation, (3) the main frame, and (4) a gaseous nitrogen pressure vessel assembly required for certain film roller gas bearings. The pressure vessel assembly also was used by the Fairchild mapping camera experiment (Apollo Experiment 16A-03). The camera

optics system, a camera/film drive and control system, and a film cassette completed the panoramic camera system. The lens was an eight-element, field-flattened Petzval type. The film cassette was retrieved by the Command Module Pilot during extravehicular activity (EVA) in the transearth return portion of the mission. The panoramic camera was mounted on structural beams in the CSM SIM bay between the two SIM shelves. It was designed to operate in its SIM-installed position without the use of a deployment subsystem. The camera lens was stowed face-inward to the SIM to protect it from CSM contamination sources. The camera automatically stowed its lens when off-nominal lens thermal conditions were experienced.

Command module camera controls were available for the crew (1) to activate and deactivate camera heaters, (2) to supply or remove primary camera power, (3) to select an operate or standby operation mode, (4) to supply film roller torque to prevent film slack during the launch, translunar injection, and service propulsion system powered flight phases, (5) to activate the five-film frame advance cycle required daily (if camera was not operated in a 24-h period) to prevent film set after film loading, (6) to increase or decrease the width of the camera exposure slit, and (7) to select a stereoscopic or monoscopic mode of operation. A CM display of the barber pole/gray talkback type was provided to enable the crew to verify camera operational status. The images were alternately tilted forward and backward 12.5 deg. in stereo mode to provide 100% overlap with a 25-degree convergent angle. Consecutive frames of similar tilt have 10% overlap.

The Principal Investigator for the Panoramic Camera was Dr. Frederick J. Doyle of the U.S. Geological Survey.

References

Apollo 16 Preliminary Science Report, NASA SP-315, 622 pages, published by NASA, Washington, D.C., 1972.

Apollo Scientific Experiments Data Handbook, NASA Technical Memorandum TM-X-58131, JSC-09166, Eichelman, W. F. and Lauderdale, W. W. (Editors), NASA Johnson Space Center, Houston, Texas, published August 1974, revised April 1976.

Cameron, W. S., E. J. Mantel, and E. R. Miller, Catalog of Lunar Mission Data, NASA Technical Memorandum TM-X-72612, NSSDC 77-02, NASA Space Science Data Center (NSSDC), NASA Goddard Space Flight Center, Greenbelt, Maryland, 1977.

Cameron, W. S., F. J. Doyle, M. A. Nicksch, K. Hug, L. Levenson, and K. Michlovitz, Data User's Note - Apollo 16 Lunar Photography, NSSDC 73-01, NASA Space Science Data Center (NSSDC), NASA Goddard Space Flight Center, Greenbelt, Maryland, 1973.

Source

The NASA Space Science Data Coordinated Archive (NSSDCA, formerly NSSDC) provided this description. Figures 1 and 2 were taken from Cameron et al. (1973).