

Multi-Mission Receiver (MMR)

H. Donnelly and H. Nishimura
Radio Frequency and Microwave Subsystems Section

An introduction to the Multi-Mission Receiver (MMR) is presented. The MMR contains occultation receiver channels (OCC) and very long baseline interferometry (VLBI) channels. The design considerations, performance and implementation of the OCC channels are discussed. The VLBI channels will be discussed in a subsequent report.

I. Introduction

Measurement of the signature of radio signals for obtaining radio science, radio astronomy and tracking data requires extremely stable receiver channels. The Multi-Mission Receiver (MMR) is being developed to provide this capability.

There are two different types of signal signatures that are involved in radio science and in radio astronomy and tracking.

- (1) *Occultation channels.* The first type are narrowband spacecraft transmitted carrier signals. Occultation (OCC) channels used to receive these signals measure the effect of planetary and solar media, interplanetary media, and gravitational fields by detecting minor perturbations on these received signals. Real-time reduction techniques are used in these channels to minimize the data processing costs. This is accomplished by programming the receiver local oscillator based on signal frequency prediction.
- (2) *Very long baseline interferometry channels.* The second type are wide-bandwidth signals received on the very long baseline interferometry (VLBI) channels.

To support these measurements, the MMR contains both OCC and VLBI channels (Fig. 1). Functions such as control, instrumentation and power are common to both sets of channels. The functional requirements and performance, together with a detailed description of the OCC channels, are discussed in this report. The VLBI channels will be discussed in a later report.

II. MMR Occultation Channels

A. General Description

Four occultation channels are being implemented (Fig. 2), right and left hand circularly polarized channels at both S- and X-band. The right-hand channels are equipped with very narrow, narrow and medium bands, while the left-hand channels are equipped with the medium band only. The very narrow-band channels are to be used for measurement of solar media and the narrow-band channels for measurement of planetary media. The medium bands of both the right- and left-hand channels are to be used for measurements during the Saturn ring experiment. In the future, a selection of narrow and very

narrow bandwidths might also be included in the left-hand channel. The selection of bandwidths available (Table 1) provides for all presently known requirements.

B. Design Considerations

The most significant features of the occultation channels are (1) a wide selection of operating bandwidths, (2) the use of one common oscillator to derive the first local oscillator of all channels, and (3) extreme phase stability. These features are discussed in more detail as follows:

1. **Receiver bandwidth selection.** The selection of the operating bandwidth is determined by such characteristics of the received signal as frequency uncertainty and spectral broadening. If a frequency uncertainty exists, the uncertainty at X-band is 11/3 that at S-band. In this situation, narrow and medium bandwidth channels are used and these filter bandwidths are designed with a S- to X-band ratio of approximately 3 to 11. If the signal being tracked has essentially no frequency uncertainty, then the filter bandwidth for both S- and X-bands can be identical, the bandwidth required being determined by spectral broadening. This is the case for the very narrow bandwidth channels.

a. *Narrow and medium bandwidth channels.* A typical filter bandpass response at the 10-MHz IF amplifier is shown in Fig. 3. This response translates directly down to video frequencies. The local oscillator synthesizer is programmed to maintain the signal as close to the filter bandwidth center as the accuracy of the spacecraft's predicted frequency permits. The filters have been designed so that overflow into the operating bandwidth due to image noise in the last mixer or aliasing noise due to digitizing will be at least 20 dB down. This rejection will be increased to 23 dB on future implementations.

b. *Very narrow bandwidth channels.* In contrast to the medium and narrow bands, the very narrow filter bandwidths are the same for S and X. However, since the X-band signal in the IF is offset from the IF center frequency 11/3 as much as the S-band, the filter center frequencies for S and X differ (Fig. 4a). The passband at video frequencies for both the S- and X-bands do not go down to dc (Fig. 4b); however, with undersampling techniques aliasing causes the passband to appear as though it goes down to dc (Fig. 4c) (Ref. 1). With this technique a sampling rate of no greater than 2 BW is required.

2. **Common oscillator.** The mechanization of the local oscillators is similar to the technique used in the Block III open loop receiver; however, the first IF is designed for 300 MHz to accommodate the X-band channels. The oscil-

lator source is a Dana Synthesizer. With the control assembly, the Dana Synthesizer frequency can be programmed to compensate for doppler and maintain the signal within the receiver narrow bandwidth. At present, the controller interfaces directly with the computer in the Radio Science Subsystem. At a latter date, when the MMR controller is implemented, the synthesizer control will interface through the Star Switch Controller to the Radio Science Subsystem.

The synthesizer frequency (Fig. 5) required to maintain the signal within the passband for a narrow or medium bandwidth S-band channel is

$$f_S - f_{LO_S} = 300 \text{ MHz} + \frac{BW_S}{2}$$

where

$$\begin{aligned} f_S &= \text{S-band downlink frequency} \\ f_{LO_S} &= \text{S-band local oscillator frequency} \\ &= f_S - 300 - \frac{BW_S}{2} \\ &= 48 f_{DANA} \end{aligned}$$

$$\frac{BW_S}{2} = \frac{1}{2} (\text{S-band sampling bandwidth})$$

$$f_{DANA} = \text{synthesizer frequency}$$

$$= \frac{f_S - 300 \text{ MHz} - \frac{BW_S}{2}}{48} \quad (1)$$

Likewise for the X-band channel:

$$f_X - f_{LO_X} = 300 \text{ MHz} + \frac{BW_X}{2}$$

$$f_X = \text{X-band downlink frequency}$$

$$f_{LO_X} = \text{X-band local oscillator frequency}$$

$$= f_X - 300 - \frac{BW_X}{2}$$

$$= 11 (16 f_{DANA} + \frac{800}{11} \text{ MHz})$$

$$\frac{BW_X}{2} = \frac{1}{2} (\text{X-band sampling bandwidth})$$

$$f_{DANA} = \frac{f_X - 1100 \text{ MHz} - \frac{BW_X}{2}}{11 \times 16}$$

or since $f_X = 11/3 f_S$ and $BW_X = 11/3 BW_S$

$$f_{DANA} = \frac{f_S - 300 - \frac{BW_S}{2}}{48} \quad (2)$$

Equation (2) is identical to (1), demonstrating that the common Dana Synthesizer oscillator can handle both S- and X-band channels. This can also be shown for the very narrow bandwidth channel.

3. **Improved phase stability.** The most significant parameter of the received signal is the information contained in its phase. To improve the accuracy of the phase data, the receiver phase instability is reduced to a minimum by enclosing the most phase-sensitive portions of the receiver (local oscillator multipliers) in a temperature-controlled assembly. Phase stability requirements are listed in Table 1.

III. Operations

Two functional types of control are required, configuration and operation.

A. Configuration Controls

To set the receiver in the required configuration, it is necessary only to select the desired operating filter bandwidths. The filter select switch is a manual control and must be selected locally. This mode of operation will be required until the MMR controller is implemented, which will occur when the VLBI channels are added and the MMR implementation is completed.

B. Operation Controls

The following operation controls are required: (1) The adjustment of the output video signal level (which is a function of the received signal strength), and (2) the programming of the local oscillator frequency to track the incoming signal.

1. **Output level adjustment.** The video output channels of the receiver are digitized on a converter with an input voltage range of ± 5 V. Under strong signal-to-noise ratios the signal output level is set to $5 (0.707) V_{rms}$ or $3.54 V_{rms}$ (+24 dBm into 50 ohms). Likewise, with a low signal-to-noise ratio, the output is essentially noise and, allowing for $5 \times$ sigma noise peaks, the output level is set at $5/5$ or $1 V_{rms}$ (+13 dBm into 50 ohms). For any ratio of signal-to-noise between these two values, the output level is set in accordance with the graph of Fig. 6. The output level adjustment is made by locally setting manually controlled IF attenuators.

2. **Local oscillator frequency programming.** The other control required to operate the OCC channels is the local oscillator frequency programming. The computer in the Radio Science Subsystem is used to program the frequency synthesizer of the local oscillator. No operator intervention at the receiver is required.

IV. Implementation

The occultation channels are being implemented in phases as required to support mission tracking requirements. Table 2 shows a summary of the implementation schedule.

Reference

1. Gregg, W. David, *Analog and Digital Communication*, John Wiley and Sons, New York, pp. 286-294.

Table 1. Occultation channels

Sampling bandwidth (BW), kHz	S-band		X-band	
	RCP	LCP	RCP	LCP
Very narrow BW	0.1	-	0.1	-
	0.5	-	0.5	-
	1.0	-	1.0	-
Narrow BW	0.82	-	3.0	-
	2.04	-	7.5	-
	4.09	-	15.0	-
	8.18	-	30.0	-
Medium BW	50	50	150	150
Phase instability, 1000 s				
Single channel	S-band X-band		< 36 deg rms < 132 deg rms	
Differential	S - 3/11 X S-band RCP-LCP X-band RCP-LCP		< 10 deg rms < 1 < 1	

Table 2. Implementation schedule

DSS	Project	Operational date S - and X-bands					
		BW - RCP channel			BW - LCP channel		
		Medium	Narrow	Very narrow	Medium	Narrow	Very narrow
63	Voyager 1 Jupiter encounter		10-78				
	Pioneer 2 Solar conjunction			7-79			
	Voyager 1 Saturn encounter	6-80			6-80		
	Galileo Faraday rotation exp					7-83	7-83
14	Voyager 2 Jupiter encounter		5-79				
	Pioneer 2 Solar conjunction			7-79			
	Galileo Faraday rotation exp	7-83			7-83	7-83	7-83
43	Voyager 2 Saturn encounter		5-81	5-81			
	Galileo Faraday rotation exp	7-83			7-83	7-83	7-83

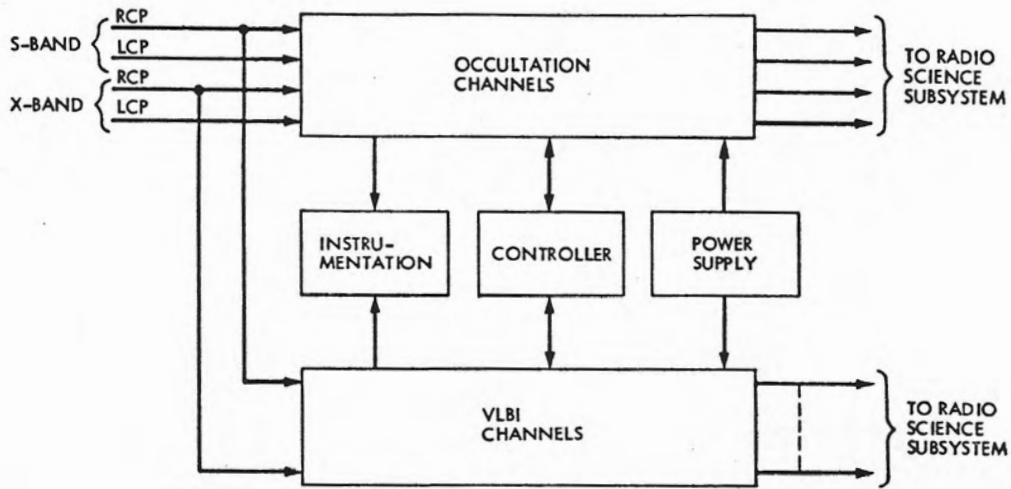

Fig. 1. Multi-Mission Receiver

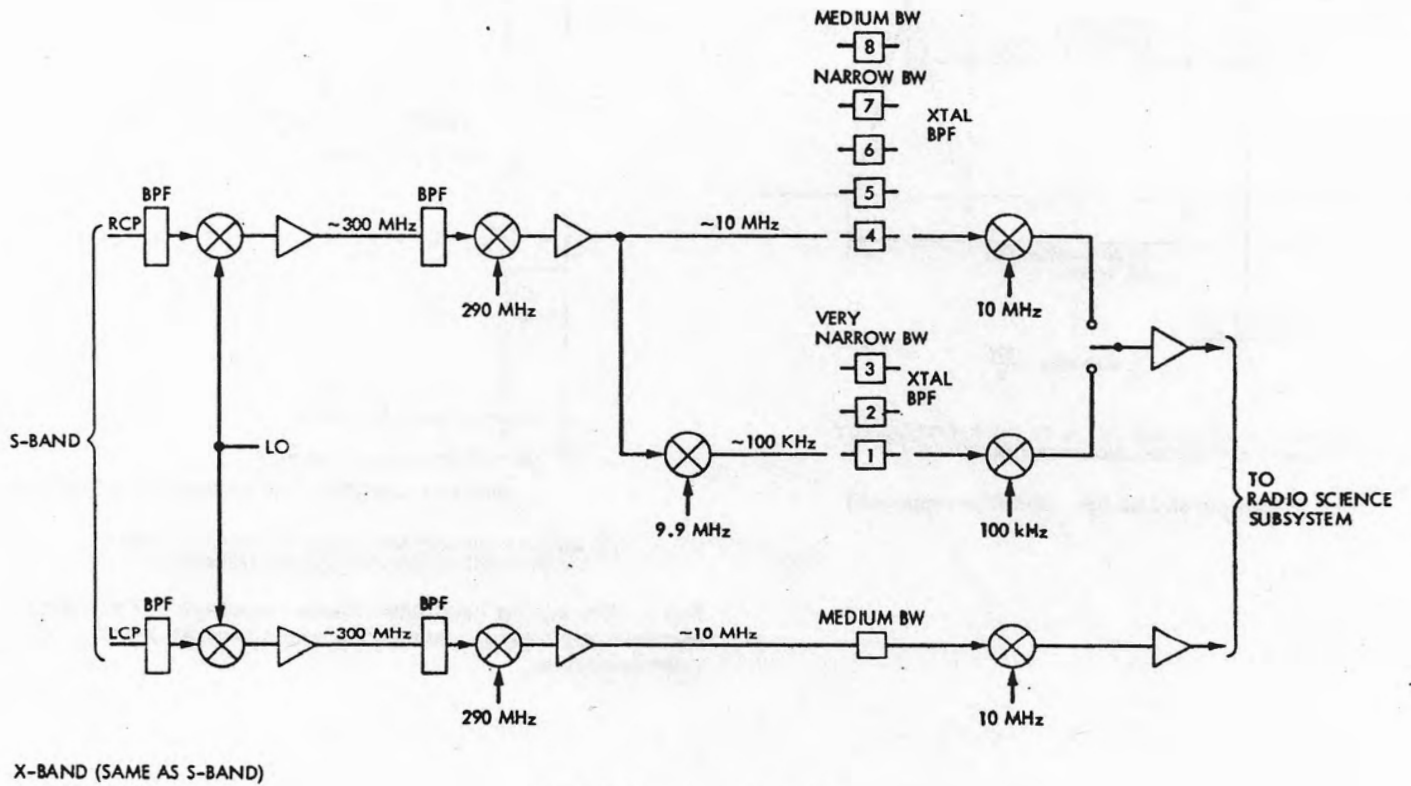
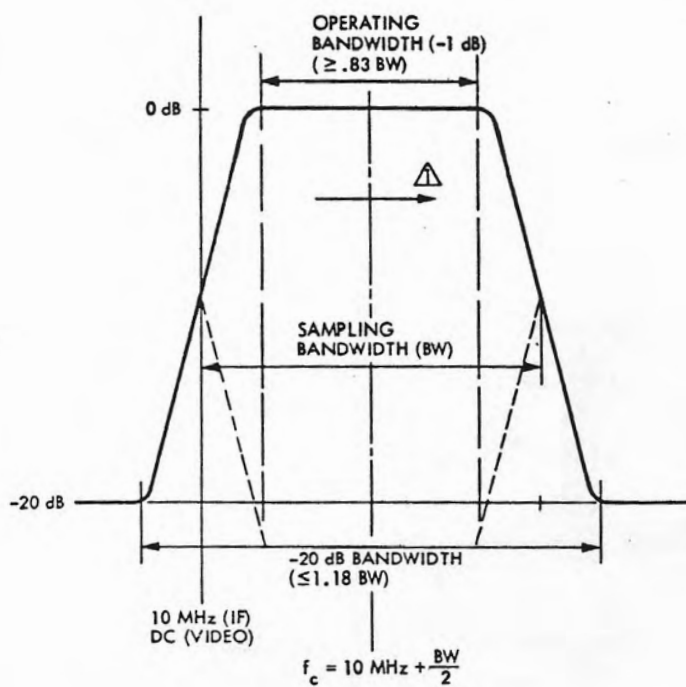

Fig. 2. Occultation channels



△ ARROW INDICATES DIRECTION OF OUTPUT FREQUENCY CHANGE WITH INCREASING INPUT FREQUENCY

Fig. 3. Medium and narrow band filter responses

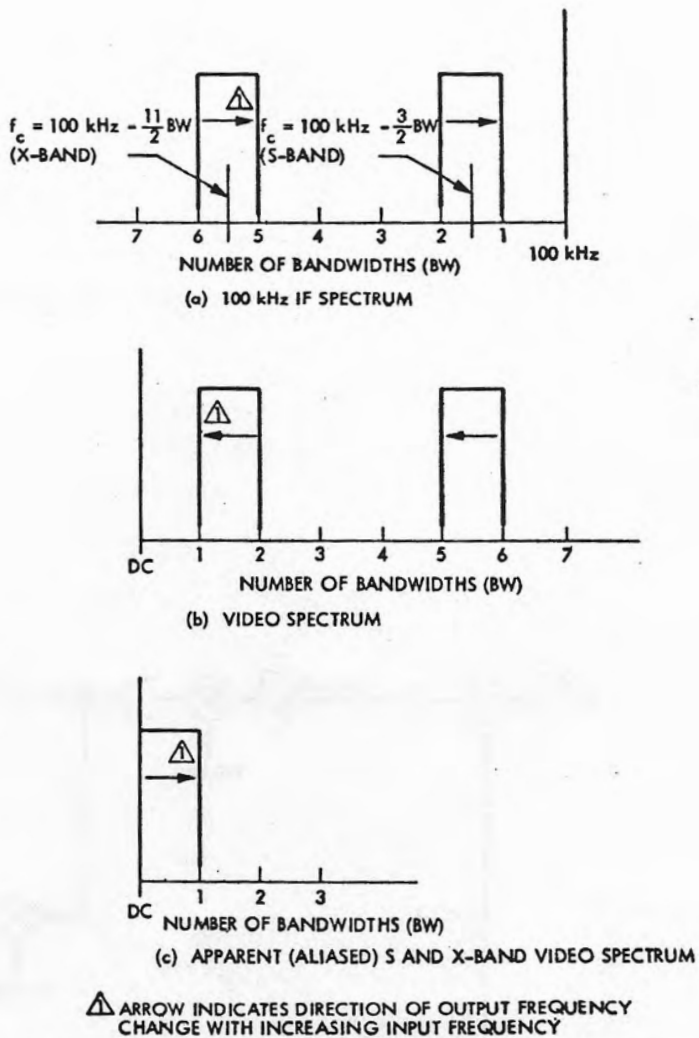

Fig. 4. Very narrow band filter channel spectrum: (a) 100-kHz IF spectrum, (b) video spectrum, (c) apparent (aliased) S- and X-band video spectrums

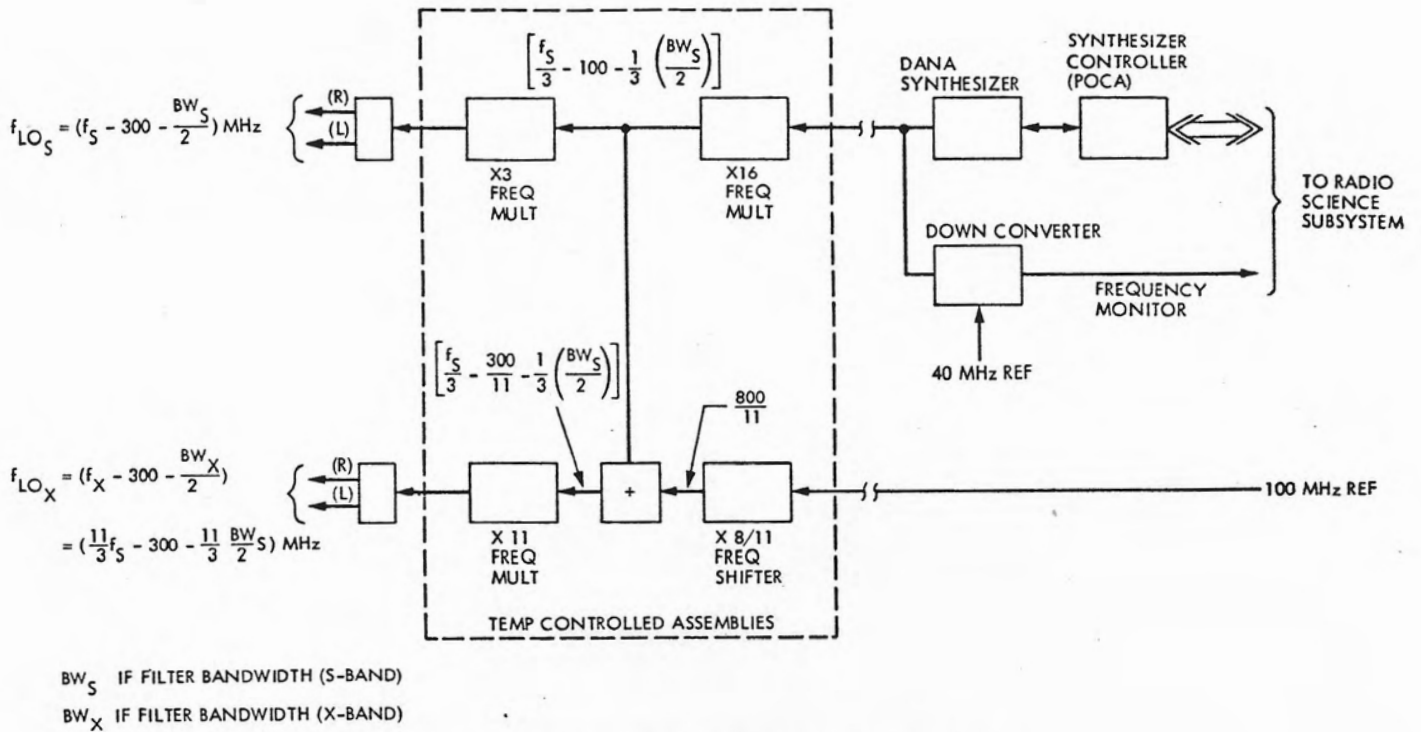

Fig. 5. Occultation channels – first local oscillator

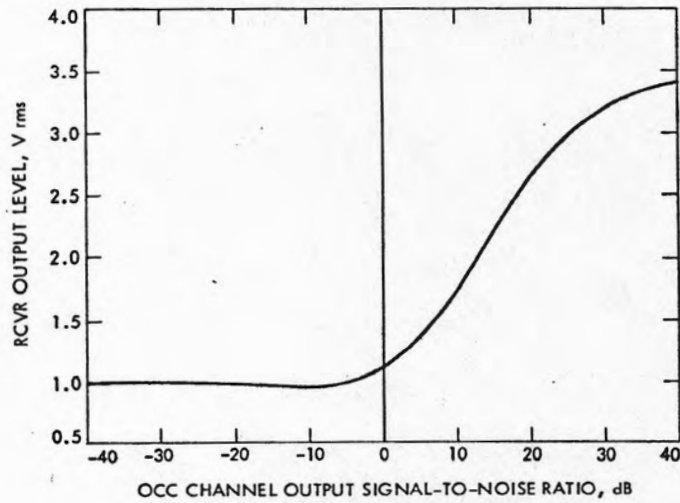

Fig. 6. OCC channel operating level